

## Model

Designation	<b>KLF6.6CNH</b>	115-127V/60Hz 1~	Sales code:	<b>106H3700</b>
-------------	------------------	------------------	-------------	-----------------

## Compressor design

Oil type	Polyolester	Refrigerant(s)	<b>R290</b>
Oil viscosity	9,7cST	Displacement	6,6cm <sup>3</sup> / 0,4cu.in
Oil quantity	170cm <sup>3</sup> / 5,7fl.oz	Compressors on pallet	100
Refr. charge - tech. limit	200g / 7,1oz		
Free gas volume comp.	1580cm <sup>3</sup> / 53,4fl.oz		
Weight	9,5kg / 20,9lbs		
Motor protection	external		
Winding resistance main	2Ω (at 25°C)		
Winding resistance aux	5,3Ω (at 25°C)		
Max. winding temp.	125°C / 257°F		
Max. discharge temp.	130°C / 266°F		



## General - Configurations with KLF6.6CNH

	<b>Conf. 1</b>	<b>Conf. 2</b>
Motorconfiguration	CSIR	RSCR
Power supply (nominal)	115-127V/60Hz	115-127V/60Hz
Number of phases	1	1
Voltage range	95-140V	95-140V
Approvals	UL, CCC	UL, CCC
Starting torque	HST	LST
Note	LRA value on compressor label and datasheet may differ due to different test conditions for UL approval.	

## Applications with KLF6.6CNH

	<b>Conf. 1</b>	<b>Conf. 2</b>
Refrigerant	R290	R290
Application	LBP+MBP	LBP+MBP
System cooling	fan 3m/s	fan 3m/s
Hot gas defrost	OK	OK
Long interval pull down	OK	OK

## Electrical data - Configurations with KLF6.6CNH

	<b>Conf. 1</b>	<b>Conf. 2</b>
Starting device type	relay	PTC
Run capacitor	-/-	15μF
Start capacitor	240μF	-/-
LRA (locked rotor amps / 4s)	27,8A	22,9A
RLA (rated load amps / 1s)	4,3A	4,3A
Cut in current	27,8A	31,5A

## Model

Designation

**KLF6.6CNH**

115-127V/60Hz 1~

Sales code:

**106H3700**

## Compressor dimensions

Housing	A Height	182mm / 7,17in
	B Height	175mm / 6,89in
	C Length shell	198mm / 7,8in
	D Length w. cover	238mm / 9,37in
	E Width	160mm / 6,3in

Connectors	Suction	Discharge	Process
	X	Y	Z
Diameter [mm]	øi 8,11-8,29	øi 6,41-6,59	øi 6,41-6,59
(i:inside, o:outside) [in]	øi 0,32-0,33	øi 0,25-0,26	øi 0,25-0,26
Material	copper	copper	copper
Horizontal angle ±2°	35°	13°	0°
Vertical angle ±2°	30°	40°	145°
Position l/h/w [mm]	120/72/62	112/106/62	-97/102/70
[in]	4,7/2,8/2,4	4,4/4,2/2,4	-3,8/4/2,8
Straight tube l. [mm]	14	14	14
[in]	0,5	0,5	0,5

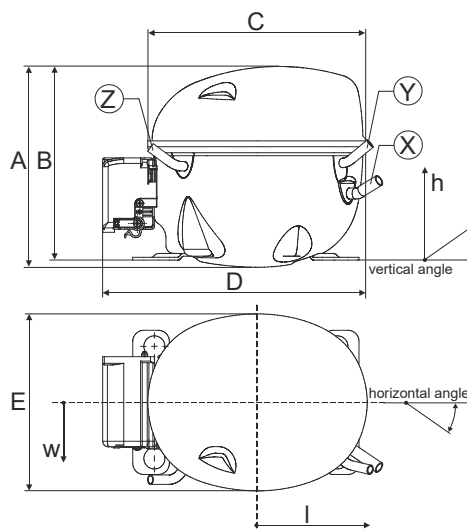

## Compressor fixation

### Bolt joint

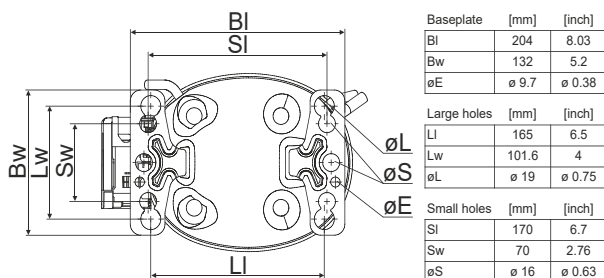

### Snap-on



## Mounting accessories

	one comp.	multi pack
Bolt joint   M6   ø16mm	118-1917	118-1918
Bolt joint   ø1/4"   ø16mm	118-1946	
Bolt joint   ø1/4"   ø19mm	118-1949	
Snap-on   ø7,3   ø16mm	118-1947	118-1919

## Application notes

Provision for PE Grounding is located at the PE Stamp on the compressor

## Model

Designation	<b>KLF6.6CNH</b>	<b>115-127V/60Hz</b>	<b>Conf. 1</b>	Sales code:	<b>106H3700</b>
-------------	------------------	----------------------	----------------	-------------	-----------------

## Configuration

Motorconfiguration	CSIR
Power supply (nominal)	115-127V/60Hz 1~
Refrigerant	R290
Application	LBP+MBP
Voltage range	95-140V
Starting torque	HST
Approvals	UL CCC

## Electrical accessories / wiring diagram

CSIR

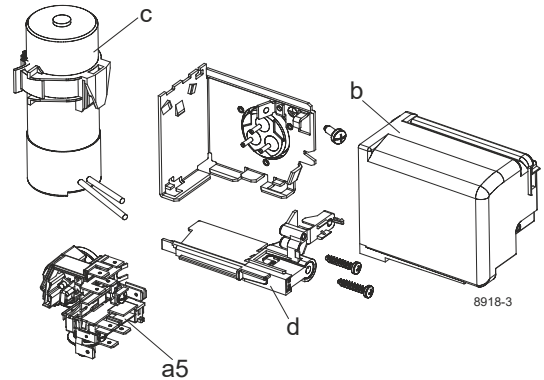

## Ambient/ machine room temperatures minimum /maximum

Ambient temperature range:	10 - 43°C / 50 - 110°F
Machine room temperature range:	10 - 48°C / 50 - 119°F
Compressor cooling:	fan 3m/s

## Operation Limits

## Operation pressure range

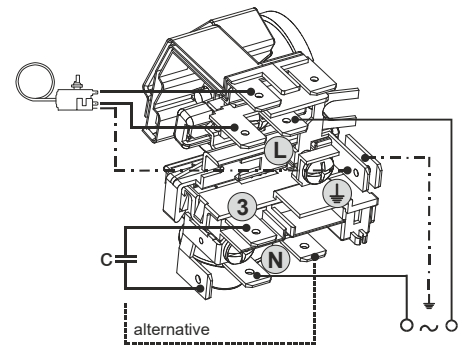
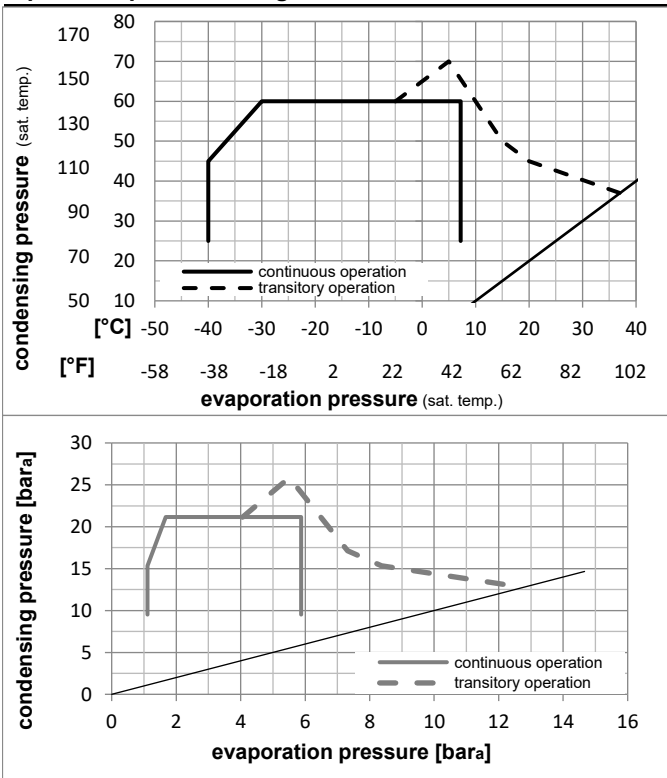

## Components

a5	current relay TY (T1141/L6-S6)	117U7076
c	start capacitor (240µF)	117U5002
b, d	cover + clamp + screws(5VA) in bag	103N1060

## Alternative components

b, d	cover + clamp + screws(5VA-compl.)	103N0600
------	------------------------------------	----------

### Model

Designation **KLF6.6CNH** **115-127V/60Hz** Conf. 1 Sales code: **106H3700**

### Optimization + standard conditions

R290, 115V/60Hz, CSIR, fan 3m/s, UL, CCC

		Evaporating pressure (saturation temperature)				Condensing pressure (saturation temperature)			Return gas temp.			Liquid temp.			Cooling capacity			COP	EER	Power consumption			
		pe	pc	RGT	Tliq	[W]	[Btu/h]	[kcal/h]	[W/W]	[Btu/Wh]	[kcal/Wh]	P1	I	Ref. mass flow	[W]	[A]	m	[kg/h]					
[°C]	[°F]																						
-23	54	32	32	396,9	1355	341,6	1,61	5,51	1,39	246,0	3,18	4,02	ASHRAE LBP										
-10	130	90	90																				
-25	55	32	55	297,2	1015	255,8	1,26	4,30	1,08	236,1	3,13	3,70	cecomaf LBP										
-13	131	90	131																				
-35	40	20	40	224,4	766	193,1	1,20	4,11	1,04	186,5	2,89	2,56	EN12900 LBP										
-31	104	68	104																				
-7	54	35	46	717,6	2451	617,6	2,08	7,09	1,79	345,8	3,84	8,19	ASHRAE MBP										
20	130	95	115																				
-10	55	32	55	567,9	1940	488,8	1,73	5,90	1,49	328,5	3,72	7,18	cecomaf MBP										
14	131	90	131																				
-10	45	20	45	639,3	2183	550,2	2,06	7,02	1,77	311,0	3,60	7,85	EN12900 MBP										
14	113	68	113																				

### Performance tables

R290, 115V/60Hz, CSIR, fan 3m/s, UL, CCC

	pe		Cooling capacity			COP	EER	P1	I	m	
	[°C]	[°F]	[W]	[Btu/h]	[kcal/h]	[W/W]	[Btu/Wh]	[kcal/Wh]	[W]	[A]	[kg/h]
[°C / °F]	-40	-40	161,8	553	139,2	0,99	3,37	0,85	163,8	2,80	1,81
cond. pressure	-34	-30	220,5	753	189,8	1,17	4,00	1,01	188,3	2,89	2,47
pc= 45/113	-23	-10	381,3	1302	328,2	1,56	5,33	1,34	244,5	3,18	4,31
return gas temp.	-15	5	546,0	1865	469,9	1,90	6,49	1,64	287,3	3,44	6,21
RGT= 32/90	-4	25	834,7	2851	718,3	2,48	8,48	2,14	336,2	3,77	9,62
liquid temp	0	32	956,4	3266	823,1	2,74	9,35	2,36	349,3	3,87	11,09
Tliq= 45/113	7,2	45	1213,8	4145	1044,6	3,32	11,34	2,86	365,7	3,99	14,26
[°C / °F]	-40	-40	139,9	478	120,4	0,92	3,14	0,79	152,3	2,74	1,73
cond. pressure	-34	-30	186,9	638	160,9	1,04	3,54	0,89	180,6	2,84	2,31
pc= 55/131	-23	-10	321,1	1097	276,3	1,30	4,45	1,12	246,4	3,19	4,00
return gas temp	-15	5	463,1	1582	398,6	1,55	5,30	1,34	298,4	3,52	5,82
RGT= 32/90	-4	25	717,9	2452	617,9	1,98	6,77	1,71	362,3	3,97	9,16
liquid temp	0	32	826,9	2824	711,6	2,17	7,40	1,87	381,3	4,11	10,62
Tliq= 55/131	7,2	45	1059,1	3617	911,5	2,58	8,83	2,22	409,7	4,33	13,80

## Model

Designation	<b>KLF6.6CNH</b>	<b>115-127V/60Hz</b>	<b>Conf. 2</b>	Sales code:	<b>106H3700</b>
-------------	------------------	----------------------	----------------	-------------	-----------------

## Configuration

Motorconfiguration	RSCR
Power supply (nominal)	115-127V/60Hz 1~
Refrigerant	R290
Application	LBP+MBP
Voltage range	95-140V
Starting torque	LST
Approvals	UL CCC

## Electrical accessories / wiring diagram

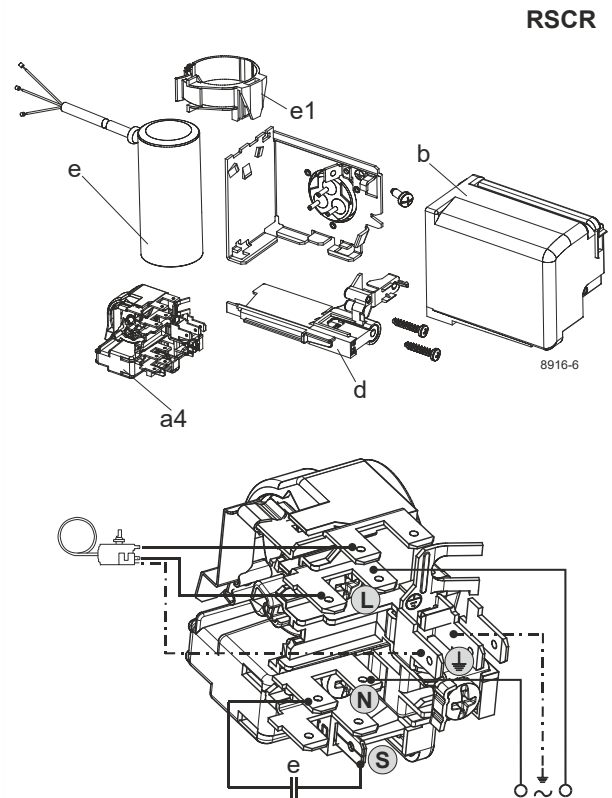

## Ambient/ machine room temperatures minimum /maximum

Ambient temperature range:	10 - 43°C / 50 - 110°F
Machine room temperature range:	10 - 48°C / 50 - 119°F
Compressor cooling:	fan 3m/s

## Operation Limits

### Operation pressure range

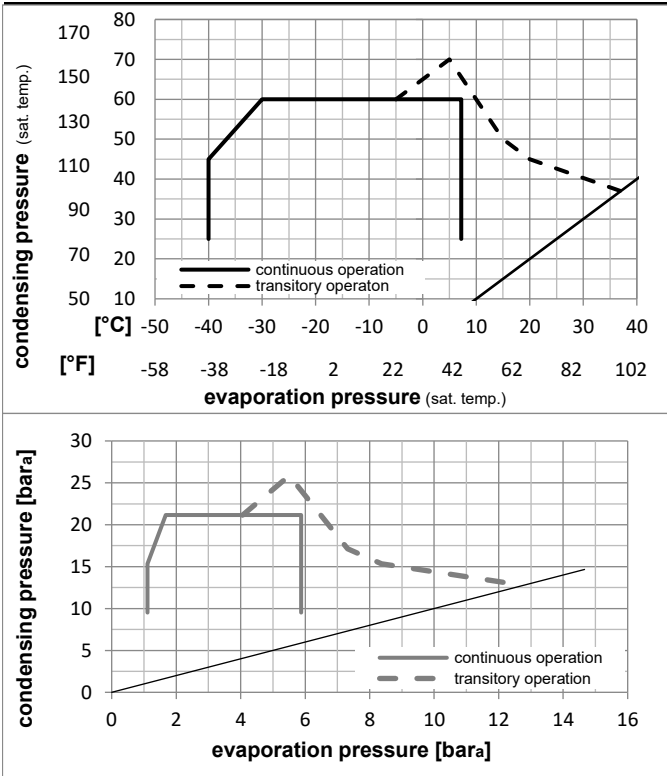

### Components

a4	DLS 6 (PTC,6.3mm, T1141/L6 - S6)	103N0214
e	run capacitor (15μF, 6,3mm)	117-7153
b, d	cover + clamp + screws(5VA) in bag	103N1060
e1	retaining clamp	103N0535

### Alternative components

b, d	cover + clamp + screws(5VA-compl.)	103N0600
------	------------------------------------	----------

### Model

Designation **KLF6.6CNH 115-127V/60Hz** Conf. 2 Sales code: **106H3700**

### Optimization + standard conditions

R290, 115V/60Hz, RSCR, fan 3m/s, UL, CCC

		Evaporating pressure (saturation temperature)				Condensing pressure (saturation temperature)						Power consumption			
		Return gas temp.		Liquid temp.		Cooling capacity		COP	EER		P1	I	Ref. mass flow		
		pe	pc	RGT	Tliq	[W]	[Btu/h]	[kcal/h]	[W/W]	[Btu/Wh]	[kcal/Wh]	[W]	[A]	[kg/h]	
[°C]	-23	54	32	32	398,4	1360	342,8	1,72	5,89	1,48	230,9	2,14	4,03	ASHRAE LBP	
[°F]	-10	130	90	90											
[°C]	-25	55	32	55	298,5	1019	256,9	1,35	4,60	1,16	221,5	2,06	3,72	cecomaf LBP	
[°F]	-13	131	90	131											
[°C]	-35	40	20	40	227,3	776	195,6	1,32	4,51	1,14	172,2	1,68	2,60	EN12900 LBP	
[°F]	-31	104	68	104											
[°C]	-7	54	35	46	716,2	2446	616,3	2,21	7,55	1,90	324,1	2,92	8,17	ASHRAE MBP	
[°F]	20	130	95	115											
[°C]	-10	55	32	55	568,4	1941	489,2	1,85	6,31	1,59	307,9	2,78	7,19	cecomaf MBP	
[°F]	14	131	90	131											
[°C]	-10	45	20	45	637,4	2177	548,5	2,23	7,62	1,92	285,8	2,59	7,83	EN12900 MBP	
[°F]	14	113	68	113											

### Performance tables

R290, 115V/60Hz, RSCR, fan 3m/s, UL, CCC

	pe		Cooling capacity			COP	EER	P1	I	m	
	[°C]	[°F]	[W]	[Btu/h]	[kcal/h]	[W/W]	[Btu/Wh]				[kcal/Wh]
[°C / °F]	-40	-40	166,6	569	143,4	1,09	3,72	0,94	153,0	1,54	1,86
cond. pressure	-34	-30	223,4	763	192,3	1,27	4,35	1,10	175,5	1,70	2,50
pc= 45/113	-23	-10	382,0	1305	328,8	1,69	5,77	1,45	226,3	2,10	4,31
return gas temp.	-15	5	545,3	1862	469,3	2,06	7,04	1,77	264,6	2,41	6,20
RGT= 32/90	-4	25	830,2	2835	714,5	2,69	9,20	2,32	308,3	2,78	9,57
liquid temp	0	32	949,7	3244	817,4	2,97	10,14	2,55	320,0	2,88	11,02
Tliq= 45/113	7,2	45	1201,1	4102	1033,7	3,59	12,25	3,09	334,8	3,01	14,11
[°C / °F]	-40	-40	139,4	476	120,0	0,98	3,33	0,84	143,0	1,45	1,72
cond. pressure	-34	-30	187,0	639	160,9	1,10	3,76	0,95	169,7	1,65	2,31
pc= 55/131	-23	-10	322,5	1102	277,6	1,40	4,76	1,20	231,2	2,14	4,02
return gas temp	-15	5	464,6	1587	399,8	1,66	5,67	1,43	279,7	2,54	5,84
RGT= 32/90	-4	25	715,9	2445	616,1	2,11	7,19	1,81	339,9	3,05	9,14
liquid temp	0	32	822,2	2808	707,6	2,30	7,84	1,98	358,1	3,21	10,56
Tliq= 55/131	7,2	45	1047,1	3576	901,1	2,71	9,26	2,33	386,1	3,45	13,64