

Model

Designation	KLF7.7CND	220-240V/50Hz 1~	Sales code:	106H2810
-------------	------------------	------------------	-------------	-----------------

Compressor design

Oil type	Polyolester	Refrigerant(s)	R290
Oil viscosity	9,7cST	Displacement	7,7cm ³ / 0,47cu.in
Oil quantity	170cm ³ / 5,7fl.oz	Compressors on pallet	100
Refr. charge - tech. limit	200g / 7,1oz		
Free gas volume comp.	1575cm ³ / 53,3fl.oz		
Weight	9,6kg / 21,2lbs		
Motor protection	external		
Winding resistance main	8,4Ω (at 25°C)		
Winding resistance aux	11,9Ω (at 25°C)		
Max. winding temp.	125°C / 257°F		
Max. discharge temp.	130°C / 266°F		



General - Configurations with KLF7.7CND

	Conf. 1
Motorconfiguration	CSIR
Power supply (nominal)	220-240V/50Hz
Number of phases	1
Voltage range	198-254V
Approvals	VDE, CCC
Starting torque	HST
Note	Electrical equipment is included and pre-assembled to compressor.

Applications with KLF7.7CND

	Conf. 1
Refrigerant	R290
Application	LBP+MBP
System cooling	fan 3m/s
Hot gas defrost	OK
Long interval pull down	OK

Electrical data - Configurations with KLF7.7CND

	Conf. 1
Starting device type	relay
Run capacitor	-/-
Start capacitor	80μF
LRA (locked rotor amps / 4s)	12,3A
RLA (rated load amps / 1s)	2,1A
Cut in current	12,3A

Model

Designation

KLF7.7CND

220-240V/50Hz 1~

Sales code:

106H2810

Compressor dimensions

Housing	A Height	182mm / 7,17in
	B Height	175mm / 6,89in
	C Length shell	198mm / 7,8in
	D Length w. cover	238mm / 9,37in
	E Width	160mm / 6,3in

Connectors	Suction	Discharge	Process
	X	Y	Z
Diameter [mm]	øi 8,11-8,29	øi 6,11-6,29	øi 6,11-6,29
(i:inside, o:outside) [in]	øi 0,32-0,33	øi 0,24-0,25	øi 0,24-0,25
Material	copper	copper	copper
Horizontal angle ±2°	35°	13°	0°
Vertical angle ±2°	30°	40°	145°
Position l/h/w [mm]	120/72/62	112/106/62	-97/102/70
[in]	4,7/2,8/2,4	4,4/4,2/2,4	-3,8/4/2,8
Straight tube l. [mm]	14	14	14
[in]	0,5	0,5	0,5

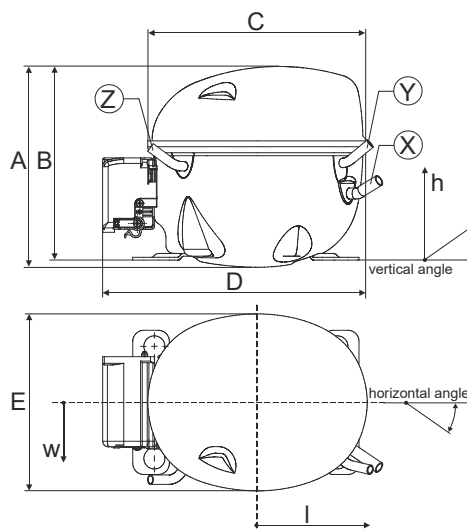

Compressor fixation

Bolt joint

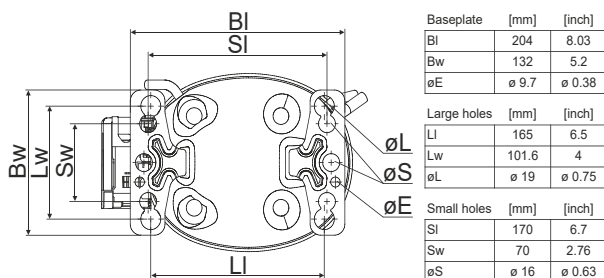

Snap-on



Mounting accessories

	one comp.	multi pack
Bolt joint M6 ø16mm	118-1917	118-1918
Bolt joint ø1/4" ø16mm	118-1946	
Bolt joint ø1/4" ø19mm	118-1949	
Snap-on ø7,3 ø16mm	118-1947	118-1919

Application notes

Operation possible until tilted up to 3 degrees

Provision for PE Grounding is located at the PE Stamp on the compressor

Model

Designation	KLF7.7CND	220-240V/50Hz	Conf. 1	Sales code:	106H2810
-------------	------------------	----------------------	----------------	-------------	-----------------

Configuration

Motorconfiguration	CSIR
Power supply (nominal)	220-240V/50Hz 1~
Refrigerant	R290
Application	LBP+MBP
Voltage range	198-254V
Starting torque	HST
Approvals	VDE CCC

Electrical accessories / wiring diagram

CSIR

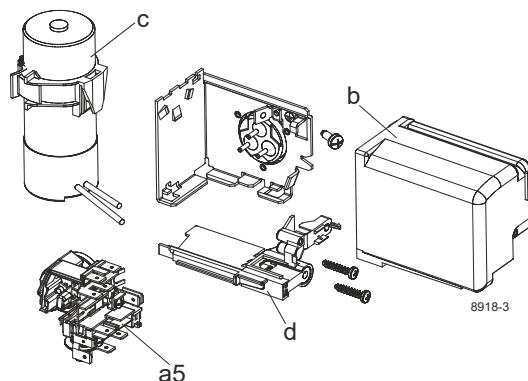

Ambient/ machine room temperatures minimum /maximum

Ambient temperature range:	10 - 43°C / 50 - 110°F
Machine room temperature range:	10 - 48°C / 50 - 119°F
Compressor cooling:	fan 3m/s

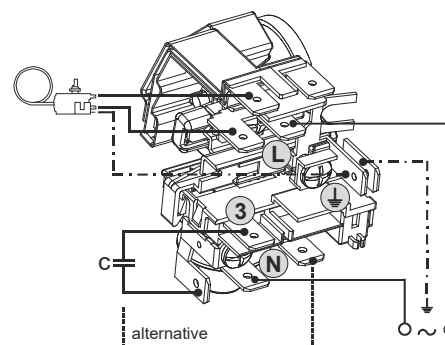

Operation Limits

Operation pressure range

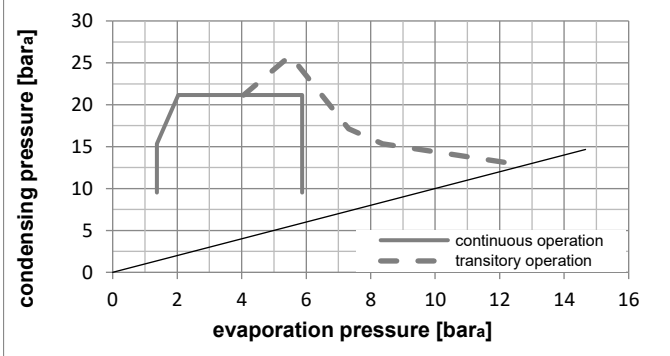
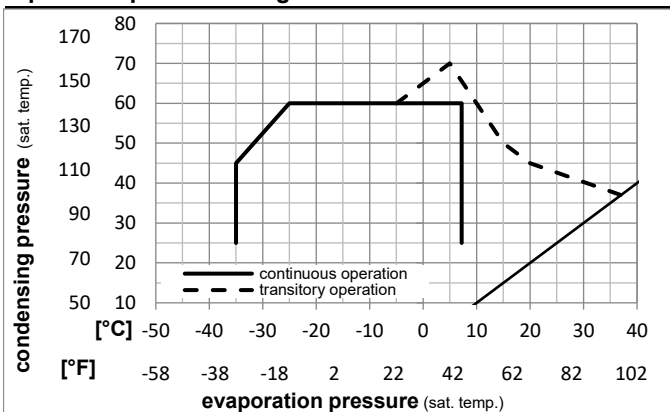

Components (already pre-assembled)

a5	current relay TY (T0377/L6-S1)	117U7071
c	start capacitor (80µF, 6.3mm)	117U5001
.	cable clamp (screws not included)	16058100
b	cover terminal board	10636401
.	screw uni en iso 4757	10641201
.	screw - uni6954	10636000

Alternative components

.	screw - uni6954	10636200
---	-----------------	----------

Model

Designation **KLF7.7CND** **220-240V/50Hz** Conf. 1 Sales code: **106H2810**

Optimization + standard conditions

R290, 220V/50Hz, CSIR, fan 3m/s, VDE, CCC

		Evaporating pressure (saturation temperature)			Condensing pressure (saturation temperature)			Return gas temp.			Liquid temp.			Cooling capacity			COP	EER	Power consumption		
		pe	pc	RGT	Tliq	[W]	[Btu/h]	[kcal/h]	[W/W]	[Btu/Wh]	[kcal/Wh]	P1	I	Ref. mass flow							
[°C]	[°F]	[°C]	[°F]	[°C]	[°F]							[W]	[A]	[kg/h]	ASHRAE LBP						
-23	54	32	32	384,5	1313	330,9	1,52	5,18	1,30	253,7	1,68	3,89	ASHRAE LBP								
-10	130	90	90												ASHRAE LBP						
-25	55	32	55	287,6	982	247,5	1,18	4,02	1,01	244,6	1,65	3,58	cecomaf LBP								
-13	131	90	131												cecomaf LBP						
-35	40	20	40	222,6	760	191,6	1,20	4,12	1,04	184,8	1,49	2,54	EN12900 LBP								
-31	104	68	104												EN12900 LBP						
-7	54	35	46	687,7	2349	591,9	2,00	6,84	1,72	343,3	1,99	7,85	ASHRAE MBP								
20	130	95	115												ASHRAE MBP						
-10	55	32	55	547,3	1869	471,0	1,67	5,71	1,44	327,5	1,93	6,92	cecomaf MBP								
14	131	90	131												cecomaf MBP						
-10	45	20	45	608,6	2079	523,8	2,03	6,93	1,75	299,9	1,83	7,47	EN12900 MBP								
14	113	68	113												EN12900 MBP						

Performance tables

R290, 220V/50Hz, CSIR, fan 3m/s, VDE, CCC

	pe		Cooling capacity			COP	EER	P1	I	m	
	[°C]	[°F]	[W]	[Btu/h]	[kcal/h]	[W/W]	[Btu/Wh]	[kcal/Wh]	[W]	[A]	[kg/h]
[°C / °F]	-35	-31	210,1	717	180,8	1,11	3,79	0,96	189,1	1,50	2,35
cond. pressure	-25	-13	342,0	1168	294,3	1,46	4,98	1,26	234,3	1,62	3,86
pc= 45/113	-15	5	523,0	1786	450,1	1,88	6,42	1,62	278,4	1,76	5,95
return gas temp.	-10	14	633,6	2164	545,3	2,11	7,22	1,82	299,9	1,83	7,25
RGT= 32/90	-5	23	758,6	2591	652,8	2,36	8,07	2,03	321,1	1,91	8,73
liquid temp	0	32	898,6	3069	773,3	2,63	8,97	2,26	342,0	1,99	10,42
Tliq= 45/113	7,2	45	1127,9	3852	970,7	3,04	10,37	2,61	371,3	2,10	13,25
[°C / °F]	-35	-31	170,7	583	146,9	0,92	3,13	0,79	186,0	1,49	2,11
cond. pressure	-25	-13	287,6	982	247,5	1,18	4,02	1,01	244,6	1,65	3,58
pc= 55/131	-15	5	448,6	1532	386,0	1,49	5,10	1,28	300,5	1,84	5,64
return gas temp	-10	14	547,3	1869	471,0	1,67	5,71	1,44	327,5	1,93	6,92
RGT= 32/90	-5	23	659,1	2251	567,2	1,86	6,36	1,60	353,6	2,03	8,40
liquid temp	0	32	784,6	2680	675,3	2,07	7,07	1,78	379,1	2,13	10,08
Tliq= 55/131	7,2	45	991,0	3385	852,9	2,39	8,17	2,06	414,5	2,27	12,91