

Model

Designation	NL8.4CLX	220-240V/50Hz 1~	Sales code:	105F3800
-------------	-----------------	------------------	-------------	-----------------

Compressor design

Oil type	Polyolester	Refrigerant(s)	R404A, R507, R452A
Oil viscosity	32cST	Displacement	8,35cm ³ / 0,51cu.in
Oil quantity	300cm ³ / 10,1fl.oz	Compressors on pallet	80
Refr. charge - tech. limit	400g / 14,1oz		
Free gas volume comp.	2310cm ³ / 78,1fl.oz		
Weight	10,4kg / 22,9lbs		
Motor protection	1# internal		
Winding resistance main	6,1Ω (at 25°C)		
Winding resistance aux	16Ω (at 25°C)		
Max. winding temp.	125°C / 257°F		
Max. discharge temp.	130°C / 266°F		



General - Configurations with NL8.4CLX

	Conf. 1	Conf. 2	Conf. 3	Conf. 4
Motorconfiguration	RSIR	CSIR	RSIR	CSIR
Power supply (nominal)	220-240V/50Hz	220-240V/50Hz	220-240V/50Hz	220-240V/50Hz
Number of phases	1	1	1	1
Voltage range	198-254V	198-254V	198-254V	198-254V
Approvals	VDE, CCC, EAC	VDE, CCC, EAC	VDE, EAC	VDE, EAC
Starting torque	LST	HST	LST	HST
Note	- / -			

Applications with NL8.4CLX

	Conf. 1	Conf. 2	Conf. 3	Conf. 4
Refrigerant	R404A	R404A	R452A	R452A
Application	LBP	LBP	LBP	LBP
System cooling	fan 3m/s	fan 3m/s	fan 3m/s	fan 3m/s
Hot gas defrost	- / -	- / -	- / -	- / -
Long interval pull down	- / -	- / -	- / -	- / -

Electrical data - Configurations with NL8.4CLX

	Conf. 1	Conf. 2	Conf. 3	Conf. 4
Starting device type	PTC	relay	PTC	relay
Run capacitor	- / -	- / -	- / -	- / -
Start capacitor	- / -	80μF	- / -	80μF
LRA (locked rotor amps / 4s)	12,1A	13,7A	12,1A	13,7A
RLA (rated load amps / 1s)	2,5A	2,5A	2,5A	2,5A
Cut in current	15,6A	13,7A	15,6A	13,7A

Model

Designation

NL8.4CLX

220-240V/50Hz 1~

Sales code:

105F3800

Compressor dimensions

Housing	A Height	203mm / 7,99in
	B Height	197mm / 7,76in
	C Length shell	205mm / 8,07in
	D Length w. cover	254mm / 10in
	E Width	166mm / 6,54in

Connectors	Suction X	Discharge Y	Process Z
Diameter [mm]	ø 8,11-8,29	ø 6,11-6,29	ø 6,11-6,29
(i:inside, o:outside) [in]	ø 0,32-0,33	ø 0,24-0,25	ø 0,24-0,25
Material	copper	copper	copper
Horizontal angle ±2°	0°	0°	0°
Vertical angle ±2°	15°	35°	155°
Position l/h/w [mm]	126/76/78	133/103/54	-107/94/72
[in]	4,9/3/3,1	5,2/4/2,1	-4,2/3,7/2,8
Straight tube l. [mm]	12	12	12
[in]	0,5	0,5	0,5

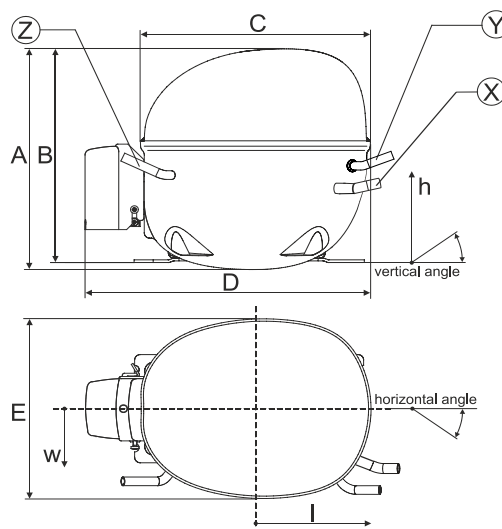

Compressor fixation

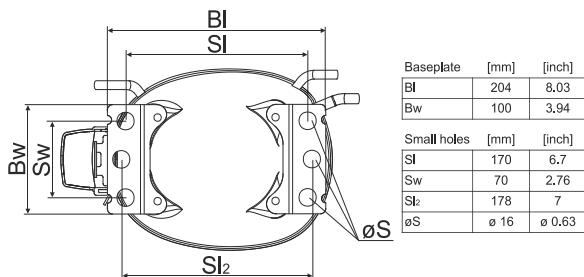

Bolt joint

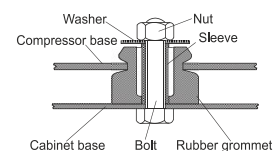

Snap-on

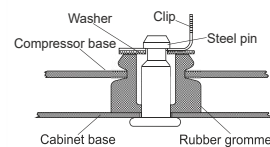

Mounting accessories

	one comp.	multi pack
Bolt joint M6 ø16mm	118-1917	118-1918
Bolt joint ø1/4" ø16mm	118-1946	
Bolt joint ø1/4" ø19mm	118-1949	
Snap-on ø7,3 ø16mm	118-1947	118-1919

Application notes

Provision for PE Grounding is located at the PE Stamp on the compressor

Model

Designation	NL8.4CLX	220-240V/50Hz	Conf. 1	Sales code:	105F3800
-------------	-----------------	----------------------	----------------	-------------	-----------------

Configuration

Motorconfiguration	RSIR
Power supply (nominal)	220-240V/50Hz 1~
Refrigerant	R404A
Application	LBP
Voltage range	198-254V
Starting torque	LST
Approvals	VDE (2)
	(1): Made in China CCC (1),(2)
	(2): Made in Slovakia EAC (1),(2)

Electrical accessories / wiring diagram

RSIR

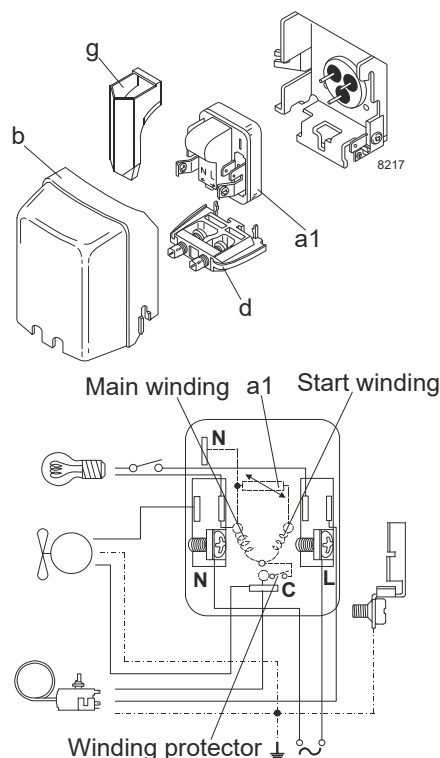

Ambient/ machine room temperatures minimum /maximum

Ambient temperature range:	10 - 38°C / 50 - 101°F
Machine room temperature range:	10 - 43°C / 50 - 110°F
Compressor cooling:	fan 3m/s

Operation Limits

Operation pressure range

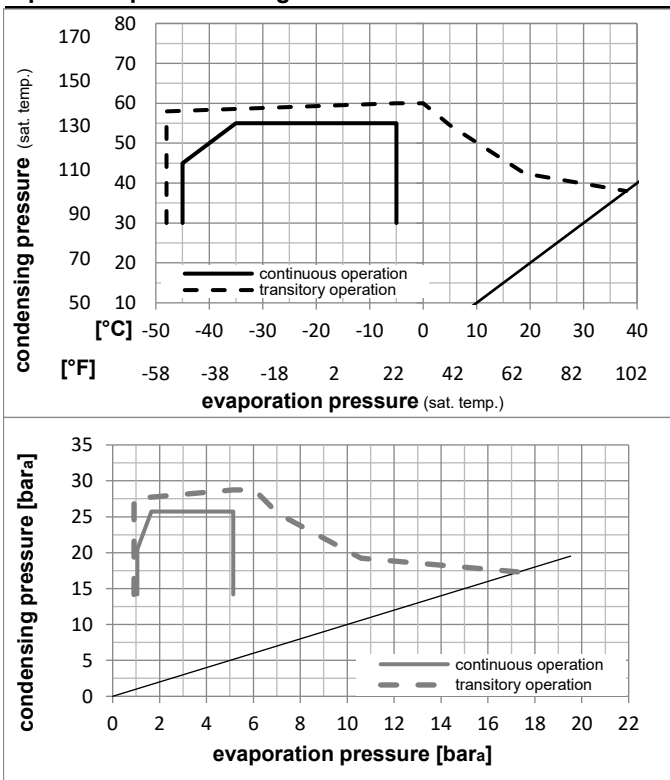

Components

a1	PTC starter (220V, 250hm, 4.8mm)	103N0018
b	plastic cover	103N2010
d	cord relief	103N1010
g	protection screen for PTC	103N0476

Alternative components

a1	PTC starter (220V, 250hm, 6.3mm)	103N0011
b	plastic cover	103N2011
d	cord relief	103N1010
g	protection screen for PTC	103N0476

Model

Designation **NL8.4CLX** **220-240V/50Hz** Conf. 1 Sales code: **105F3800**

Optimization + standard conditions

R404A, 220V/50Hz, RSIR, fan 3m/s, VDE, CCC, EAC

		Evaporating pressure (saturation temperature)				Condensing pressure (saturation temperature)			Return gas temp.			Liquid temp.			Cooling capacity			COP	EER	Power consumption			
		pe	pc	RGT	Tliq	[W]	[Btu/h]	[kcal/h]	[W/W]	[Btu/Wh]	[kcal/Wh]	P1	I	Ref. mass flow	[W]	[A]	m	[kg/h]					
[°C]	[°F]	[°C]	[°F]	[°C]	[°F]																		
-23	54	32	32	421,4	1439	362,7	1,27	4,35	1,10	330,6	2,22	9,82	ASHRAE LBP										
-10	130	90	90																				
-25	55	32	55	285,6	975	245,8	0,90	3,08	0,78	316,5	2,18	8,93	cecomaf LBP										
-13	131	90	131																				
-35	40	20	40	228,8	781	196,9	0,98	3,36	0,85	232,5	1,87	6,22	EN12900 LBP										
-31	104	68	104																				
-23	49	4,4	49	317,8	1085	273,5	0,98	3,34	0,84	325,2	2,19	11,25	ARI540 LBP										
-10	120	40	120																				
-23	41	32	32	479,0	1636	412,2	1,56	5,34	1,35	306,2	2,11	11,16	AHAM LBP										
-10	105	90	90																				
-35	45	32	45	216,4	739	186,3	0,91	3,10	0,78	238,6	1,89	5,79	opt										
-31	113	90	113																				

Performance tables

R404A, 220V/50Hz, RSIR, fan 3m/s, VDE, CCC, EAC

	pe		Cooling capacity			COP	EER	P1	I	m	
	[°C]	[°F]	[W]	[Btu/h]	[kcal/h]	[W/W]	[Btu/Wh]	[kcal/Wh]	[W]	[A]	[kg/h]
[°C / °F]	-45	-49	111,0	379	95,5	0,64	2,17	0,55	174,4	1,74	2,95
cond. pressure	-35	-31	216,4	739	186,3	0,91	3,10	0,78	238,6	1,89	5,79
pc= 45/113	-30	-22	286,5	979	246,6	1,06	3,61	0,91	271,3	1,99	7,69
return gas temp.	-25	-13	370,0	1264	318,4	1,21	4,13	1,04	305,6	2,11	9,98
RGT= 32/90	-20	-4	468,3	1599	403,0	1,37	4,67	1,18	342,6	2,25	12,70
liquid temp	-15	5	582,7	1990	501,5	1,52	5,20	1,31	383,1	2,40	15,92
Tliq= 45/113	-5	23	865,7	2957	745,0	1,81	6,18	1,56	478,6	2,76	24,07
[°C / °F]	-45	-49	75,9	259	65,4	0,48	1,63	0,41	158,8	1,71	2,33
cond. pressure	-35	-31	160,7	549	138,3	0,68	2,33	0,59	236,0	1,91	4,97
pc= 55/131	-30	-22	217,4	743	187,1	0,79	2,70	0,68	275,4	2,03	6,76
return gas temp	-25	-13	285,6	975	245,8	0,90	3,08	0,78	316,5	2,18	8,93
RGT= 32/90	-20	-4	366,6	1252	315,5	1,02	3,48	0,88	360,3	2,34	11,54
liquid temp	-15	5	461,8	1577	397,4	1,13	3,87	0,97	407,8	2,51	14,65
Tliq= 55/131	-5	23	700,2	2391	602,6	1,35	4,62	1,16	517,8	2,92	22,66

Model

Designation	NL8.4CLX	220-240V/50Hz	Conf. 2	Sales code:	105F3800
-------------	-----------------	----------------------	----------------	-------------	-----------------

Configuration

Motorconfiguration	CSIR
Power supply (nominal)	220-240V/50Hz 1~
Refrigerant	R404A
Application	LBP
Voltage range	198-254V
Starting torque	HST
Approvals	VDE (2)
	(1): Made in China CCC (1),(2)
	(2): Made in Slovakia EAC (1),(2)

Electrical accessories / wiring diagram

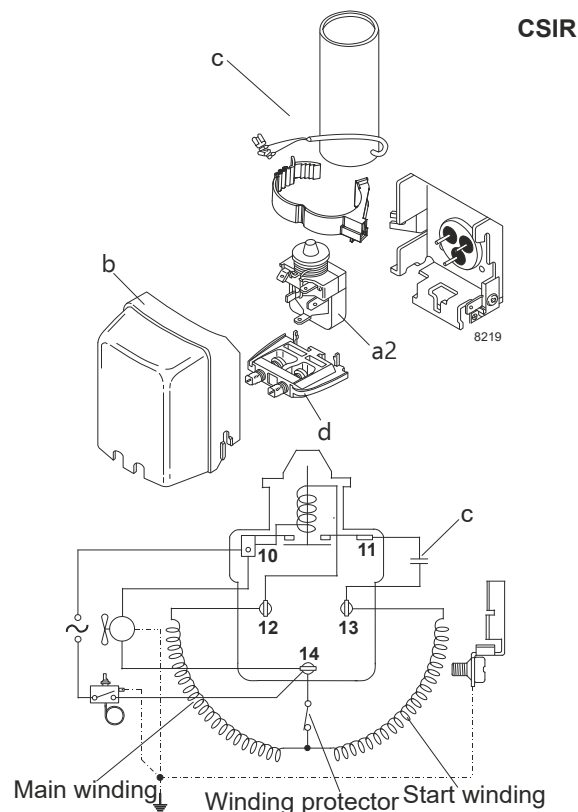

Ambient/ machine room temperatures minimum /maximum

Ambient temperature range:	10 - 38°C / 50 - 101°F
Machine room temperature range:	10 - 43°C / 50 - 110°F
Compressor cooling:	fan 3m/s

Operation Limits

Operation pressure range

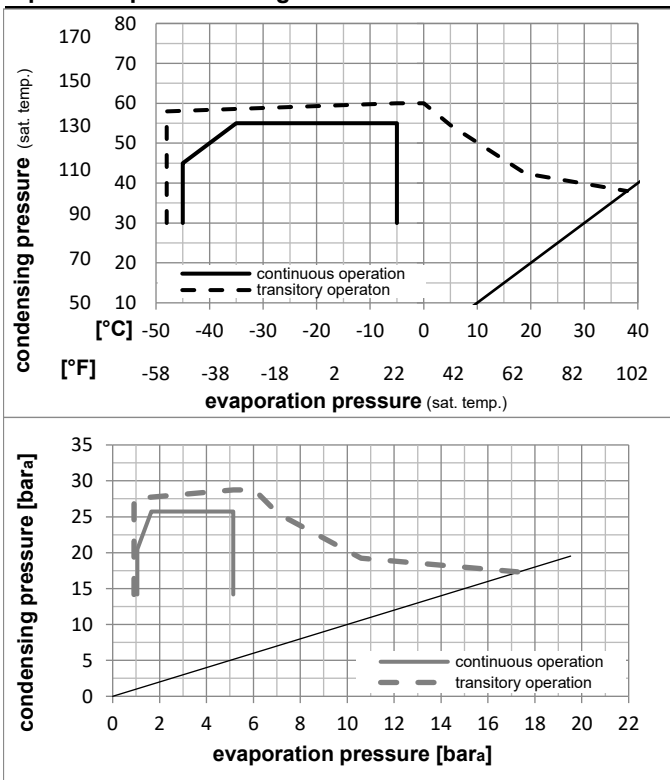

Components

a2	assy. relay	117U6003
c	start capacitor (80μF)	117U5015
b	plastic cover	103N2010
d	cord relief	103N1010

Alternative components

b	plastic cover	103N2011
---	---------------	----------

Model

Designation **NL8.4CLX** **220-240V/50Hz** Conf. 2 Sales code: **105F3800**

Optimization + standard conditions

R404A, 220V/50Hz, CSIR, fan 3m/s, VDE, CCC, EAC

	Evaporating pressure (saturation temperature)				Condensing pressure (saturation temperature)			Return gas temp.	Liquid temp.	Cooling capacity	COP	EER	Power consumption			Ref. mass flow
	pe	pc	RGT	Tliq	[W]	[Btu/h]	[kcal/h]						P1	I	m	
[°C]	[°C]	[°C]	[°C]	[W]	[Btu/h]	[kcal/h]	[W/W]	[Btu/Wh]	[kcal/Wh]	[W]	[A]	[kg/h]				
[°C]	-23	54	32	32	421,4	1439	362,7	1,27	4,35	1,10	330,6	2,22	9,82	ASHRAE LBP		
[°F]	-10	130	90	90												
[°C]	-25	55	32	55	285,6	975	245,8	0,90	3,08	0,78	316,5	2,18	8,93	cecomaf LBP		
[°F]	-13	131	90	131												
[°C]	-35	40	20	40	228,8	781	196,9	0,98	3,36	0,85	232,5	1,87	6,22	EN12900 LBP		
[°F]	-31	104	68	104												
[°C]	-23	49	4,4	49	317,8	1085	273,5	0,98	3,34	0,84	325,2	2,19	11,25	ARI540 LBP		
[°F]	-10	120	40	120												
[°C]	-23	41	32	32	479,0	1636	412,2	1,56	5,34	1,35	306,2	2,11	11,16	AHAM LBP		
[°F]	-10	105	90	90												
[°C]	-35	45	32	45	216,4	739	186,3	0,91	3,10	0,78	238,6	1,89	5,79	opt		
[°F]	-31	113	90	113												

Performance tables

R404A, 220V/50Hz, CSIR, fan 3m/s, VDE, CCC, EAC

	pe		Cooling capacity			COP	EER		P1	I	m
	[°C]	[°F]	[W]	[Btu/h]	[kcal/h]	[W/W]	[Btu/Wh]	[kcal/Wh]	[W]	[A]	[kg/h]
[°C / °F]	-45	-49	111,0	379	95,5	0,64	2,17	0,55	174,4	1,74	2,95
cond. pressure	-35	-31	216,4	739	186,3	0,91	3,10	0,78	238,6	1,89	5,79
pc= 45/113	-30	-22	286,5	979	246,6	1,06	3,61	0,91	271,3	1,99	7,69
return gas temp.	-25	-13	370,0	1264	318,4	1,21	4,13	1,04	305,6	2,11	9,98
RGT= 32/90	-20	-4	468,3	1599	403,0	1,37	4,67	1,18	342,6	2,25	12,70
liquid temp	-15	5	582,7	1990	501,5	1,52	5,20	1,31	383,1	2,40	15,92
Tliq= 45/113	-5	23	865,7	2957	745,0	1,81	6,18	1,56	478,6	2,76	24,07
[°C / °F]	-45	-49	75,9	259	65,4	0,48	1,63	0,41	158,8	1,71	2,33
cond. pressure	-35	-31	160,7	549	138,3	0,68	2,33	0,59	236,0	1,91	4,97
pc= 55/131	-30	-22	217,4	743	187,1	0,79	2,70	0,68	275,4	2,03	6,76
return gas temp	-25	-13	285,6	975	245,8	0,90	3,08	0,78	316,5	2,18	8,93
RGT= 32/90	-20	-4	366,6	1252	315,5	1,02	3,48	0,88	360,3	2,34	11,54
liquid temp	-15	5	461,8	1577	397,4	1,13	3,87	0,97	407,8	2,51	14,65
Tliq= 55/131	-5	23	700,2	2391	602,6	1,35	4,62	1,16	517,8	2,92	22,66

Model

Designation	NL8.4CLX	220-240V/50Hz	Conf. 3	Sales code:	105F3800
-------------	-----------------	----------------------	----------------	-------------	-----------------

Configuration

Motorconfiguration	RSIR
Power supply (nominal)	220-240V/50Hz 1~
Refrigerant	R452A
Application	LBP
Voltage range	198-254V
Starting torque	LST
Approvals	VDE (2)
	(1): Made in China
	EAC (1),(2)

Electrical accessories / wiring diagram

RSIR

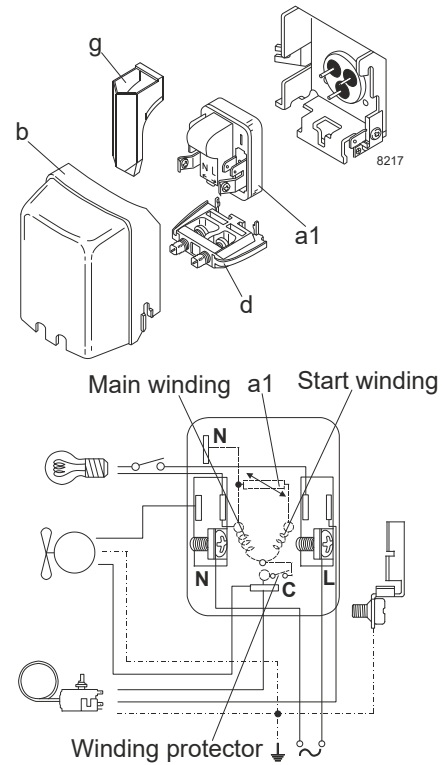

Ambient/ machine room temperatures minimum /maximum

Ambient temperature range:	10 - 38°C / 50 - 101°F
Machine room temperature range:	10 - 43°C / 50 - 110°F
Compressor cooling:	fan 3m/s

Operation Limits

Operation pressure range

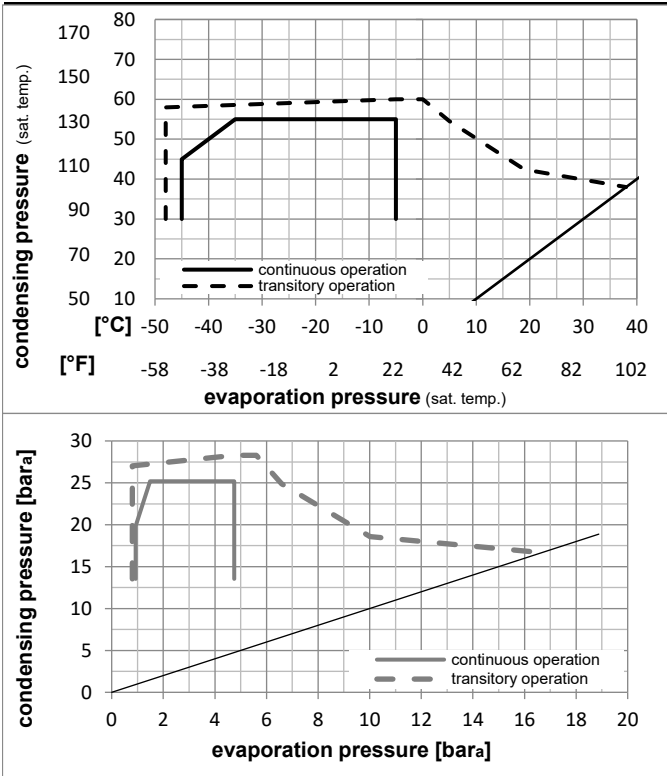

Components

a1	PTC starter (220V, 250hm, 4.8mm)	103N0018
b	plastic cover	103N2010
d	cord relief	103N1010
g	protection screen for PTC	103N0476

Alternative components

a1	PTC starter (220V, 250hm, 6.3mm)	103N0011
b	plastic cover	103N2011
d	cord relief	103N1010
g	protection screen for PTC	103N0476

Model

Designation **NL8.4CLX** **220-240V/50Hz** Conf. 3 Sales code: **105F3800**

Optimization + standard conditions

R452A, 220V/50Hz, RSIR, fan 3m/s, VDE, EAC

		Evaporating pressure (saturation temperature)				Condensing pressure (saturation temperature)						Power consumption			
		Return gas temp.		Liquid temp.		Cooling capacity		COP	EER		P1	I	Ref. mass flow		
		pe	pc	RGT	Tliq	[W]	[Btu/h]	[kcal/h]	[W/W]	[Btu/Wh]	[kcal/Wh]	[W]	[A]	[kg/h]	
[°C]	[°F]	[°C]	[°F]	[°C]	[°F]										
-23	54	32	32	384,9	1315	331,3	1,25	4,27	1,08	307,6	1,86	9,25	ASHRAE LBP		
-10	130	90	90												
-25	55	32	55	263,0	898	226,3	0,90	3,06	0,77	293,5	1,81	8,37	cecomaf LBP		
-13	131	90	131												
-35	40	20	40	206,0	704	177,3	0,96	3,29	0,83	213,7	1,60	5,75	EN12900 LBP		
-31	104	68	104												
-23	49	4,4	49	295,0	1007	253,9	0,97	3,32	0,84	303,3	1,85	10,60	ARI540 LBP		
-10	120	40	120												
-23	41	32	32	440,6	1505	379,2	1,54	5,25	1,32	286,5	1,81	10,59	AHAM LBP		
-10	105	90	90												
-35	45	32	45	194,2	663	167,2	0,89	3,04	0,77	218,5	1,62	5,33	opt		
-31	113	90	113												

Performance tables

R452A, 220V/50Hz, RSIR, fan 3m/s, VDE, EAC

	pe		Cooling capacity			COP	EER	P1			I	m
	[°C]	[°F]	[W]	[Btu/h]	[kcal/h]	[W/W]	[Btu/Wh]	[kcal/Wh]	[W]	[A]	[kg/h]	
[°C / °F]	-45	-49	94,3	322	81,2	0,61	2,08	0,52	154,7	1,50	2,58	
cond. pressure	-35	-31	194,2	663	167,2	0,89	3,04	0,77	218,5	1,62	5,33	
pc= 45/113	-30	-22	260,9	891	224,5	1,04	3,55	0,89	250,9	1,70	7,19	
return gas temp.	-25	-13	340,6	1163	293,1	1,20	4,08	1,03	284,8	1,80	9,42	
RGT= 32/90	-20	-4	434,9	1485	374,3	1,35	4,62	1,16	321,5	1,92	12,09	
liquid temp	-15	5	545,3	1862	469,3	1,51	5,15	1,30	361,6	2,06	15,26	
Tliq= 45/113	-5	23	820,6	2803	706,2	1,80	6,14	1,55	456,7	2,43	23,32	
[°C / °F]	-45	-49	62,2	212	53,5	0,45	1,55	0,39	137,2	1,48	1,95	
cond. pressure	-35	-31	143,1	489	123,2	0,67	2,29	0,58	213,8	1,60	4,51	
pc= 55/131	-30	-22	197,4	674	169,9	0,78	2,67	0,67	252,8	1,69	6,25	
return gas temp	-25	-13	263,0	898	226,3	0,90	3,06	0,77	293,5	1,81	8,37	
RGT= 32/90	-20	-4	341,3	1165	293,7	1,01	3,46	0,87	337,0	1,96	10,92	
liquid temp	-15	5	433,8	1482	373,3	1,13	3,86	0,97	384,3	2,14	13,98	
Tliq= 55/131	-5	23	667,7	2280	574,6	1,35	4,62	1,16	493,8	2,62	21,91	

Model

Designation	NL8.4CLX	220-240V/50Hz	Conf. 4	Sales code:	105F3800
-------------	-----------------	----------------------	----------------	-------------	-----------------

Configuration

Motorconfiguration	CSIR
Power supply (nominal)	220-240V/50Hz 1~
Refrigerant	R452A
Application	LBP
Voltage range	198-254V
Starting torque	HST
Approvals	VDE (2)
	(1): Made in China
	(2): Made in Slovakia

Electrical accessories / wiring diagram

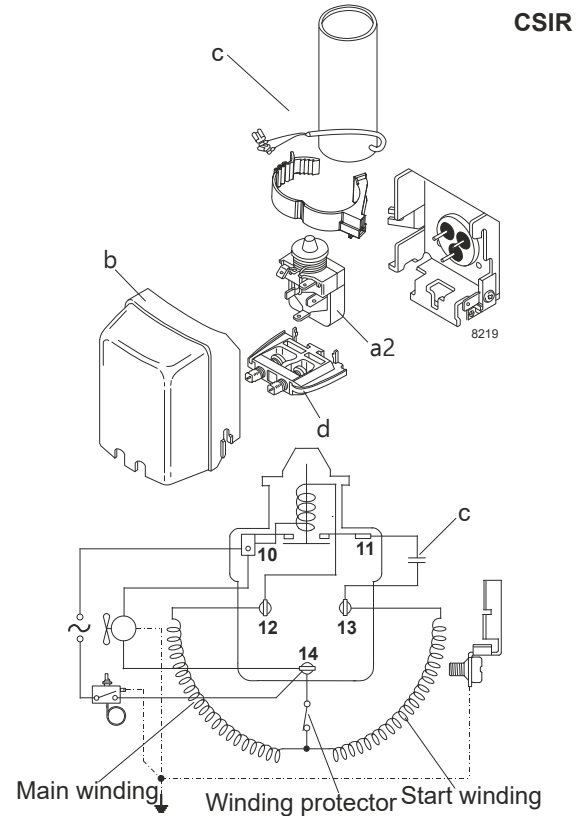

Ambient/ machine room temperatures minimum /maximum

Ambient temperature range:	10 - 38°C / 50 - 101°F
Machine room temperature range:	10 - 43°C / 50 - 110°F
Compressor cooling:	fan 3m/s

Operation Limits

Operation pressure range

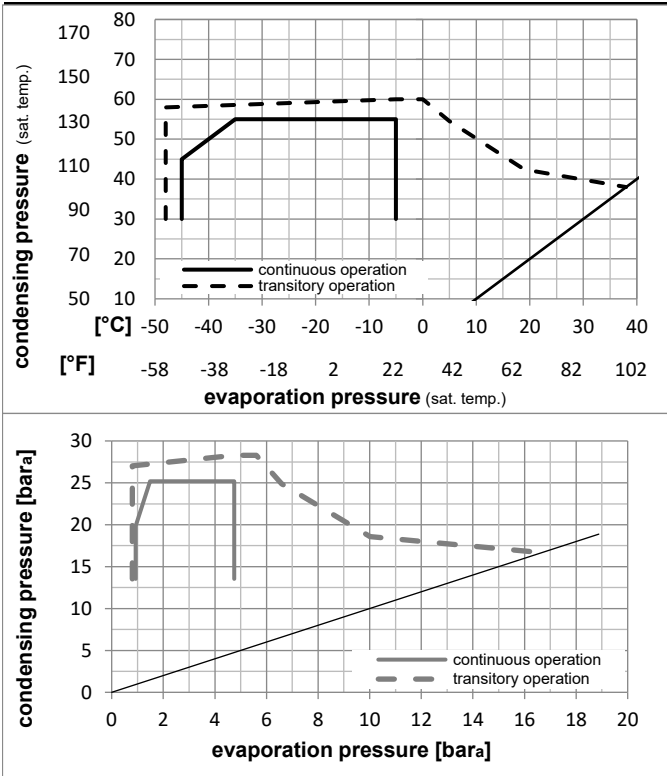

Components

a2	assy. relay	117U6003
c	start capacitor (80μF)	117U5015
b	plastic cover	103N2010
d	cord relief	103N1010

Alternative components

b	plastic cover	103N2011
---	---------------	----------

Model

Designation **NL8.4CLX** **220-240V/50Hz** Conf. 4 Sales code: **105F3800**

Optimization + standard conditions

R452A, 220V/50Hz, CSIR, fan 3m/s, VDE, EAC

		Evaporating pressure (saturation temperature)				Condensing pressure (saturation temperature)						Power consumption			
		Return gas temp.		Liquid temp.		Cooling capacity		COP	EER		P1	I	Ref. mass flow		
		pe	pc	RGT	Tliq	[W]	[Btu/h]	[kcal/h]	[W/W]	[Btu/Wh]	[kcal/Wh]	[W]	[A]	[kg/h]	
[°C]	[°F]	[°C]	[°F]	[°C]	[°F]										
-23	54	32	32	384,9	1315	331,3	1,25	4,27	1,08	307,6	1,86	9,25	ASHRAE LBP		
-10	130	90	90												
-25	55	32	55	263,0	898	226,3	0,90	3,06	0,77	293,5	1,81	8,37	cecomaf LBP		
-13	131	90	131												
-35	40	20	40	206,0	704	177,3	0,96	3,29	0,83	213,7	1,60	5,75	EN12900 LBP		
-31	104	68	104												
-23	49	4,4	49	295,0	1007	253,9	0,97	3,32	0,84	303,3	1,85	10,60	ARI540 LBP		
-10	120	40	120												
-23	41	32	32	440,6	1505	379,2	1,54	5,25	1,32	286,5	1,81	10,59	AHAM LBP		
-10	105	90	90												
-35	45	32	45	194,2	663	167,2	0,89	3,04	0,77	218,5	1,62	5,33	opt		
-31	113	90	113												

Performance tables

R452A, 220V/50Hz, CSIR, fan 3m/s, VDE, EAC

	pe		Cooling capacity			COP	EER	P1			I	m
	[°C]	[°F]	[W]	[Btu/h]	[kcal/h]	[W/W]	[Btu/Wh]	[kcal/Wh]	[W]	[A]	[kg/h]	
[°C / °F]	-45	-49	94,3	322	81,2	0,61	2,08	0,52	154,7	1,50	2,58	
cond. pressure	-35	-31	194,2	663	167,2	0,89	3,04	0,77	218,5	1,62	5,33	
pc= 45/113	-30	-22	260,9	891	224,5	1,04	3,55	0,89	250,9	1,70	7,19	
return gas temp.	-25	-13	340,6	1163	293,1	1,20	4,08	1,03	284,8	1,80	9,42	
RGT= 32/90	-20	-4	434,9	1485	374,3	1,35	4,62	1,16	321,5	1,92	12,09	
liquid temp	-15	5	545,3	1862	469,3	1,51	5,15	1,30	361,6	2,06	15,26	
Tliq= 45/113	-5	23	820,6	2803	706,2	1,80	6,14	1,55	456,7	2,43	23,32	
[°C / °F]	-45	-49	62,2	212	53,5	0,45	1,55	0,39	137,2	1,48	1,95	
cond. pressure	-35	-31	143,1	489	123,2	0,67	2,29	0,58	213,8	1,60	4,51	
pc= 55/131	-30	-22	197,4	674	169,9	0,78	2,67	0,67	252,8	1,69	6,25	
return gas temp	-25	-13	263,0	898	226,3	0,90	3,06	0,77	293,5	1,81	8,37	
RGT= 32/90	-20	-4	341,3	1165	293,7	1,01	3,46	0,87	337,0	1,96	10,92	
liquid temp	-15	5	433,8	1482	373,3	1,13	3,86	0,97	384,3	2,14	13,98	
Tliq= 55/131	-5	23	667,7	2280	574,6	1,35	4,62	1,16	493,8	2,62	21,91	