

## Model

Designation

**CU SC12CLX.2 MG\_Z 230/1/50 VAL**



Sales code:

314L4001

Engineering code:

CUSC12CLX20VE

## Application Data

Power supply	220-240V / 50Hz 1~
Refrigerants	R404A-R452A
Refr. charge - tech. limit	1300g / 45,9oz
Starter	HST / capillary tube or expansion valve
Sound pressure (10m)	37,3dB(A)

## Configuration data

	Conf. 1	Conf. 2
Voltage range	198 - 254V / 50Hz	198 - 254V / 50Hz
Refrigerant	R404A	R452A
Application	LBP	LBP

Rated performance	<u>pe=-25°C, Tsuc=20°C, Tamb=25°C, subcooling: 2K</u>	
Cooling capacity	590W / 2015Btu/h	553W / 1887Btu/h
Power consumption	479,2W	445,9W
Current consumption	3,4A	3,3A
COP/EER	1,23 / 4,21Btu/Wh	1,24 / 4,23Btu/Wh

Approvals	Eco design (EU) 2015/1095, CE, UK CA, VDE	Eco design (EU) 2015/1095, CE, UK CA, VDE
-----------	--	--

## Compressor

Designation	<b>SC12CLX.2</b>
Motor configuration	CSIR
Locked rotor amperage	23,4A
Rated load amperage	4,3A
Winding resistance main	3,4Ω
Winding resistance aux	14,4Ω
Oil quantity	500cm <sup>3</sup> / 16,9fl.oz
Oil type	POE
Horsepower rating	3/5 HP

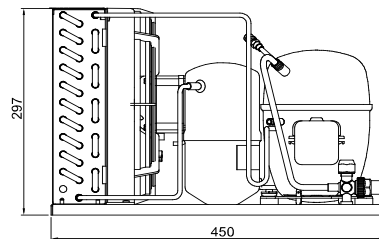

## Dimensions

### Condensing unit

Height x Width x Depth	297 x 350 x 450 [mm] / 11,7 x 13,8 x 17,7 [in]
Weight	21,8kg / 48,1lbs
Suction adapter	FLARE 1/4"
Discharge adapter	FLARE 1/4"
Process connector	ø6,2mm / 0,24in

### Package data

Height x Width x Depth	350 x 450 x 550 [mm] / 13,8 x 17,7 x 21,7 [in]
Weight	24,8kg / 54,7lbs

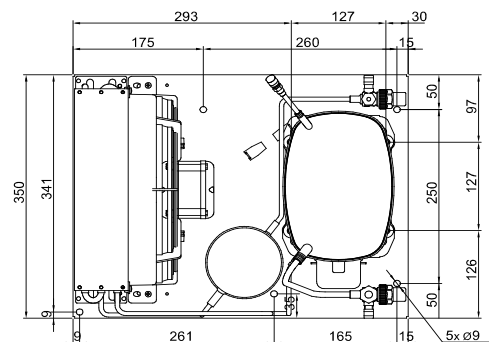

## Model

Designation **CU SC12CLX.2 MG\_Z 230/1/50 VAL**

Sales code: 314L4001  
Engineering code: CUSC12CLX20VE

## Components Condensing-Unit / Spare Parts

Component	Type	Spare part code number
Compressor code	SC12CLX.2	104L2697
Condenser	Condenser (3 rows x 11 tubes)	SP 314S0003
Fan motor	16W	MP 314S0021
Blade code	ø254mm 22°	SP 314S0026
Air flow	631,8m³/h	
Receiver code	Receiver 1,3 liter	MP 314S0036
Suction valve code	FLARE 1/4"	FLARE 1/4"
Liquid valve code	FLARE 1/4"	FLARE 1/4"

Compressor starting equipment	Spare part code number
pos. a2 - relay	117U6019
pos. c - start capacitor (80µF)	117U5017
pos. d - cord relief	103N1004
pos. b - plastic cover	103N2008

## Wiring Sketch Compressor

## Wiring Sketch Condensing Unit

CSIR

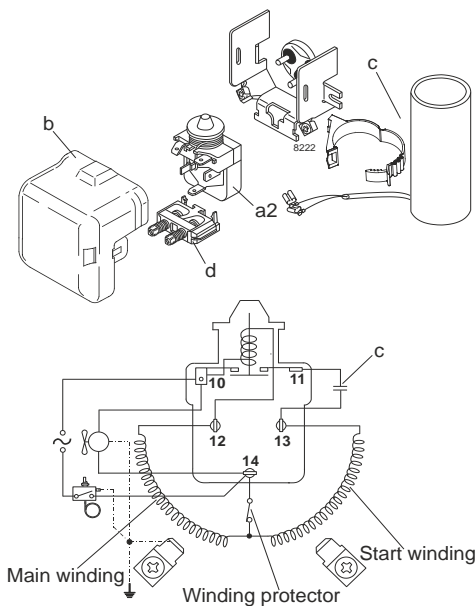

## Model

Designation **CU SC12CLX.2 MG\_Z 230/1/50 VAL**

Sales code: 314L4001

Engineering code: CUSC12CLX20VE

## Cooling performance - Conf. 1

Power supply	220-240V / 50Hz 1~	Voltage range	198 - 254V / 50Hz
Refr. charge - tech. limit	1300g / 45,9oz		
Starter	HST / capillary tube or expansion valve		
Motor configuration	CSIR		
Refrigerant	R404A		
Application	LBP		
Approvals	Eco design (EU) 2015/1095, CE, UK CA, VDE		

ambient temperature	[°C / °F]	25 / 77 (suction gas temperature [°C / °F]: 20 / 68, subcooling: 2K)						
evaporating temperature	[°C / °F]	-45 / -49	-40 / -40	-35 / -31	-30 / -22	-25 / -13	-20 / -4	-10 / 14
cooling capacity	[W]	215	290	377	478	590	714	988
COP	[W/W]	0,76	0,88	1	1,12	1,23	1,33	1,46
cooling capacity	[Btu/h]	735	990	1289	1631	2015	2437	3374
power consumption	[W]	284	329	376	425	479	538	677
current consumption	[A]	3	3	3,1	3,2	3,4	3,5	3,9

ambient temperature	[°C / °F]	32 / 90 (suction gas temperature [°C / °F]: 20 / 68, subcooling: 2K)						
evaporating temperature	[°C / °F]	-45 / -49	-40 / -40	-35 / -31	-30 / -22	-25 / -13	-20 / -4	-10 / 14
cooling capacity	[W]	175	244	324	415	516	627	873
COP	[W/W]	0,63	0,74	0,85	0,96	1,05	1,13	1,25
cooling capacity	[Btu/h]	597	832	1105	1416	1762	2141	2980
power consumption	[W]	279	328	379	433	490	553	700
current consumption	[A]	2,9	3	3,1	3,2	3,4	3,6	4

ambient temperature	[°C / °F]	38 / 100 (suction gas temperature [°C / °F]: 20 / 68, subcooling: 2K)						
evaporating temperature	[°C / °F]	-45 / -49	-40 / -40	-35 / -31	-30 / -22	-25 / -13	-20 / -4	
cooling capacity	[W]	139	203	277	359	451	551	
COP	[W/W]	0,51	0,62	0,73	0,82	0,9	0,97	
cooling capacity	[Btu/h]	476	694	944	1227	1541	1883	
power consumption	[W]	272	326	381	439	501	568	
current consumption	[A]	2,9	3	3,1	3,2	3,4	3,6	

ambient temperature	[°C / °F]	43 / 109 (suction gas temperature [°C / °F]: 20 / 68, subcooling: 2K)						
evaporating temperature	[°C / °F]	-45 / -49	-40 / -40	-35 / -31	-30 / -22	-25 / -13		
cooling capacity	[W]	109	169	237	313	396		
COP	[W/W]	0,41	0,52	0,62	0,71	0,78		
cooling capacity	[Btu/h]	373	577	808	1067	1353		
power consumption	[W]	264	322	381	443	509		
current consumption	[A]	2,8	2,9	3	3,2	3,4		

## Model

Designation **CU SC12CLX.2 MG\_Z 230/1/50 VAL**

Sales code: 314L4001

Engineering code: CUSC12CLX20VE

## Cooling performance - Conf. 2

Power supply	220-240V / 50Hz 1~	Voltage range	198 - 254V / 50Hz
Refr. charge - tech. limit	1300g / 45,9oz		
Starter	HST / capillary tube or expansion valve		
Motor configuration	CSIR		
Refrigerant	R452A		
Application	LBP		
Approvals	Eco design (EU) 2015/1095, CE, UK CA, VDE		

ambient temperature	[°C / °F]	25 / 77 (suction gas temperature [°C / °F]: 20 / 68, subcooling: 2K)						
evaporating temperature	[°C / °F]	-45 / -49	-40 / -40	-35 / -31	-30 / -22	-25 / -13	-20 / -4	-10 / 14
cooling capacity	[W]	193	263	347	443	552	674	949
COP	[W/W]	0,75	0,87	1	1,12	1,24	1,34	1,49
cooling capacity	[Btu/h]	659	899	1184	1513	1887	2302	3240
power consumption	[W]	257	301	346	394	446	503	638
current consumption	[A]	2,7	2,8	3	3,1	3,3	3,4	3,8

ambient temperature	[°C / °F]	32 / 90 (suction gas temperature [°C / °F]: 20 / 68, subcooling: 2K)						
evaporating temperature	[°C / °F]	-45 / -49	-40 / -40	-35 / -31	-30 / -22	-25 / -13	-20 / -4	-10 / 14
cooling capacity	[W]	155	220	297	385	484	594	841
COP	[W/W]	0,62	0,74	0,86	0,96	1,06	1,15	1,28
cooling capacity	[Btu/h]	528	753	1015	1315	1654	2029	2873
power consumption	[W]	250	298	347	399	455	516	659
current consumption	[A]	2,7	2,8	3	3,1	3,3	3,5	3,9

ambient temperature	[°C / °F]	38 / 100 (suction gas temperature [°C / °F]: 20 / 68, subcooling: 2K)						
evaporating temperature	[°C / °F]	-45 / -49	-40 / -40	-35 / -31	-30 / -22	-25 / -13	-20 / -4	
cooling capacity	[W]	122	183	254	334	424	524	
COP	[W/W]	0,5	0,62	0,73	0,83	0,91	0,99	
cooling capacity	[Btu/h]	418	627	868	1142	1450	1790	
power consumption	[W]	242	294	348	404	464	529	
current consumption	[A]	2,6	2,8	3	3,1	3,3	3,5	

ambient temperature	[°C / °F]	43 / 109 (suction gas temperature [°C / °F]: 20 / 68, subcooling: 2K)						
evaporating temperature	[°C / °F]	-45 / -49	-40 / -40	-35 / -31	-30 / -22	-25 / -13		
cooling capacity	[W]	95	152	218	292	374		
COP	[W/W]	0,41	0,53	0,63	0,72	0,79		
cooling capacity	[Btu/h]	326	520	743	996	1277		
power consumption	[W]	233	289	347	407	471		
current consumption	[A]	2,6	2,8	3	3,1	3,3		