

Model

Designation

CU SC18MLX.3 MG_Z 230/1/50 VAL



Sales code:

314L4015

Engineering code:

CUSC18MLX00VE

Application Data

Power supply	220-240V / 50Hz 1~
Refrigerants	R404A-R452A-R449A
Refr. charge - tech. limit	1300g / 45,9oz
Starter	HST / capillary tube or expansion valve
Sound pressure (10m)	39,7dB(A)

Configuration data

	Conf. 1	Conf. 2	Conf. 3
Voltage range	198 - 254V / 50Hz	198 - 254V / 50Hz	198 - 254V / 50Hz
Refrigerant	R404A	R452A	R449A
Application	MBP	MBP	MBP
Rated performance	<u>pe=-10°C, Tsuc=20°C, Tamb=25°C, subcooling: 2K</u>		
Cooling capacity	1622W / 5541Btu/h	1547W / 5282Btu/h	1495W / 5104Btu/h
Power consumption	869W	822,8W	775,5W
Current consumption	4,4A	4A	4,1A
COP/EER	1,87 / 6,38Btu/Wh	1,88 / 6,42Btu/Wh	1,93 / 6,58Btu/Wh
Approvals	Eco design (EU) 2015/1095, CE, UK CA, VDE	Eco design (EU) 2015/1095, CE, UK CA, VDE	Eco design (EU) 2015/1095, CE

Compressor

Designation	SC18MLX.3
Motor configuration	CSCR
Locked rotor amperage	23,4A
Rated load amperage	4,3A
Winding resistance main	3,4Ω
Winding resistance aux	14,4Ω
Oil quantity	600cm ³ / 20,3fl.oz
Oil type	POE
Horsepower rating	5/6 HP

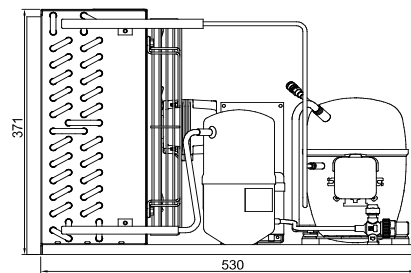

Dimensions

Condensing unit

Height x Width x Depth	371 x 430 x 530 [mm] / 14,6 x 16,9 x 20,9 [in]
Weight	28,1kg / 61,9lbs
Suction adapter	FLARE 3/8"
Discharge adapter	FLARE 1/4"
Process connector	ø6,2mm / 0,24in

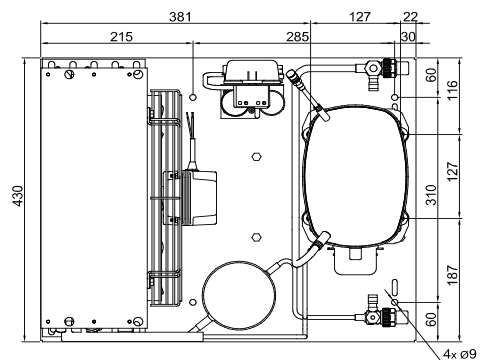

Package data

Height x Width x Depth	450 x 600 x 700 [mm] / 17,7 x 23,6 x 27,6 [in]
Weight	32,1kg / 70,7lbs

Model

Designation **CU SC18MLX.3 MG_Z 230/1/50 VAL**

Sales code: 314L4015
Engineering code: CUSC18MLX00VE

Components Condensing-Unit / Spare Parts

Component	Type	Spare part code number
Compressor code	SC18MLX.3	104L2146
Condenser	Condenser (4 rows x 14 tubes)	SP 314S0006
Fan motor	16W	MP 314S0021
Blade code	ø300mm 19°	SP 314S0028
Air flow	838m³/h	
Receiver code	Receiver 1,3 liter	MP 314S0036
Suction valve code	FLARE 3/8"	FLARE 3/8"
Liquid valve code	FLARE 1/4"	FLARE 1/4"

Compressor starting equipment	Spare part code number
pos. a3 - SC starter kit (550mm)	117-7027
pos. b - plastic cover	103N2009
pos. d - cord relief	103N1004

Wiring Sketch Compressor

Wiring Sketch Condensing Unit

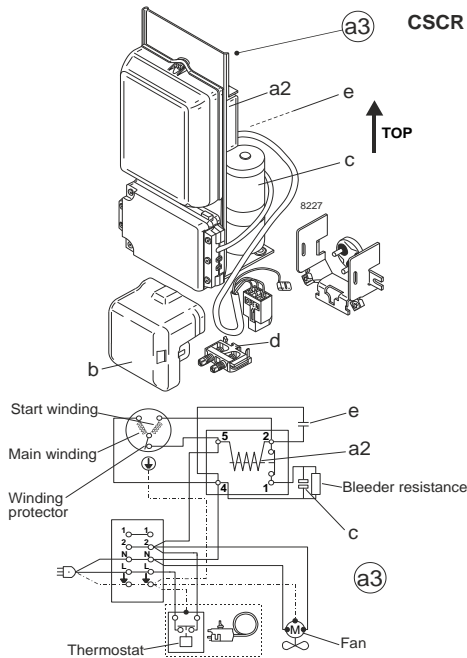

Model

Designation **CU SC18MLX.3 MG_Z 230/1/50 VAL**

Sales code: 314L4015

Engineering code: CUSC18MLX00VE

Cooling performance - Conf. 1

Power supply	220-240V / 50Hz 1~	Voltage range	198 - 254V / 50Hz
Refr. charge - tech. limit	1300g / 45,9oz		
Starter	HST / capillary tube or expansion valve		
Motor configuration	CSCR		
Refrigerant	R404A		
Application	MBP		
Approvals	Eco design (EU) 2015/1095, CE, UK CA, VDE		

ambient temperature	[°C / °F]	25 / 77 (suction gas temperature [°C / °F]: 20 / 68, subcooling: 2K)						
evaporating temperature	[°C / °F]	-25 / -13	-20 / -4	-15 / 5	-10 / 14	0 / 32	5 / 41	10 / 50
cooling capacity	[W]	938	1141	1370	1622	2186	2489	2799
COP	[W/W]	1,46	1,6	1,74	1,87	2,09	2,17	2,22
cooling capacity	[Btu/h]	3205	3896	4678	5541	7466	8502	9559
power consumption	[W]	642	714	789	869	1047	1149	1261
current consumption	[A]	3,7	3,9	4,1	4,4	5	5,3	5,6

ambient temperature	[°C / °F]	32 / 90 (suction gas temperature [°C / °F]: 20 / 68, subcooling: 2K)						
evaporating temperature	[°C / °F]	-25 / -13	-20 / -4	-15 / 5	-10 / 14	0 / 32	5 / 41	
cooling capacity	[W]	838	1019	1223	1446	1942	2206	
COP	[W/W]	1,27	1,38	1,49	1,59	1,75	1,81	
cooling capacity	[Btu/h]	2861	3481	4175	4938	6632	7533	
power consumption	[W]	659	737	820	909	1109	1222	
current consumption	[A]	3,8	4	4,3	4,5	5,1	5,4	

ambient temperature	[°C / °F]	38 / 100 (suction gas temperature [°C / °F]: 20 / 68, subcooling: 2K)			
evaporating temperature	[°C / °F]	-25 / -13	-20 / -4	-15 / 5	-10 / 14
cooling capacity	[W]	751	913	1093	1290
COP	[W/W]	1,11	1,2	1,28	1,36
cooling capacity	[Btu/h]	2565	3117	3732	4404
power consumption	[W]	677	761	852	949
current consumption	[A]	3,9	4,1	4,3	4,5

ambient temperature	[°C / °F]	43 / 109 (suction gas temperature [°C / °F]: 20 / 68, subcooling: 2K)	
evaporating temperature	[°C / °F]	-25 / -13	-20 / -4
cooling capacity	[W]	680	823
COP	[W/W]	0,98	1,05
cooling capacity	[Btu/h]	2321	2811
power consumption	[W]	694	785
current consumption	[A]	3,8	4

Model

Designation **CU SC18MLX.3 MG_Z 230/1/50 VAL**

Sales code: 314L4015

Engineering code: CUSC18MLX00VE

Cooling performance - Conf. 2

Power supply	220-240V / 50Hz 1~	Voltage range	198 - 254V / 50Hz
Refr. charge - tech. limit	1300g / 45,9oz		
Starter	HST / capillary tube or expansion valve		
Motor configuration	CSCR		
Refrigerant	R452A		
Application	MBP		
Approvals	Eco design (EU) 2015/1095, CE, UK CA, VDE		

ambient temperature	[°C / °F]	25 / 77 (suction gas temperature [°C / °F]: 20 / 68, subcooling: 2K)						
evaporating temperature	[°C / °F]	-25 / -13	-20 / -4	-15 / 5	-10 / 14	0 / 32	5 / 41	10 / 50
cooling capacity	[W]	873	1071	1296	1546	2113	2421	2739
COP	[W/W]	1,45	1,6	1,74	1,88	2,12	2,2	2,25
cooling capacity	[Btu/h]	2981	3657	4425	5281	7218	8267	9354
power consumption	[W]	602	671	745	823	999	1102	1216
current consumption	[A]	3	3,4	3,7	4	4,7	5,2	5,7

ambient temperature	[°C / °F]	32 / 90 (suction gas temperature [°C / °F]: 20 / 68, subcooling: 2K)						
evaporating temperature	[°C / °F]	-25 / -13	-20 / -4	-15 / 5	-10 / 14	0 / 32	5 / 41	
cooling capacity	[W]	780	958	1160	1383	1886	2157	
COP	[W/W]	1,27	1,39	1,5	1,61	1,78	1,84	
cooling capacity	[Btu/h]	2664	3272	3962	4724	6440	7367	
power consumption	[W]	615	691	773	860	1058	1173	
current consumption	[A]	3,1	3,4	3,8	4,1	5	5,5	

ambient temperature	[°C / °F]	38 / 100 (suction gas temperature [°C / °F]: 20 / 68, subcooling: 2K)			
evaporating temperature	[°C / °F]	-25 / -13	-20 / -4	-15 / 5	-10 / 14
cooling capacity	[W]	700	859	1039	1238
COP	[W/W]	1,11	1,21	1,3	1,38
cooling capacity	[Btu/h]	2389	2934	3549	4227
power consumption	[W]	629	712	801	897
current consumption	[A]	3,2	3,5	3,8	4,2

ambient temperature	[°C / °F]	43 / 109 (suction gas temperature [°C / °F]: 20 / 68, subcooling: 2K)		
evaporating temperature	[°C / °F]	-25 / -13	-20 / -4	-15 / 5
cooling capacity	[W]	633	777	937
COP	[W/W]	0,98	1,06	1,13
cooling capacity	[Btu/h]	2163	2652	3200
power consumption	[W]	644	732	828
current consumption	[A]	3,2	3,5	3,9

Model

Designation **CU SC18MLX.3 MG_Z 230/1/50 VAL**

Sales code: 314L4015

Engineering code: CUSC18MLX00VE

Cooling performance - Conf. 3

Power supply	220-240V / 50Hz 1~	Voltage range	198 - 254V / 50Hz
Refr. charge - tech. limit	1300g / 45,9oz		
Starter	HST / capillary tube or expansion valve		
Motor configuration	CSCR		
Refrigerant	R449A		
Application	MBP		
Approvals	Eco design (EU) 2015/1095, CE		

ambient temperature	[°C / °F]	25 / 77 (suction gas temperature [°C / °F]: 20 / 68, subcooling: 2K)						
evaporating temperature	[°C / °F]	-15 / 5	-10 / 14	-6,7 / 20	-5 / 23	0 / 32	5 / 41	10 / 50
cooling capacity	[W]	1239	1494	1679	1778	2087	2421	2773
COP	[W/W]	1,77	1,93	2,03	2,07	2,2	2,31	2,39
cooling capacity	[Btu/h]	4231	5103	5733	6072	7128	8267	9469
power consumption	[W]	700	776	829	857	947	1047	1160
current consumption	[A]	3,9	4,1	4,2	4,3	4,6	4,8	5,2

ambient temperature	[°C / °F]	32 / 90 (suction gas temperature [°C / °F]: 20 / 68, subcooling: 2K)						
evaporating temperature	[°C / °F]	-15 / 5	-10 / 14	-6,7 / 20	-5 / 23	0 / 32	5 / 41	
cooling capacity	[W]	1123	1354	1521	1611	1891	2192	
COP	[W/W]	1,54	1,67	1,75	1,78	1,88	1,96	
cooling capacity	[Btu/h]	3835	4624	5195	5503	6457	7485	
power consumption	[W]	727	812	871	903	1005	1117	
current consumption	[A]	3,9	4,2	4,3	4,4	4,7	5	

ambient temperature	[°C / °F]	38 / 100 (suction gas temperature [°C / °F]: 20 / 68, subcooling: 2K)			
evaporating temperature	[°C / °F]	-15 / 5	-10 / 14	-6,7 / 20	-5 / 23
cooling capacity	[W]	1019	1229	1381	1462
COP	[W/W]	1,35	1,45	1,51	1,54
cooling capacity	[Btu/h]	3482	4198	4715	4994
power consumption	[W]	755	847	913	948
current consumption	[A]	4	4,3	4,5	4,6

ambient temperature	[°C / °F]	43 / 109 (suction gas temperature [°C / °F]: 20 / 68, subcooling: 2K)
evaporating temperature	[°C / °F]	-15 / 5
cooling capacity	[W]	932
COP	[W/W]	1,19
cooling capacity	[Btu/h]	3184
power consumption	[W]	781
current consumption	[A]	4,1