

# Instructions

## Electronic Unit for BD1.4F-AUTO Compressor, 101N1010, 12V DC

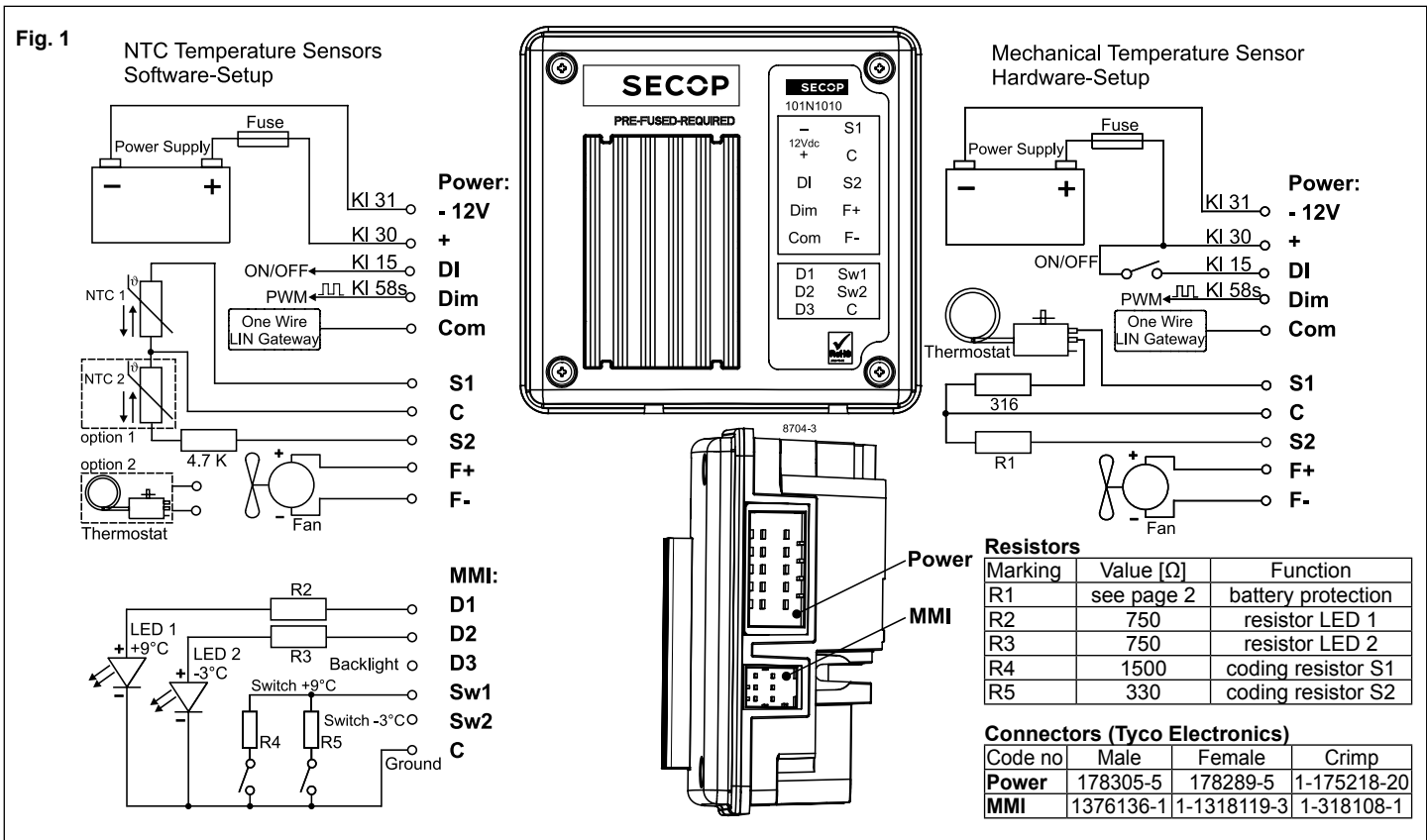

### ENGLISH

The electronic unit is a single voltage device. This means that the unit can only be used with 12V DC power supply systems. Maximum voltage is 17V DC, max. ambient temperature is 55°C. The electronic unit has a built-in thermal protection which is actuated and stops the compressor operation if the electronic unit temperature becomes too high (100°C/212°F on the PCB). It can be connected to a PC through the *Secop One Wire/LIN Gateway* communication interface on the terminal Com and - (Fig. 6). Communication gateway modules incl. communication cables can be ordered at Secop.

The PC interface allows you to create different settings and reads out several measurements by using the software tool TOOL4COOL® supplied by Secop.

#### Installation (Fig. 3)

Mount the electronic unit directly on the compressor plug and fix it with screws.

#### Power supply (Fig. 1)

The electronic unit must always be connected directly to the battery poles. Connect the plus to + and the minus to -, otherwise the electronic unit will not work. The electronic unit is protected against reverse battery connection. For protection during installation, a fuse must be mounted in the + cable as close to the battery as possible. It is recommended to use 12A fuses for 12V circuits. When a main switch is connected it must be connected on the terminals DI and +. When there is no main switch DI must be short circuit with +. The wire dimensions in Fig. 4 must be observed. Avoid extra junctions in the power supply system to prevent voltage drop from affecting the battery protection setting.

#### Battery protection (Fig. 2)

The compressor stops and restarts again according to the designated voltage limits measured on the + and - terminals of the electronic unit. The standard settings for the power supply systems are shown in Fig. 2a. Other settings are set through the communication interface (Fig. 2b). When using a mechanical thermostat battery cut in and cut out values can be set via a resistor on the terminals S2 and C.

#### Thermostat (Fig. 1)

The thermostat is connected between the terminals C and S1. Either a NTC (electrical thermostat) or a mechanical thermostat can be connected.

When using the NTC function it is necessary to mount another NTC in series with a 4,7kΩ resistor on the terminals C and S2. This NTC sensor will then obtain the ambient temperature and switch off the compressor in case of ambient higher than 55°C. Three different thermostat modes can be chosen in the software - *Auto* (both NTC and mechanical), *NTC* or *Mechanical*. Standard setting is *Auto*. When *Auto* is set and a mechanical thermostat is used it is necessary to mount a 316Ω resistor on the terminals C and S1.

In case of using a NTC the set point in the range between -40° C and 40° C is set with the software and the temperature can also be seen by using the interface. When using the *Auto* setting in the software this not possible to obtain NTC failures, so it is recommended to set the thermostat mode to *NTC* when using a NTC.

#### Speed selection (Fig. 1)

The compressor will run with a fixed speed of 3,000 rpm when the thermostat is switched on. A start delay in the range from 2-240 sec. (factory setting 4 sec.) after thermostat cut-in can also be chosen.

By default the compressor will start with a speed of 2,500 rpm for the first 30 sec.

#### Fan (Fig. 1)

A fan can be connected between the terminals F+ and F-. Connect the plus to F+ and the minus to F-. Since the output voltage between the terminals + and F is always regulated to 12V, a 12V fan must be used. The fan output can supply a continuous current of 0.65A<sub>avg</sub>. A higher current draw is allowed for 2 seconds during start.

The factory setting is no fans. If fans are used without adapting the software settings, the fans will run but no error signal will be sent in case of fan failure.

It is also possible to set a start delay on the fans in the range from 0-240 sec. Factory settings for the fan is 0 sec. Fan speed is fixed

#### Error handling (Fig. 5)

If the electronic unit records an operational error, the error can be read out in the software.

#### MMI (Fig. 1)

It is possible to connect 2 switches and 2 LED's to the controller. With each switch a set point for the thermostat can be selected or deselected and the LEDs show the chosen set point.

Default setting for the set points is +9° C *fridge set point* and -3° C *freezer set point*. Other set point values can be established via TOOL4COOL®. The switches are connected to the terminals SW1 and C. The switch for choosing the *fridge set point* shall be mounted in series with a 1500Ω resistor.

The switch for choosing the *freezer set point* shall be mounted in series with a 330Ω resistor. The LED for indicating the *fridge set point* shall be mounted on the terminals D1 and C in series with 750Ω resistors.

The LED for indicating the *freezer set point* shall be mounted on the terminals D2 and C in series with 750Ω resistors.

The intensity of the LED's can be controlled via a pwm 100kHz - 10kHz to the terminal DIM.

# Instructions

## Electronic Unit for BD1.4F-AUTO Compressor, 101N1010, 12V DC

Fig. 2a

**Standard battery protection settings**

12V cut-out [V]	12V cut-in [V]
8.5	9.0

Fig. 2b

**Optional battery protections settings (calculated)**

Resistor (R1)	12V cut-out	12V cut-in	12V max.
[kΩ]	[V]	[V]	Voltage [V]
0	9.60	10.90	17.0
0.17	9.73	11.03	17.0
0.34	9.86	11.16	17.0
0.54	10.00	11.30	17.0
0.75	10.12	11.42	17.0
0.97	10.25	11.55	17.0
1.23	10.38	11.68	17.0
1.50	10.52	11.82	17.0
1.81	10.65	11.95	17.0
2.15	10.78	12.08	17.0
2.53	10.91	12.21	17.0
2.96	11.04	12.34	17.0
3.44	11.17	12.47	17.0
3.99	11.30	12.60	17.0

Fig. 3

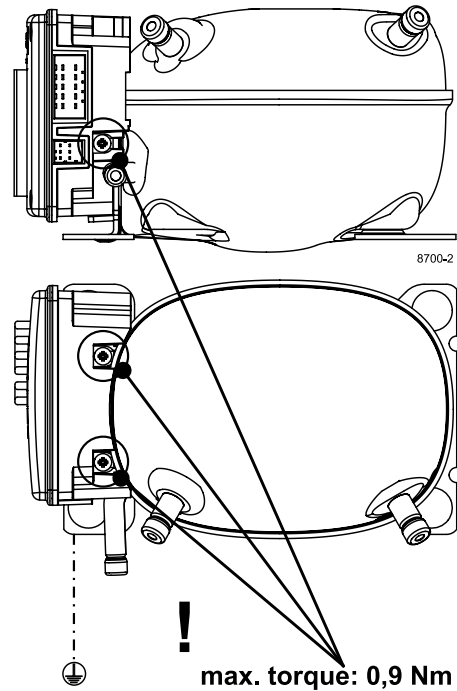

Fig. 4

**Wire Dimensions DC**

Cross section	Size		Max. length* 12V operation	
	[mm²]	AWG [Gauge]	[m]	[ft.]
2.5	12	2.5	8	
4	12	4	13	
6	10	6	20	
10	8	10	33	

\*Length between battery and electronic unit

Fig. 5

**Operational errors**

Error code	Error type
	Can be read out in the software TOOL4COOL®
7	<b>Communication failure</b>
6	<b>Thermostat failure</b> (If the NTC thermistor is short-circuit or has no connection, the electronic unit will enter manual mode).
5	<b>Thermal cut-out of electronic unit</b> (If the refrigeration system has been too heavily loaded, or if the ambient temperature is high, the electronic unit will run too hot).
4	<b>Minimum motor speed error</b> (If the refrigeration system is too heavily loaded, the motor cannot maintain minimum speed at approximately 1,850 rpm).
3	<b>Motor start error</b> (The rotor is blocked or the differential pressure in the refrigeration system is too high (>5 bar)).
2	<b>Fan over-current cut-out</b> (The fan loads the electronic unit with more than 0.65A <sub>peak</sub> ).
1	<b>Battery protection cut-out</b> (The voltage is outside the cut-out setting).

Fig. 6

