

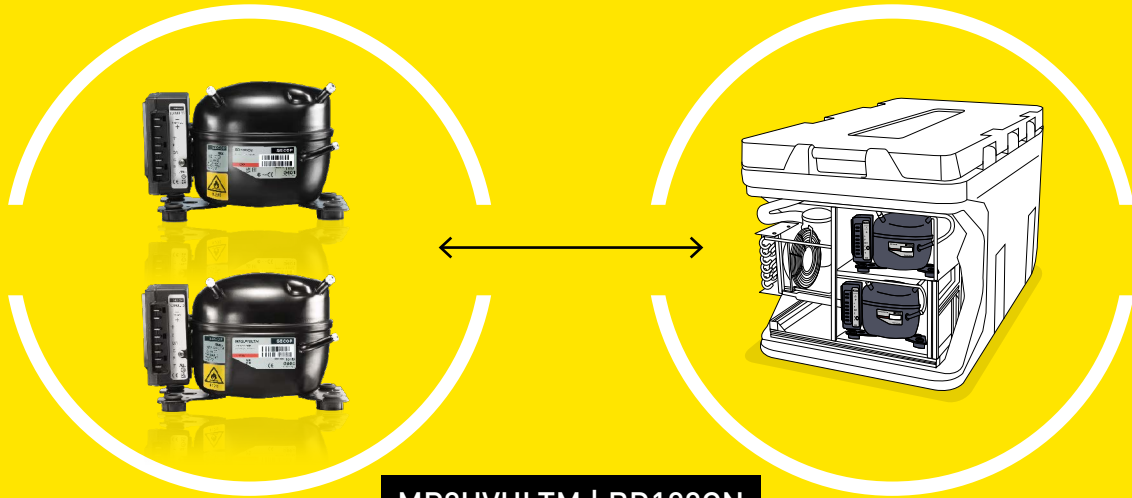





ULT ACTIVE MOBILE MEDICAL COOLING TECHNOLOGY



MP2UVULTM | BD100CN

 <p>DC-Powered Applications</p>	 <p>Variable-Speed Efficiency</p>	 <p>Natural Refrigerants</p>	
 <p>Medical Applications</p>	 <p>Ultra-Low Temperature</p>		

- Safe active fully automated mobile solution based on a 2-stage speed controlled compressor cascade system with a flexible temperature range from -20°C to -86°C even in tropical ambient conditions (43°C)
- Ideal solution for mains voltage independent transport and storage of mRNA-based COVID-19 and Ebola vaccines and CGT specimens
- Low energy consumption and fast pull-down time using low GWP green hydrocarbon refrigerants
- Reliable and precise temperature setting and control and reduced risk of wasting temperature sensitive specimens and vaccines
- Reliable long-lasting system with low TCO life cycle
- Designed for AC/DC global voltage range and optimized for low grid areas
- Easy °CCD® controller customization via Tool4Cool® software

Secop has developed the technology for an ultra-low temperature cooling system. This system is optimized for the last mile of distribution for the new generations of vaccines and offers mobile operation even in high ambient conditions such as in tropical regions.

This dedicated condensing unit features a compressor cascade solution with a **MP2UVULTM** (low stage) and a **BD100CN** (high stage) compressor and takes advantage of Secop's experience in medical applications, vaccine solar freezers, and mobile solutions and combines all of these applications.

Battery-driven active cooling systems for mRNA-based vaccines provide many advantages compared to existing passive cooling (dry ice) transport boxes. Active systems offer temperature control, do not need huge quantities of dry ice, are re-usable, do not waste tons of CO₂, and prevent vaccine wastage.

They are suitable for any distribution point, including in remote areas where the availability of CO₂ cannot be guaranteed or ambient conditions are too severe.

High Stage	BD100CN
Compressor	101Z0401
Electronic unit	101NULT5
Refrigerant	R290

Low Stage	MP2UVULTM
Compressor	101M0800
Electronic unit	101NULT3
Refrigerant	R170

Application		
Compressor	°C	+10 to 43
Possible freezer compartment size	at -86°C	up to 40 liters
Possible freezer compartment temp.	°C	-20 to -86
Evaporating temperature	°C	-90 to -60
Voltage range	V DC	9.6-17 / 21.3-31.5
Weight	kg	13.9

Dimensions

Height | width | depth mm 370.6 | 404 | 189.1

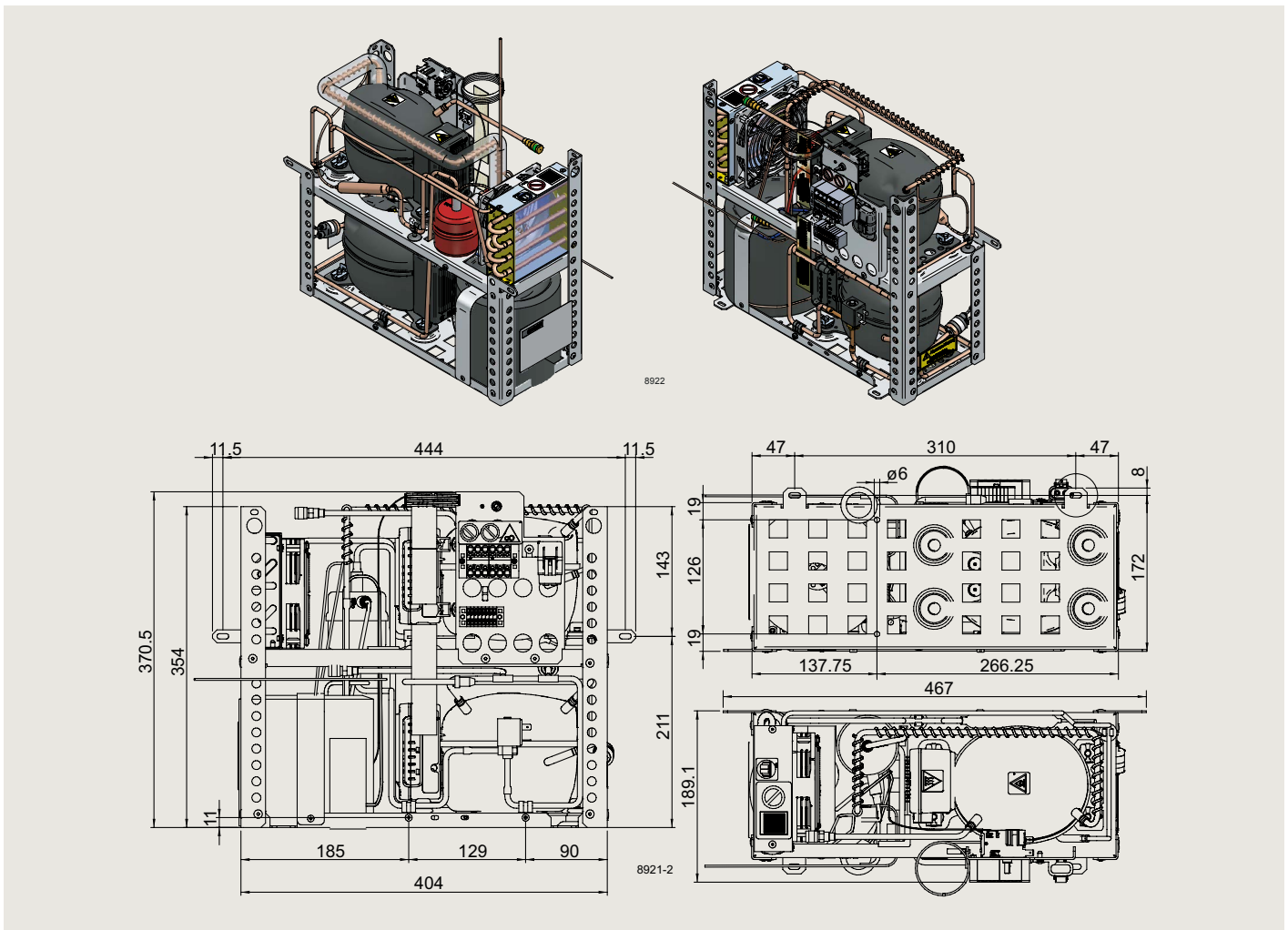

Ultra-Low Temperature Systems

Secop recommends using 2-stage cascade systems for the temperature range from -60°C to -90°C. These have been developed for highest reliability and product safety at ultra-low temperatures.



Learn more about
Ultra-Low Temperature (ULT) Freezers
www.secop.com/ult

Secop GmbH · Lise-Meitner-Str. 29 · 24941 Flensburg, Germany · Tel: +49 461 4941 0 · www.secop.com

Secop accepts no responsibility for possible errors in catalogs, brochures, and other printed material. Secop reserves the right to alter its products without notice. This also applies to products already on order provided that such alterations can be made without consequential changes being necessary to specifications already agreed. All trademarks in this material are the property of the respective companies. Secop and the Secop logotype are trademarks of Secop GmbH. All rights reserved.