

SCE Fusite® Cover with Improved Cord Relief

Until now, Secop, has supplied the 117U1028 cover for the SCE21 compressors with a slim cord relief (see Figure 1).

To ensure improved strength and robustness for our customers, Secop has now improved this connection point as illustrated in Figure 2 and Figure 3. Secop modified the radii of the film hinge to minimize the risk of breaking (see Figure 3).

This change has been tested and accepted by a verification test at the manufacturer and at Secop. Approval adjustments from the customer are not required.

The improved cover will have the same form, fit, and function and is 100% backwards compatible.

Timing and Availability

Existing covers from stock can still be used as before. The improved cover will be available from February 6, 2023.

Code Numbers

The improvement is related to the cover of the following compressors along with their code and type:

Compressor code	Compressor type
104H8163	SCE21CNLX
104H8170	SCE21CNLX
104H8171	SCE21CNLX
104M0811	MS21UDULTM
604H8179	SCE21CNLX
604H8139	SCE21MNX

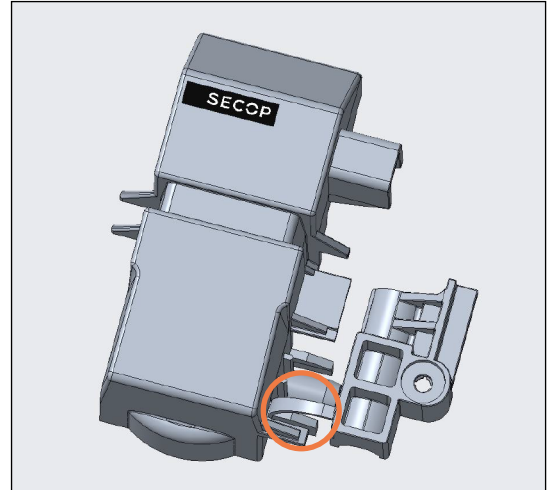

Fig.1 117U1028 cover

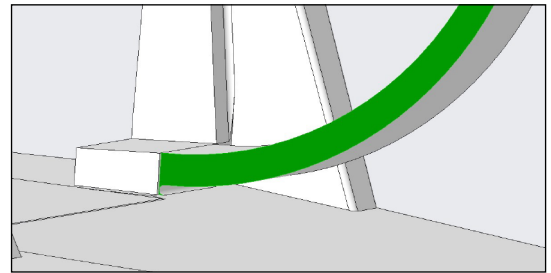

Fig.2 Former cord relief design

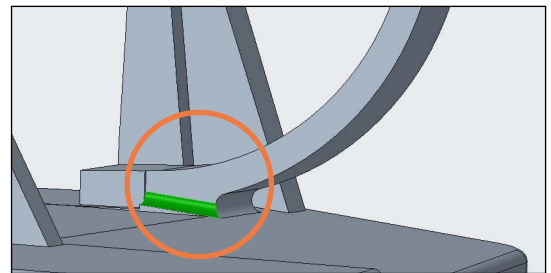

Fig.3 New cord relief design