

## Model

Designation	<b>MN13UVULTM</b>	Sales code:	<b>105M0851</b>
-------------	-------------------	-------------	-----------------

## Compressor design

Oil type	Polyolester	Refrigerant(s)	<b>R290, R170</b>
Oil viscosity	32cST	Displacement	12,55cm <sup>3</sup> / 0,77cu.in
Oil quantity	320cm <sup>3</sup> / 10,8fl.oz	Compressors on pallet	80
Refr. charge - tech. limit	150g / 5,3oz		
Free gas volume comp.	2360cm <sup>3</sup> / 79,8fl.oz		
Weight	10,8kg / 23,8lbs		
Motor protection	2# internal		
Winding resist. ph. to ph.	5,3Ω (at 25°C)		
Max. winding temp.	125°C / 257°F		
Max. discharge temp.	130°C / 266°F		
Additional note	Good robustness against liquid intake. Compressor for laboratory and medical applications. Check special warranty terms with Secop Sales.		



## General - Configurations and Applications with MN13UVULTM and Controller

	<b>Conf. 1</b>	<b>Conf. 2</b>
Sales code single pack:	105N4962	105N4962
Sales code industry pack:	105N4963	105N4963
Power supply (nominal)	100-240V 50/60Hz	100-240V 50/60Hz
Approvals	UL,VDE,CCC	UL,VDE,CCC
Refrigerant	R290	R170
Number of phases	1~ AC	1~ AC
Application	LBP+MBP	ULT
Starting torque	HST	HST
Hot gas defrost	OK	OK
Long interval pull down	OK	OK
System cooling	fan 3m/s	fan 3m/s
Note	- / -	

## Controller functions

	<b>Conf. 1</b>	<b>Conf. 2</b>
Protection	Mechanic	Mechanic
Max output power	1000 W	1000 W
No of relays	2	2
Hot gas defrost	yes	yes
AEO speed setting	yes	yes
Serial speed setting	yes	yes
DWI / Frequency input	yes	yes
Note	US GFCI-Conformity	US GFCI-Conformity

## Model

Designation

**MN13UVULTM**

Sales code:

**105M0851**

## Compressor dimensions

Housing	A Height	218,5mm / 8,6in
	B Height	212,5mm / 8,37in
	C Length shell	205mm / 8,07in
	D Length w. cover	252mm / 9,92in
	E Width	166mm / 6,54in

Connectors		Suction	Discharge	Process
		X	Y	Z
Diameter	[mm]	øi 8,11-8,29	øi 6,41-6,59	øi 6,41-6,59
(i:inside, o:outside)	[in]	øi 0,32-0,33	øi 0,25-0,26	øi 0,25-0,26
Material		copper	copper	copper
Horizontal angle	±2°	0°	0°	0°
Vertical angle	±2°	15°	21°	155°
Position l/h/w	[mm]	132/69/55	94/98/87	-109/93/74
	[in]	5,2/2,7/2,2	3,7/3,9/3,4	-4,3/3,7/2,9
Straight tube l.	[mm]	12	12	12
	[in]	0,5	0,5	0,5

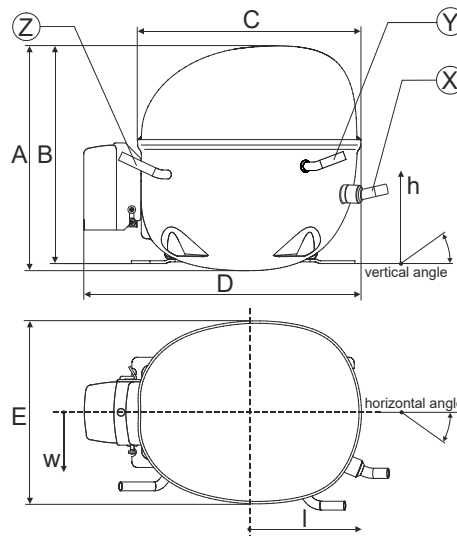

## Compressor fixation

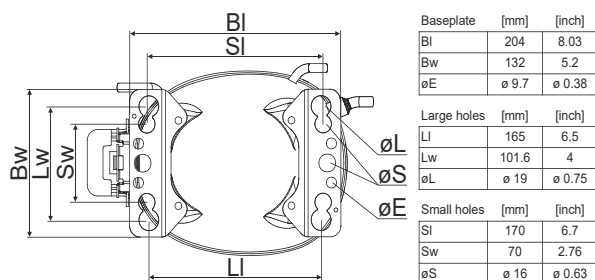

### Bolt joint

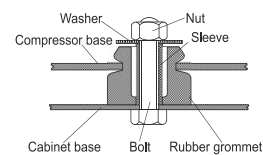

### Snap-on

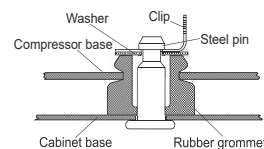

Mounting accessories	one comp.	multi pack
Bolt joint   M6   ø16mm	118-1917	118-1918
Bolt joint   ø1/4"   ø16mm	118-1946	
Bolt joint   ø1/4"   ø19mm	118-1949	
Snap-on   ø7,3   ø16mm	118-1947	118-1919

## Application notes

Operation possible until tilted up to 3 degrees

Provision for PE Grounding is located at the PE Stamp on the compressor

Suction intake without telescope

## Model

Designation	<b>MN13UVULTM</b>	<b>100-240V 50/60Hz</b>	<b>Conf. 1</b>	Sales code:	<b>105M0851</b>
<b>Controller</b>	<b>NLV MV MP US</b>	<b>105N4962</b>			

Sales code single pack:	105N4962 (1 units)
Sales code industry pack:	105N4963 (8 units)
Adaption to compressor:	detached
Protection class:	IP54
Weight:	1,2 kg / 2,64 lbs
Voltage nom.:	100-240V 50/60Hz
Voltage range:	90-150/180-270 V
Max. current:	4,2 A (230 V) / 8,4 A (115 V)
LRA (Locked Rotor Amperage)	1,2 A
Cable length:	915 mm
Compressor speed range:	2000-4500 rpm
Housing plastic:	UL94-5VA

### Controller dimensions:

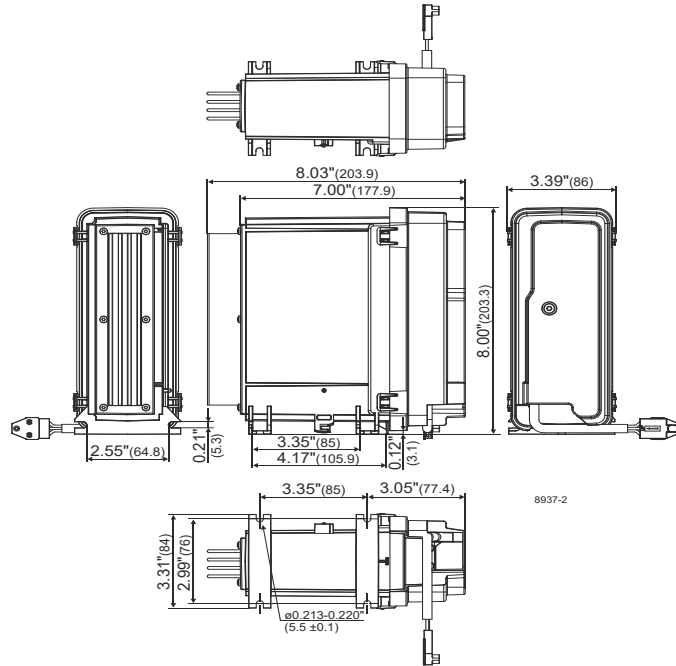

QR Code and Hyperlink leads to the [Operating Instructions.](#)

## Operation Limits

Suctiongas temperature < +20°C (contininuous operation)

## System cooling

Ensure proper airflow of 3 m/s at both compressor and electronic units.  
The airflow for the electronics must be directed to the heat sink.

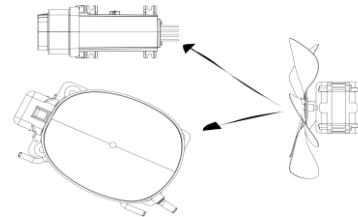

## Ambient/ machineroom temperatures minimum /maximum

Ambient temperature range:	10 - 43°C / 50 - 110°F
Machine room temperature range compressor:	10 - 48°C / 50 - 119°F
Machine room temperature range controller:	10 - 50°C / 50 - 122°F

## Operation pressure range

R290

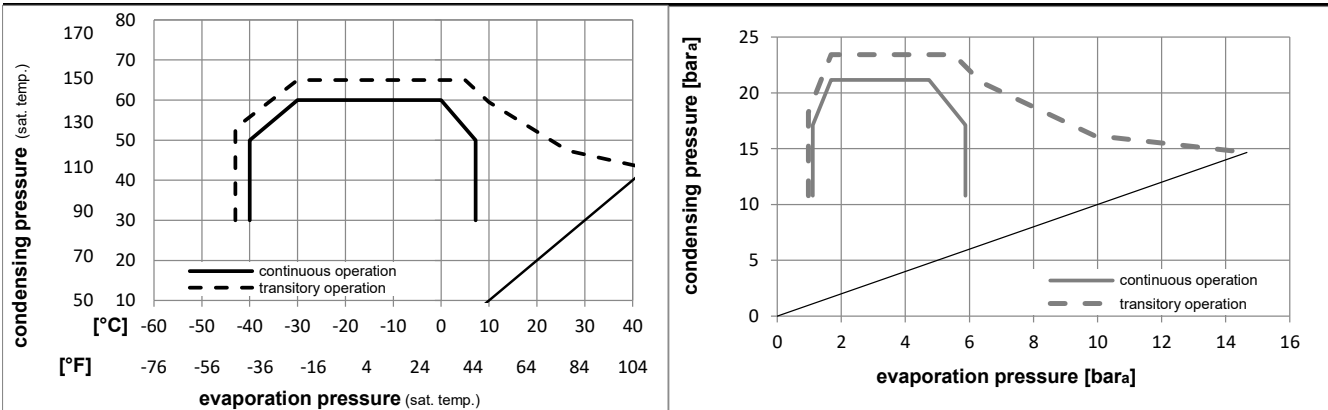

## Model

Designation **MN13UVULTM 100-240V 50/60Hz Conf. 1** Sales code: **105M0851**

Controller **NLV MV MP US** **105N4962**

## Controller connections

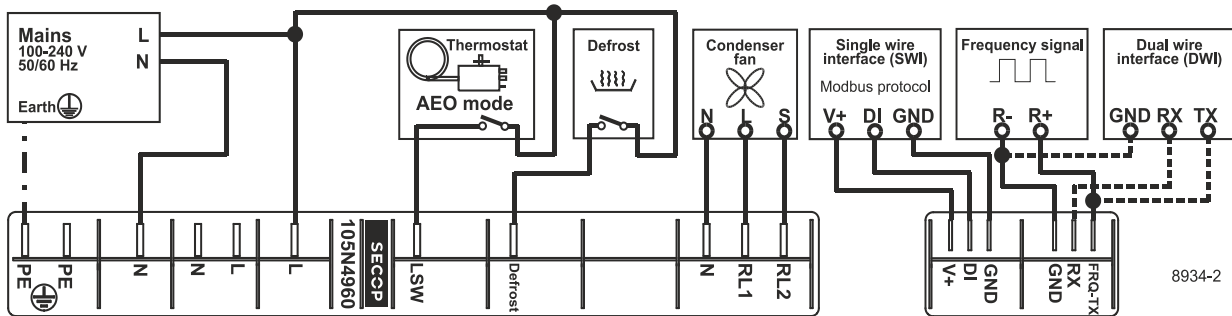
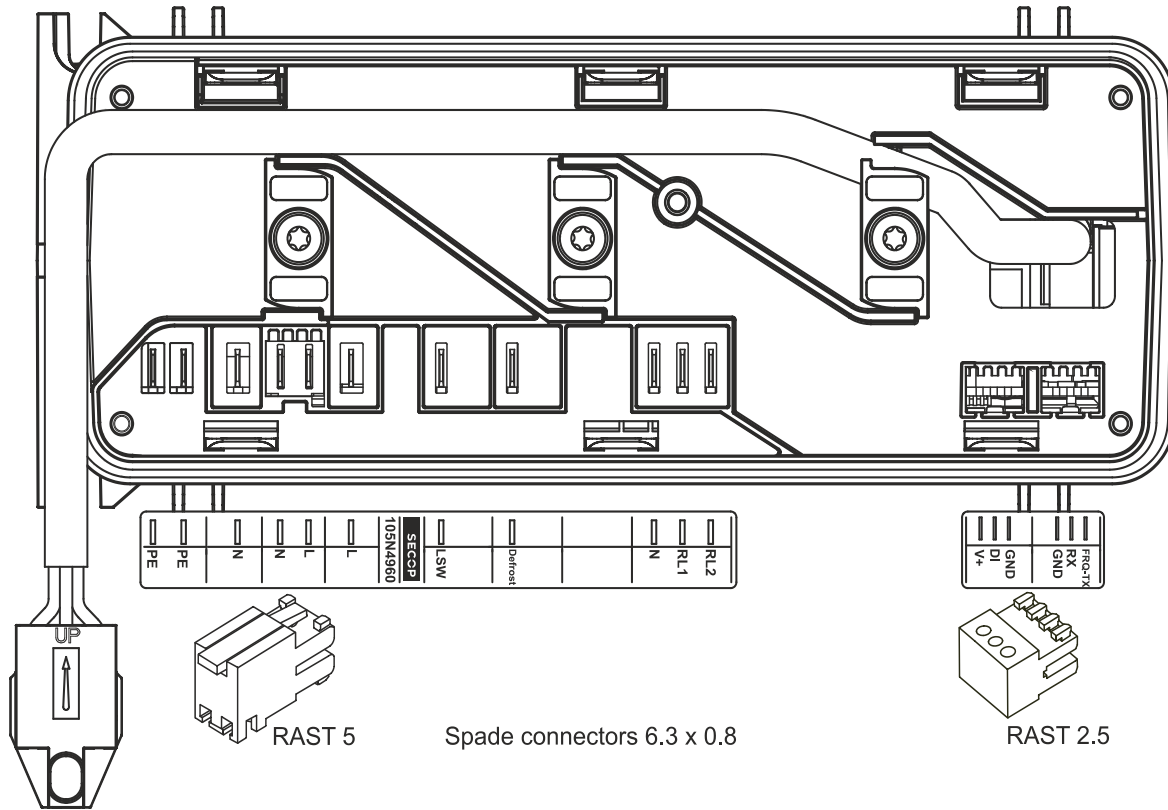

## Accessories (Compressor + Controller) - check operation manual for details

103N2008	plastic cover	1 pcs
103N9110	plastic cover (MP of 103N2008)	80 pcs
103N1004	cord relief	1 pcs

## Model

Designation **MN13UVULTM 100-240V 50/60Hz Conf. 1** Sales code: **105M0851**

Controller **NLV MV MP US** **105N4962**

## Optimization + standard conditions

R290, 220V, 50Hz, Rpm\_N 4500, fan 3m/s

	Evaporating pressure (saturation temperature)				Condensing pressure (saturation temperature)						Power consumption			ASHRAE LBP			
	pe	pc	Return gas temp.		Cooling capacity			COP	EER	[kcal/Wh]	P1	Current consumption			Ref. mass flow		
			RGT	Tliq	[W]	[Btu/h]	[kcal/h]					[W/W]	[Btu/Wh]			[A]	ṁ
[°C]	[°F]	[°C]	[°F]	[W]	[Btu/h]	[kcal/h]	[W/W]	[Btu/Wh]	[kcal/Wh]	[W]	[A]	[kg/h]					
[°C]	-23	54	32	32	948,7	3240	816,5	1,77	6,06	1,53	534,9	2,91	9,61	ASHRAE LBP			
[°F]	-10	130	90	90													
[°C]	-25	55	32	55	711,3	2429	612,2	1,38	4,72	1,19	514,4	2,80	8,86	cecomaf LBP			
[°F]	-13	131	90	131													
[°C]	-35	40	20	40	543,4	1856	467,7	1,53	5,21	1,31	356,2	1,94	6,21	EN12900 LBP			
[°F]	-31	104	68	104													
[°C]	-7	54	35	46	1677,8	5730	1443,9	2,19	7,48	1,88	766,0	4,16	19,14	ASHRAE MBP			
[°F]	20	130	95	115													
[°C]	-10	55	32	55	1335,8	4562	1149,6	1,85	6,31	1,59	722,5	3,93	16,90	cecomaf MBP			
[°F]	14	131	90	131													
[°C]	-10	45	20	45	1501,8	5129	1292,5	2,29	7,83	1,97	655,1	3,56	18,44	EN12900 MBP			
[°F]	14	113	68	113													

## Standard conditions with different RPM

R290, 220V, 50Hz, Rpm\_N 4500, fan 3m/s

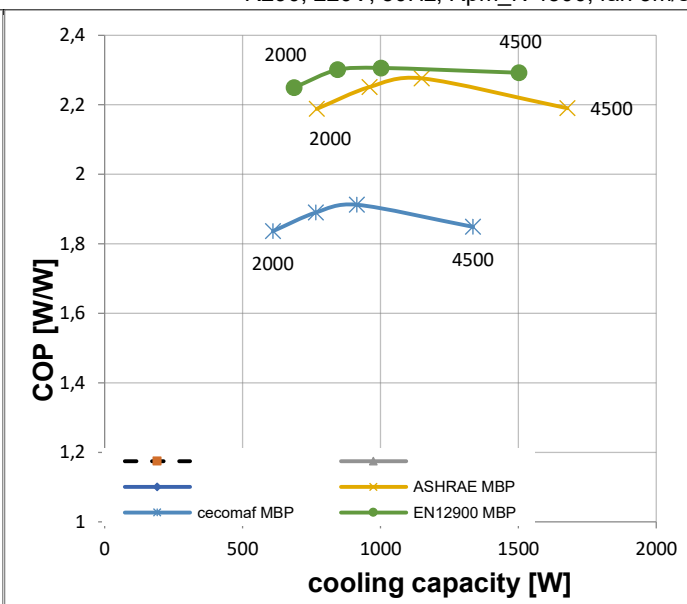
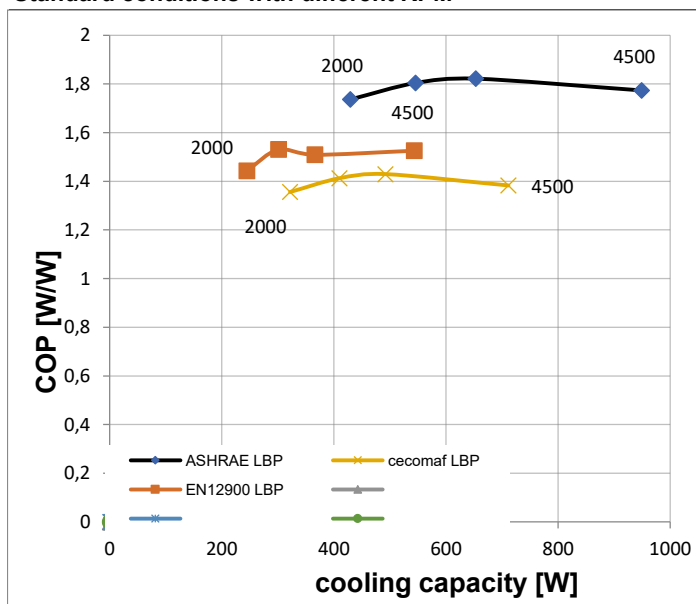

## Test conditions:

	pe [°C]	pc [°C]	Tliq [°C]	Tsuc [°C]		pe [°C]	pc [°C]	Tliq [°C]	Tsuc [°C]
ASHRAE LBP	-23,33	54,44	32,22	32,22	ASHRAE MBP	-6,66	54,44	46,11	35
cecomaf LBP	-25	55	55	32	cecomaf MBP	-10	55	55	32
EN12900 LBP	-35	40	40	20	EN12900 MBP	-10	45	45	20

## Model

Designation	<b>MN13UVULTM</b>	<b>100-240V 50/60Hz</b>	<b>Conf. 2</b>	Sales code:	<b>105M0851</b>
Controller	<b>NLV MV MP US</b>				<b>105N4962</b>

Sales code single pack:	105N4962 (1 units)
Sales code industry pack:	105N4963 (8 units)
Adaption to compressor:	detached
Protection class:	IP54
Weight:	1,2 kg / 2,64 lbs
Voltage nom.:	100-240V 50/60Hz
Voltage range:	90-150/180-270 V
Max. current:	4,2 A (230 V) / 8,4 A (115 V)
LRA (Locked Rotor Amperage)	1,2 A
Cable length:	915 mm
Compressor speed range:	2000-4500 rpm
Housing plastic:	UL94-5VA

### Controller dimensions:

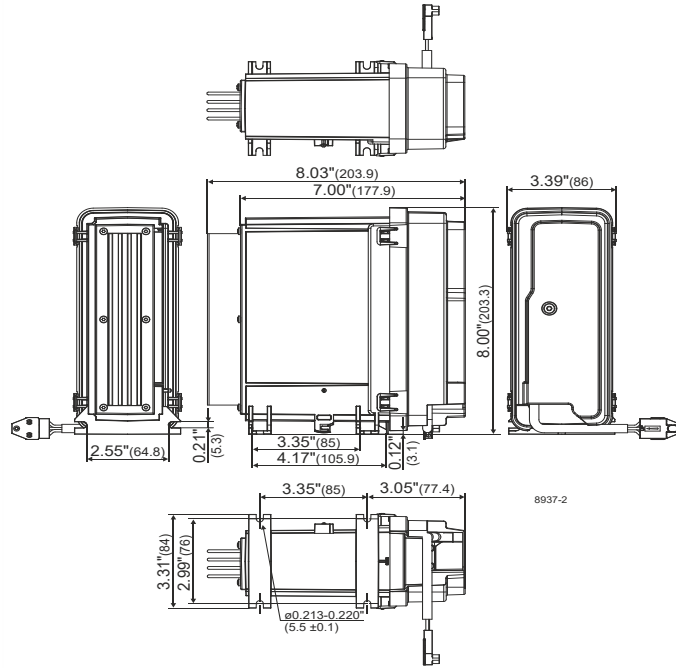

QR Code and Hyperlink leads to the [Operating Instructions.](#)

## Operation Limits

Suction gas temperature < +20°C (continuous operation)

### Ambient/ machineroom temperatures minimum /maximum

Ambient temperature range:	10 - 43°C / 50 - 110°F
Machine room temperature range compressor:	10 - 48°C / 50 - 119°F
Machine room temperature range controller:	10 - 50°C / 50 - 122°F

## System cooling

Ensure proper airflow of 3 m/s at both compressor and electronic units.  
The airflow for the electronics must be directed to the heat sink.

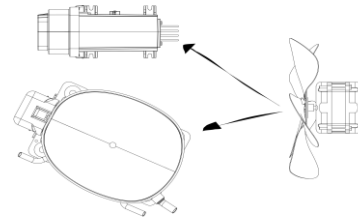

## Operation pressure range

R170

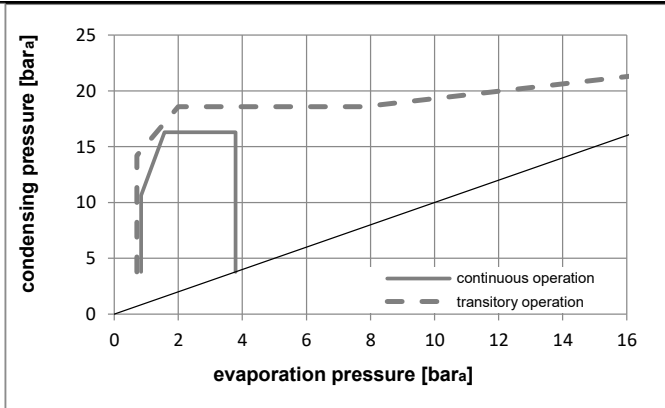
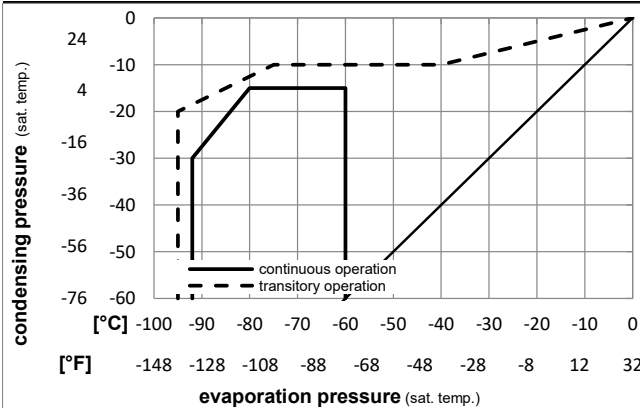

## Model

Designation **MN13UVULTM 100-240V 50/60Hz Conf. 2** Sales code: **105M0851**

Controller **NLV MV MP US** **105N4962**

## Controller connections

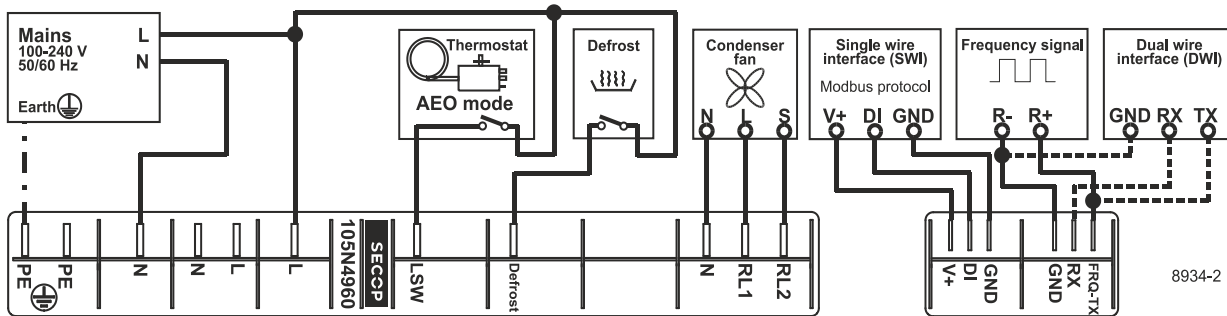
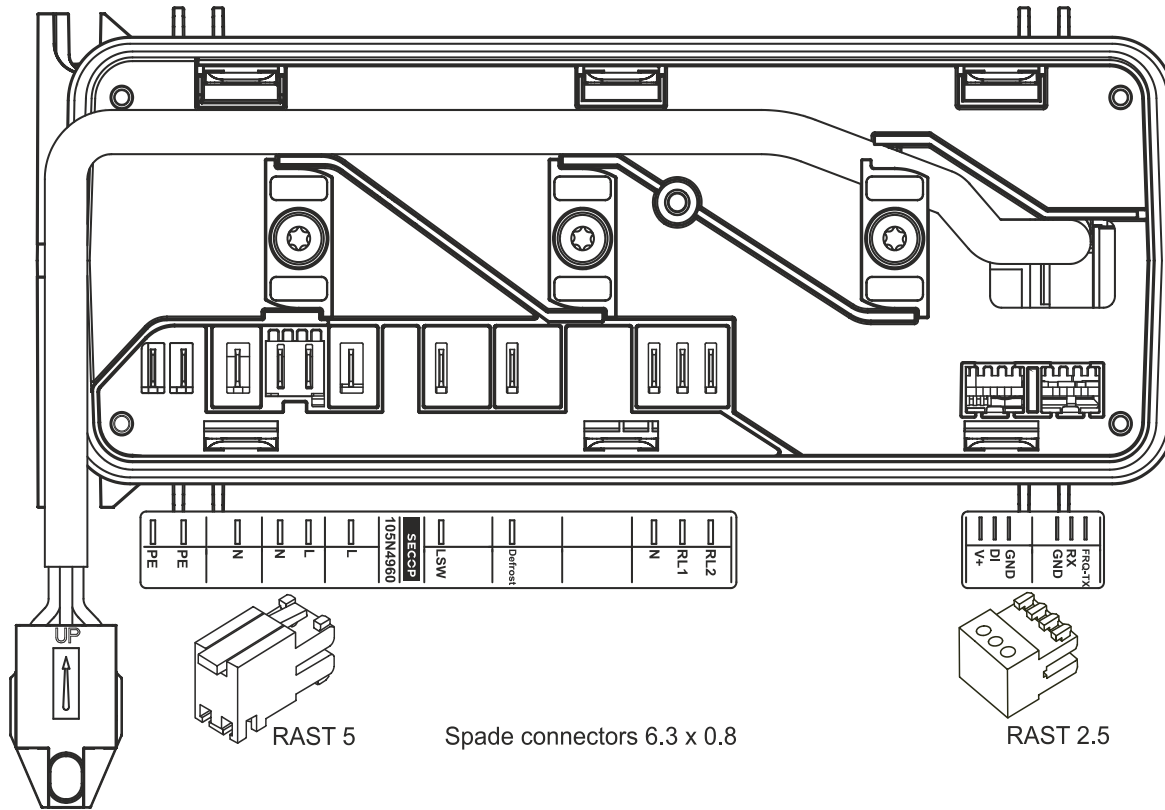

## Accessories (Compressor + Controller) - check operation manual for details

103N2008	plastic cover	1 pcs
103N9110	plastic cover (MP of 103N2008)	80 pcs
103N1004	cord relief	1 pcs

### Model

Designation **MN13UVULTM 100-240V 50/60Hz Conf. 2** Sales code: **105M0851**

Controller **NLV MV MP US** **105N4962**

### Optimization + standard conditions

R170, 220V, 50Hz, Rpm\_N 4500, fan 3m/s

	Evaporating pressure (saturation temperature)				Condensing pressure (saturation temperature)						Power consumption			Ref. mass flow ṁ [kg/h]
	pe	pc	RGT	Tliq	Cooling capacity			COP	EER		P1	I		
	[°C]	[°C]	[°C]	[°C]	[W]	[Btu/h]	[kcal/h]	[W/W]	[Btu/Wh]	[kcal/Wh]	[W]	[A]		
ULT 1	-90 [°F] ###	-15 5	10 50	-15 5	277,0	946	238,4	1,04	3,56	0,90	265,9	1,21	2,25	
ULT 2	-90 [°F] ###	-20 -4	10 50	-20 -4	307,1	1049	264,3	1,15	3,92	0,99	267,5	1,22	2,41	
ULT 3	-90 [°F] ###	-25 -13	10 50	-25 -13	336,7	1150	289,8	1,27	4,33	1,09	265,3	1,21	2,56	
ULT 4	-90 [°F] ###	-30 -22	10 50	-30 -22	365,7	1249	314,7	1,41	4,81	1,21	259,7	1,18	2,70	
ULT 5	-90 [°F] ###	-35 -31	10 50	-35 -31	393,9	1345	339,0	1,57	5,36	1,35	250,9	1,14	2,82	
ULT 6	-90 [°F] ###	-40 -40	10 50	-40 -40	421,3	1439	362,6	1,76	6,01	1,51	239,3	1,09	2,94	

### Standard conditions with different RPM

R170, 220V, 50Hz, fan 3m/s

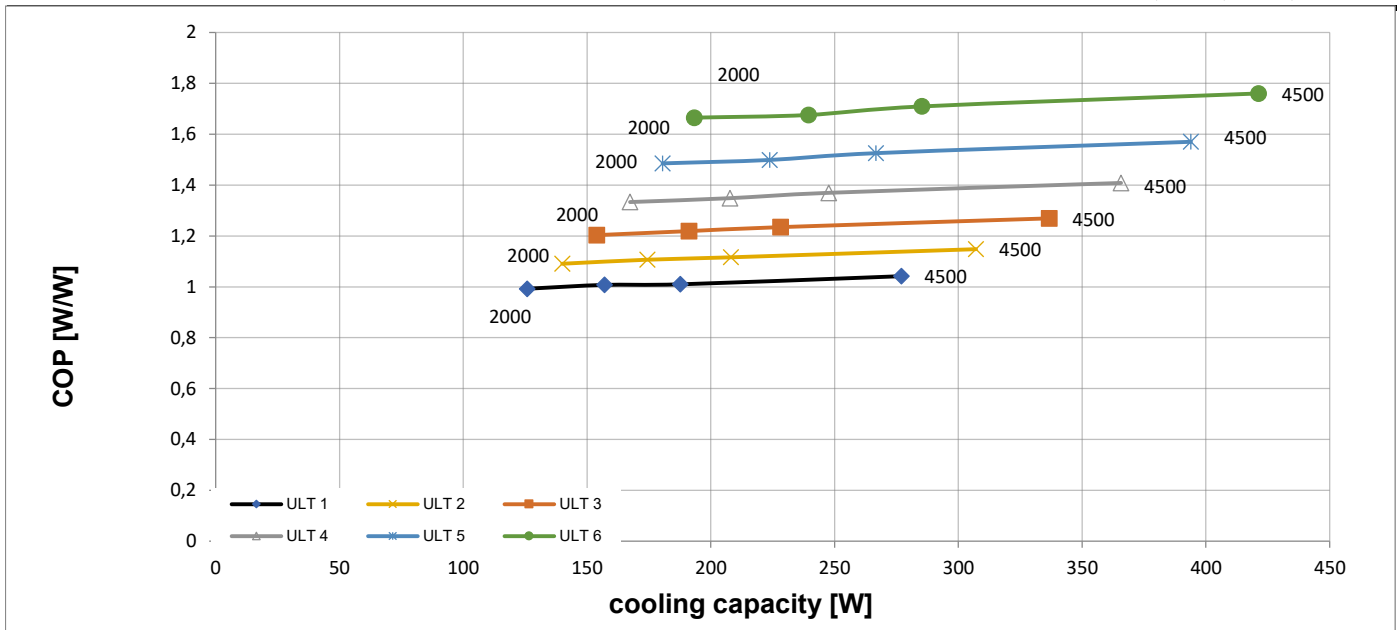

Test conditions:	pe [°C]	pc [°C]	Tliq [°C]	Tsuc [°C]
ULT 1	-90	-15	-15	10
ULT 2	-90	-20	-20	10
ULT 3	-90	-25	-25	10
ULT 4	-90	-30	-30	10
ULT 5	-90	-35	-35	10
ULT 6	-90	-40	-40	10