

Instructions

NLV Compressors
220-240V 50/60Hz
105N4120
Controllers

SECCP

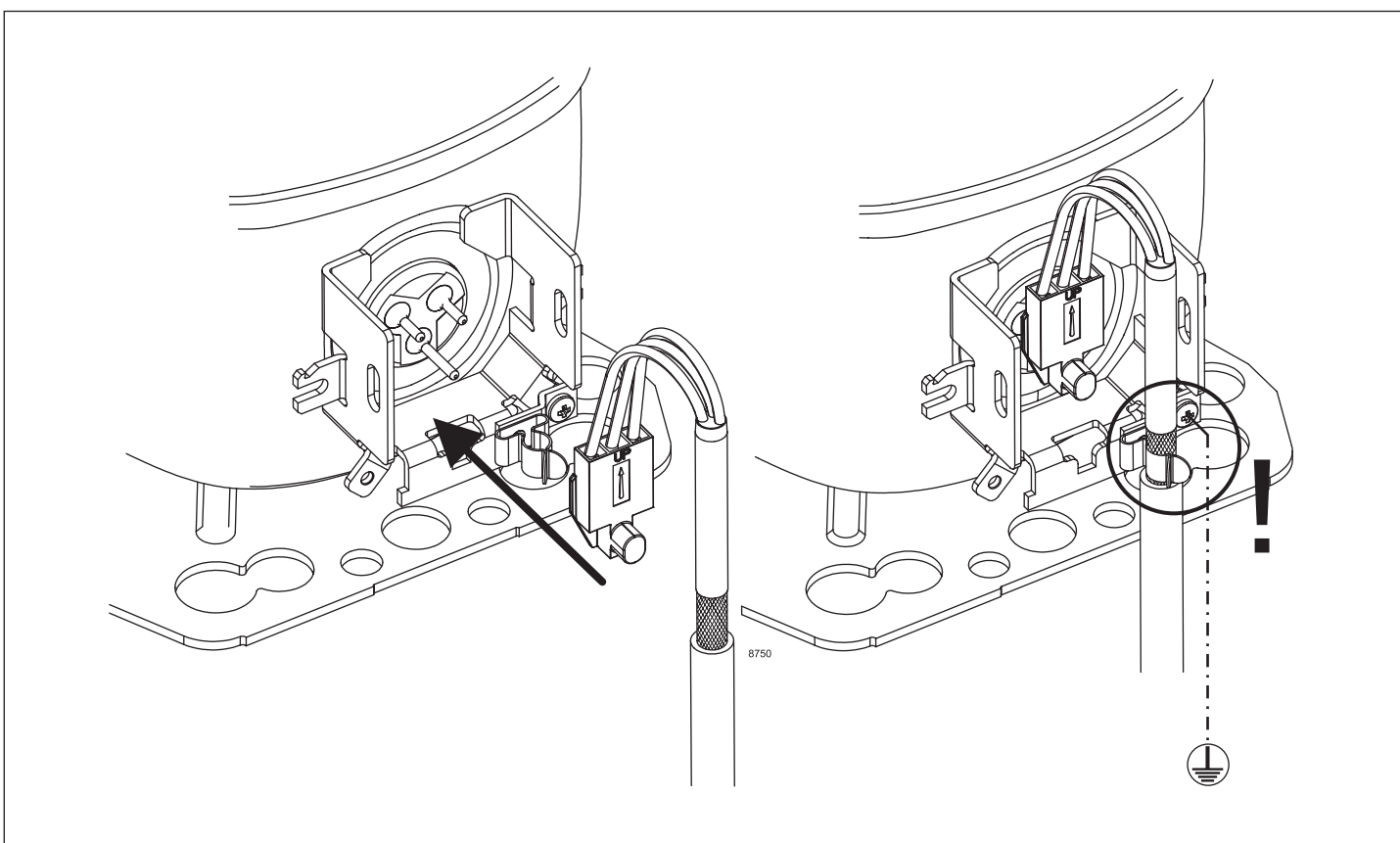

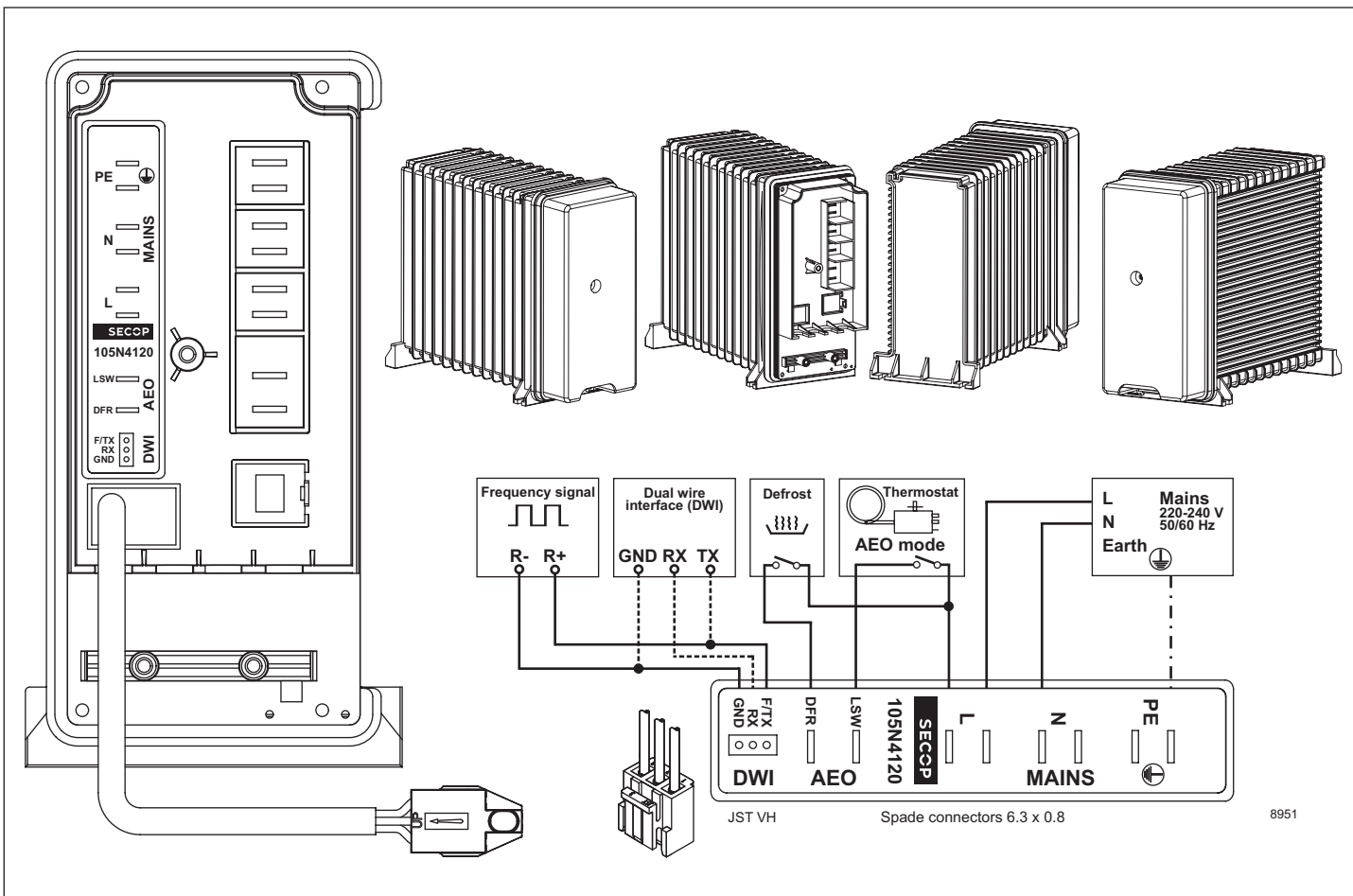
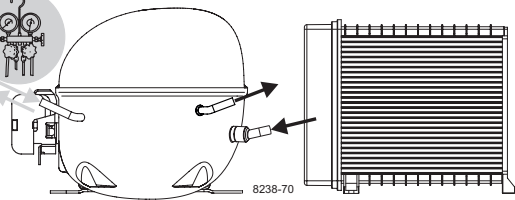

Instructions

NLV Compressors
220-240V 50/60Hz
105N4120
Controllers

SECCP



Service/Repair R290



Brazing on Suction Connectors (Direct Intake)

representative image

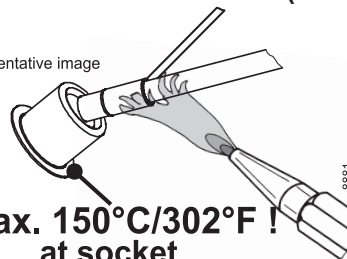

**! max. 150°C/302°F!
at socket**

brazing solder: phosphor (LP7) or silver

Refer to Product Bulletin: **Brazing on Suction Connectors
(Compressors with Direct Suction Intake)**

Ensure Proper Airflow of 3 m/s at Both Compressor and Electronic Unit (Heatsink)

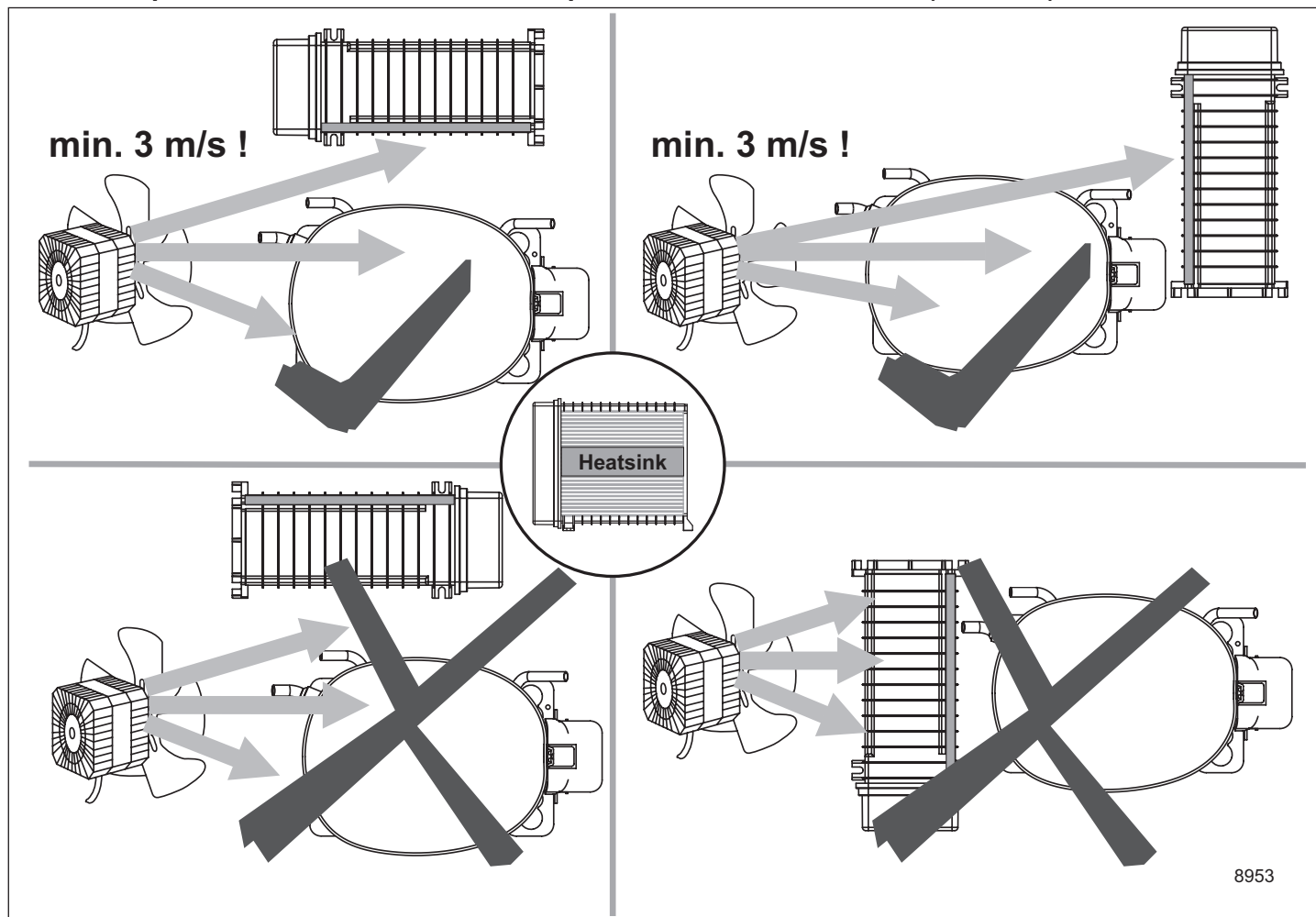

Airflow	3 m/s
Operating conditions	+ 5 °C to 43 °C - humidity < 90 % rH non condensing
Storage conditions	-25 °C to 70 °C - humidity < 90 % rH non condensing
Supply voltage	220-240 V (± 10 %)
Frequency	50/60 Hz
Input power, max.	1000 W

Secop accepts no responsibility for possible errors in catalogs, brochures, and other printed material. Secop reserves the right to alter its products without notice. This also applies to products already on order provided that such alterations can be made without subsequent changes being necessary to specifications already agreed. All trademarks in this material are the property of the respective companies. Secop and the Secop logotype are trademarks of Secop GmbH. All rights reserved. www.secop.com