

## BD1.4F-AUTO.3 Direct Current Compressor R134a 12V DC

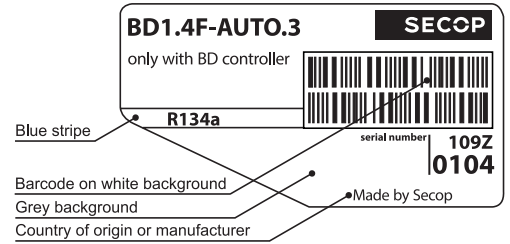

### General

Code number (without electronic unit)	109Z0104
Electronic unit - Automotive	101N1010, 30 pcs: 101N1011
Approvals	-
Compressors on pallet	180

### Application

Application		LBP/MBP
Evaporating temperature	°C	-25 to 5
Voltage range	VDC	8.5 - 17
Max. condensing temperature continuous (short)	°C	60 (70)
Max. winding temperature continuous (short)	°C	125 (135)

- S = Static cooling normally sufficient
- O = Oil cooling
- F<sub>1</sub> = Fan cooling 1.5 m/s  
(compressor compartment temperature equal to ambient temperature)
- F<sub>2</sub> = Fan cooling 3.0 m/s necessary
- SG = Suction gas cooling normally sufficient
- = not applicable in this area

### Cooling requirements

Application	LBP	MBP	HBP
32°C	S	S	-
38°C	S	S	-
43°C	S	S	-

Remarks on application:  
**New generation with optimized noise level during rough vehicle motions.**

### Motor

Motor type		permanent magnet, brushless DC
Speed	rpm	3,000
Resistance, all 3 windings (25°C)	mΩ	370

### Design

Displacement	cm <sup>3</sup>	1.41
Oil quantity (type)	cm <sup>3</sup>	75 (polyolester)
Maximum refrigerant charge	g	70
Free gas volume in compressor	cm <sup>3</sup>	500
Weight - Compressor/Electronic unit	kg	2.1/0.17

### Standard battery protection settings (refer to 101N1000 Instructions for optional settings)

Voltage		Min. value	Default	Max. value
Cut out (0.1 steps)	VDC	8.5	8.5	17
Cut in diff. (0.1 steps)	VDC	0.5	0.5	8

### Dimensions

Height	mm	A	96.25
		B	91.25
		B1	88.00
		B2	25.20
Suction connector	location/I.D. mm   angle	C	6.2   25°
		material   comment	Cu-plated steel   Al cap
Process connector	location/I.D. mm   angle	D	6.2   25°
		material   comment	Cu-plated steel   Al cap
Discharge connector	location/I.D. mm   angle	E	5.0   0°
		material   comment	Cu-plated steel   Al cap
Connector tolerance	I.D. mm	±0.09, on 5.0 +0.12/+0.20	
Remarks			

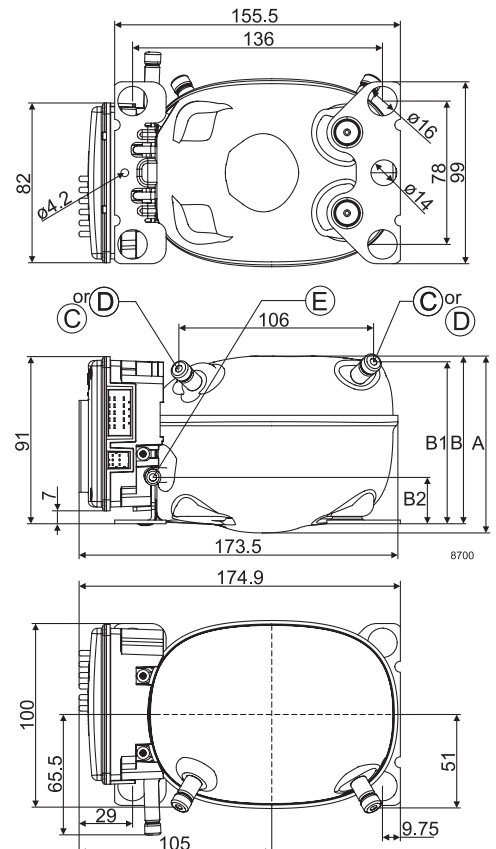

### EN 12900 Household (CECOMAF)

Evap. temp. in °C	-25	-23.3	-20	-15	-10	-6.7	-5	0	5
Capacity in W	14.3	17.5	24.3	36.1	50.0	60.5	66.4	85.5	108
Power cons. in W	26.1	27.5	30.3	35.0	40.0	43.4	45.2	50.4	55.6
Current cons. in A	1.98	2.08	2.30	2.65	3.03	3.29	3.42	3.82	4.21
COP in W/W	0.55	0.64	0.80	1.03	1.25	1.39	1.47	1.70	1.94

### EN 12900 Household (CECOMAF)

Evap. temp. in °F	-13	-10	0	10	14	20	30	40	41
Capacity in W	14.3	17.5	29.3	43.6	50.0	60.6	81.0	105	108
Power cons. in W	26.1	27.5	32.3	37.7	40.0	43.4	49.3	55.0	55.6
Current cons. in A	1.98	2.08	2.45	2.86	3.03	3.29	3.73	4.17	4.21
COP in W/W	0.55	0.64	0.91	1.15	1.25	1.40	1.64	1.91	1.94

### ASHRAE LBP

Evap. temp. in °F	-13	-10	0	10	14	20	30	40	41
Capacity in BTU/h	61.8	75.1	125	185	212	257	344	446	457
Power cons. in W	26.2	27.5	32.3	37.7	39.9	43.4	49.1	54.8	55.3
Current cons. in A	1.98	2.08	2.45	2.86	3.03	3.28	3.72	4.15	4.19
ERR in BTU/h	2.36	2.73	3.86	4.91	5.32	5.94	7.00	8.15	8.27

### ASHRAE LBP

Evap. temp. in °C	-25	-23.3	-20	-15	-10	-6.7	-5	0	5
Capacity in W	18.1	22.1	30.5	45.0	62.3	75.3	82.6	106	134
Power cons. in W	26.2	27.5	30.3	35.0	39.9	43.3	45.1	50.3	55.3
Current cons. in A	1.98	2.08	2.30	2.65	3.03	3.28	3.42	3.81	4.19
COP in W/W	0.69	0.80	1.00	1.29	1.56	1.74	1.83	2.12	2.43

Test conditions	EN 12900/CECOMAF	ASHRAE LBP
Condensing temperature	55°C	54.4°C
Ambient temperature	32°C	32°C
Suction gas temperature	32°C	32°C
Liquid temperature	no subcooling	32°C

### Operational errors

Error code	Error type
	Can be read out in the software TOOL4COOL®
7	<b>Communication failure</b>
6	<b>Thermostat failure</b> (If the NTC thermistor is short-circuit or has no connection, the electronic unit will enter manual mode).
5	<b>Thermal cut-out of electronic unit</b> (If the refrigeration system has been too heavily loaded, or if the ambient temperature is high, the electronic unit will run too hot).
4	<b>Minimum motor speed error</b> (If the refrigeration system is too heavily loaded, the motor cannot maintain minimum speed at approximately 1,850 rpm).
3	<b>Motor start error</b> (The rotor is blocked or the differential pressure in the refrigeration system is too high (>5 bar)).
2	<b>Fan over-current cut-out</b> (The fan loads the electronic unit with more than 0.65A <sub>peak</sub> ).
1	<b>Battery protection cut-out</b> (The voltage is outside the cut-out setting).

### Accessories for BD1.4F-AUTO.3

Mounting	Code number
Bolt joint for one compressor Ø: 16 mm	118-1917
Bolt joint in quantities Ø: 16 mm	118-1918
Snap-on in quantities Ø: 16 mm	118-1919
One Wire/LIN gateway	105N9501
Not deliverable from Secop	
Automobile fuse DIN 7258	15A

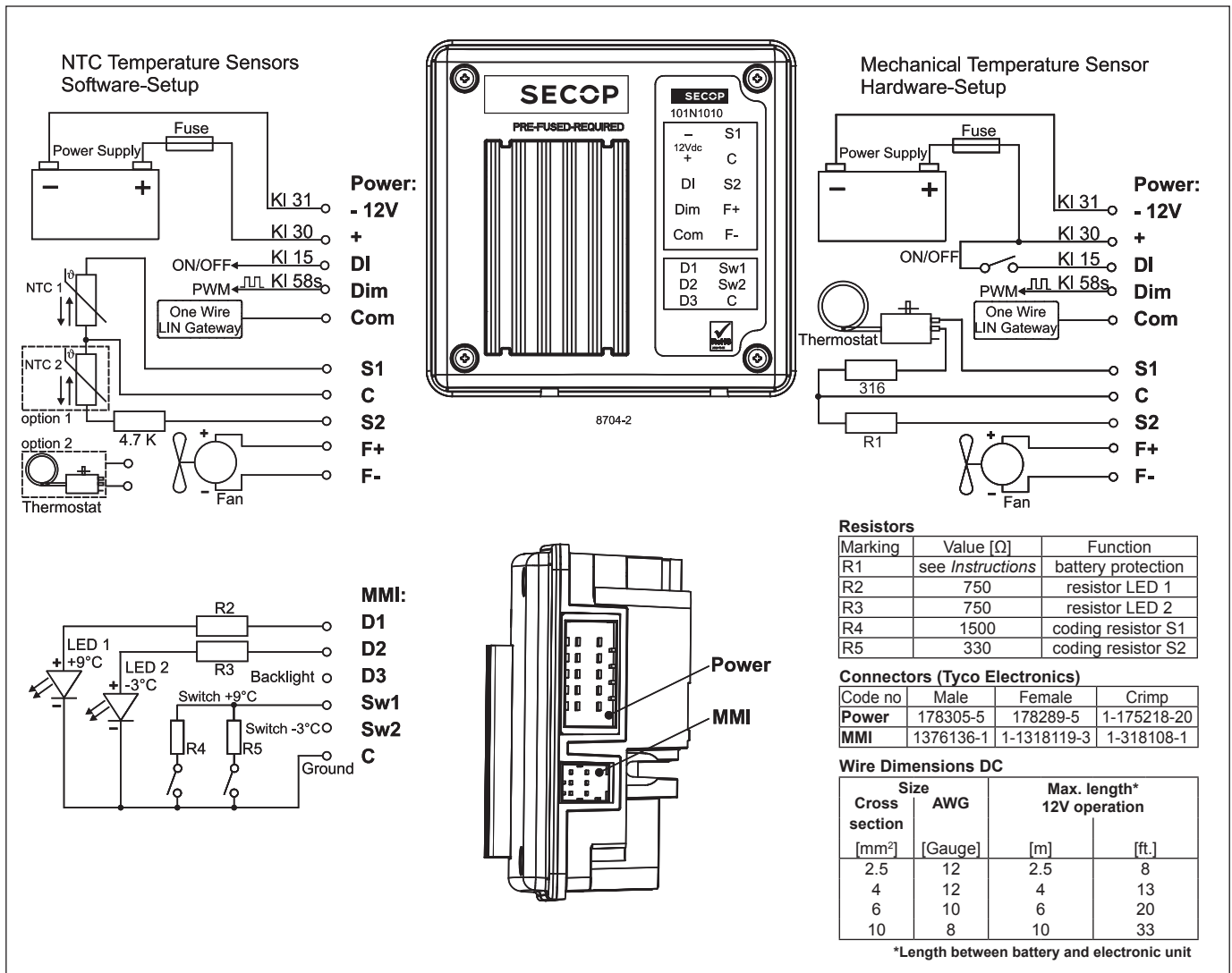

Nidec GA Compressors accepts no responsibility for possible errors in catalogs, brochures, and other printed material. Nidec GA Compressors reserves the right to alter its products without notice. This also applies to products already on order provided that such alterations can be made without consequential changes being necessary to specifications already agreed. All trademarks in this material are the property of the respective companies. Secop and the Secop logotype are trademarks of Nidec Global Appliance Germany GmbH. All rights reserved. [www.secop.com](http://www.secop.com)