

## BD1.4F-VSD.2 Direct Current Compressor R134a, 12/24V DC & 100-240V AC 50/60Hz



### General

Code number (without electronic units)	109Z0206
Electronic unit - Variable Speed	101N2100, 30 pcs: 101N2101
Electronic unit - Variable Speed w. AC/DC converter	101N5100, 24 pcs: 101N5101
Approvals	UL
Compressors on pallet	180

### Application

Application		LBP/MBP/HBP
Evaporating temperature	°F	-20 to 59
Voltage range DC	VDC	9.6 - 17 / 19 - 34
Voltage range AC	V/Hz	100 - 240 / 50 - 60
Max. condensing temperature continuous (short)	°F	140 (158)
Max. winding temperature continuous (short)	°F	257 (275)

### Cooling requirements

Application	LBP	MBP	HBP
32°C	S	S	S
38°C	S	S	S
43°C	S	S	S

Remarks on application:

**New generation with optimized noise level during rough vehicle motions.**

### Motor

Motor type		permanet magnet, brushless DC
Speed		variable speed
Resistance, all 3 windings (25°C)	mΩ	210

### Design

Displacement	cu.in.	0.086
Oil quantity (type)	fl.oz.	2.64 (polyolester)
Maximum refrigerant charge	oz.	2.47
Free gas volume in compressor	fl.oz.	17.60
Weight - Compressor/Electronic unit	lbs.	4.63 / 0.24 (DC) / 0.64 (AC/DC)

**Standard battery protection settings** (refer to 101N2100/5100 *Instructions* for optional settings)

Voltage (0.1 steps)			Min. value	Default	Max. value	
12V	± 0.3V DC, all values	Cut out	VDC	9.6	10.4	17
		Cut in diff.	VDC	0.5	1.3	10
24V	± 0.3V DC, all values	Cut out	VDC	19	21.3	27
		Cut in diff.	VDC	0.5	1.3	10

### Dimensions

Height	inch	A	3.79
		B	3.59
		B1	3.46
		B2	0.99
Suction connector	location/I.D. inch   angle	C	0.252-0.259   25°
	material   comment		Cu-plated steel   Al cap
Process connector	location/I.D. inch   angle	D	0.252-0.259   25°
	material   comment		Cu-plated steel   Al cap
Discharge connector	location/I.D. inch   angle	E	0.202-0.205   0°
	material   comment		Cu-plated steel   Al cap

Remarks: **inch connectors**

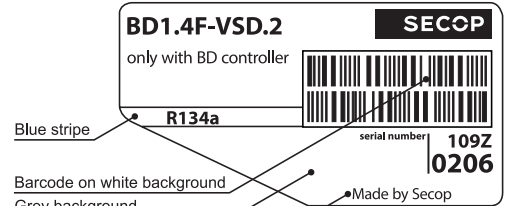

Blue stripe

Barcode on white background

Grey background

Country of origin or manufacturer

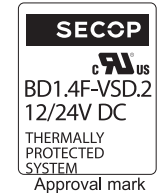

S = Static cooling normally sufficient

O = Oil cooling

F<sub>1</sub> = Fan cooling 1.5 m/s

(compressor compartment temperature equal to ambient temperature)

F<sub>2</sub> = Fan cooling 3.0 m/s necessary

SG = Suction gas cooling normally sufficient

- = not applicable in this area

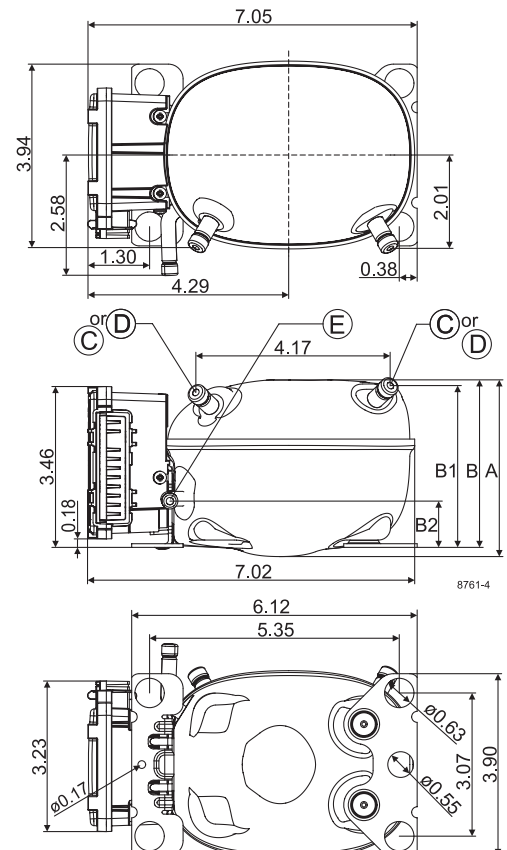

**Capacity (ASHRAE LBP) 12V DC, static cooling BTU/h**

rpm \ °F	-20	-13	-10	0	10	14	20	30	41	45	50	59
2,000		39	47	77	116	133	162	219	290	319	357	431
3,000	44	69	82	130	190	217	261	344	448	488	543	648
3,500	52	83	98	156	227	258	309	406	525	573	635	756
4,000	61	98	115	182	264	300	358	468	604	657	728	865

**Capacity (EN 12900 Household/CECOMAF) 12V DC, static cooling watt**

rpm \ °F	-20	-13	-10	0	10	14	20	30	41	45	50	59
2,000		9	11	18	27	31	38	51	68	75	84	101
3,000	10	16	19	31	45	51	61	81	105	115	128	152
3,500	12	20	23	37	54	61	73	96	124	135	150	178
4,000	14	23	27	43	62	71	85	110	142	155	172	203

**Power consumption 12V DC, static cooling watt**

rpm \ °F	-20	-13	-10	0	10	14	20	30	41	45	50	59
2,000		16	17	20	24	25	28	33	39	41	44	50
3,000	20	24	26	31	37	39	43	49	56	59	62	68
3,500	24	29	31	37	44	47	51	58	65	68	71	78
4,000	28	34	36	44	52	55	59	67	75	77	81	87

**Current consumption (for 24V applications the following must be halved) A**

rpm \ °F	-20	-13	-10	0	10	14	20	30	41	45	50	59
2,000		1.25	1.33	1.59	1.89	2.02	2.22	2.58	3.02	3.18	3.40	3.81
3,000	1.56	1.84	1.96	2.37	2.81	2.99	3.26	3.74	4.29	4.49	4.75	5.24
3,500	1.86	2.19	2.34	2.82	3.33	3.53	3.84	4.38	4.98	5.20	5.49	6.01
4,000	2.19	2.58	2.75	3.31	3.88	4.11	4.46	5.05	5.71	5.95	6.26	6.82

**EER (ASHRAE LBP) 12V DC, static cooling BTU/h**

rpm \ °F	-20	-13	-10	0	10	14	20	30	41	45	50	59
2,000		2.51	2.83	3.87	4.89	5.27	5.83	6.69	7.54	7.82	8.16	8.73
3,000	2.15	2.87	3.18	4.17	5.15	5.53	6.09	7.03	8.03	8.38	8.83	9.61
3,500	2.17	2.89	3.19	4.17	5.14	5.52	6.09	7.05	8.10	8.47	8.95	9.81
4,000	2.18	2.89	3.19	4.15	5.12	5.50	6.07	7.04	8.12	8.52	9.03	9.95

**COP (EN 12900 Household/CECOMAF) 12V DC, static cooling W/W**

rpm \ °F	-20	-13	-10	0	10	14	20	30	41	45	50	59
2,000		0.59	0.66	0.91	1.15	1.24	1.37	1.57	1.76	1.82	1.90	2.03
3,000	0.50	0.67	0.74	0.98	1.21	1.30	1.43	1.65	1.88	1.96	2.06	2.24
3,500	0.51	0.68	0.75	0.98	1.21	1.30	1.44	1.66	1.90	1.99	2.10	2.29
4,000	0.50	0.68	0.75	0.98	1.21	1.30	1.43	1.66	1.91	2.00	2.12	2.32

**Operational errors (TOOL4COOL® or LED flashes)**

Error code or LED flashes	Error type
	Can be read out in the software TOOL4COOL®
6	<b>Thermostat failure</b> (If the NTC thermistor is short-circuit or has no connection, the electronic unit will enter manual mode).
5	<b>Thermal cut-out of electronic unit</b> (If the refrigeration system has been too heavily loaded, or if the ambient temperature is high, the electronic unit will run too hot).
4	<b>Minimum motor speed error</b> (If the refrigeration system is too heavily loaded, the motor cannot maintain minimum speed at approximately 1,850 rpm).
3	<b>Motor start error</b> (The rotor is blocked or the differential pressure in the refrigeration system is too high (>5 bar)).
2	<b>Fan over-current cut-out</b> (The fan loads the electronic unit with more than 0.65A <sub>peak</sub> ).
1	<b>Battery protection cut-out</b> (The voltage is outside the cut-out setting).

**Wire Dimensions DC**

Cross section [mm <sup>2</sup> ]	Size AWG [Gauge]	Max. length* 12V operation		Max. length* 24V operation	
		[m]	[ft.]	[m]	[ft.]
2.5	12	2.5	8	5	16
4	12	4	13	8	26
6	10	6	20	12	39
10	8	10	33	20	66

\*Length between battery and electronic unit

**Accessories for BD1.4F-VSD Code number**

Bolt joint for one compressor	Ø:16 mm	118-1917
Bolt joint in quantities	Ø:16 mm	118-1918
Snap-on in quantities	Ø:16 mm	118-1919
Terminal cover for electronic unit		105N9120
Automobile fuse DIN 7258	12V: 15A 24V: 15A	Not deliverable from Secop
Main switch	min. 20A	

**Test conditions EN 12900 CECOMAF ASHRAE LBP**

Condensing temperature	131°F	130°F
Ambient temperature	90°F	90°F
Suction gas temperature	90°F	90°F
Liquid temperature	no subcooling	90°F

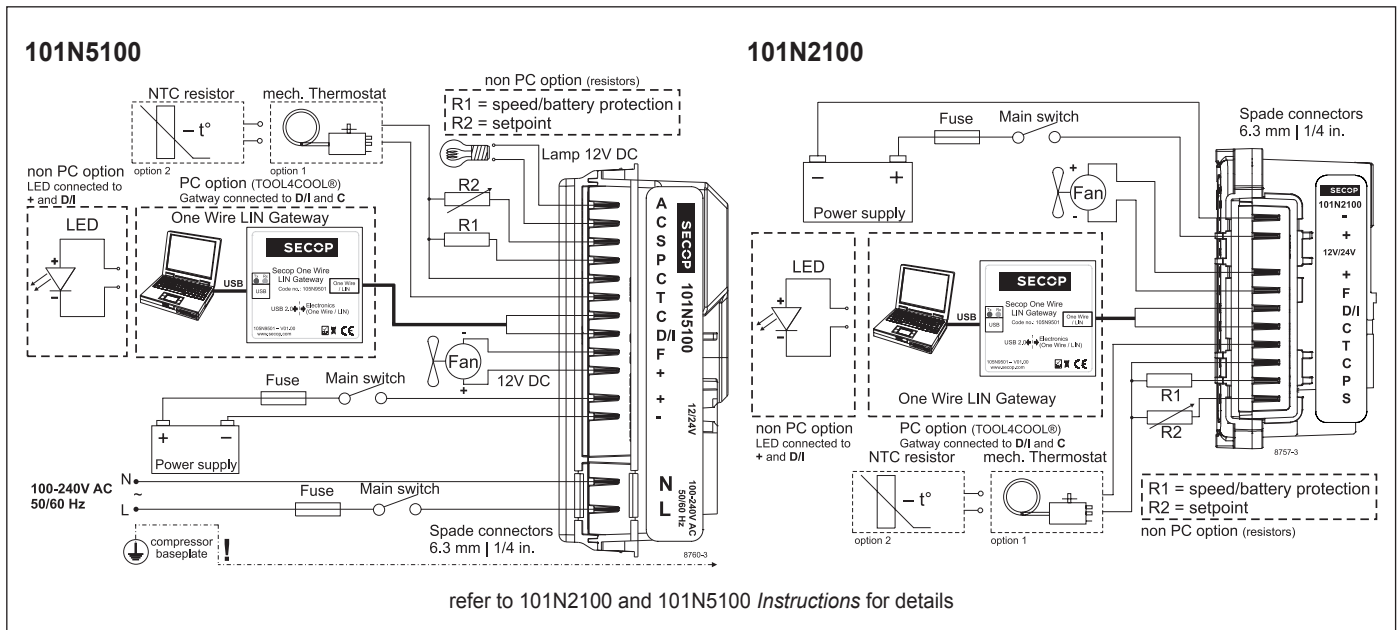

refer to 101N2100 and 101N5100 Instructions for details

Secop accepts no responsibility for possible errors in catalogs, brochures, and other printed material. Secop reserves the right to alter its products without notice. This also applies to products already on order provided that such alterations can be made without substantial changes being necessary to specifications already agreed. All trademarks in this material are the property of the respective companies. Secop and the Secop logotype are trademarks of Secop GmbH. All rights reserved. [www.secop.com](http://www.secop.com)