

## BDN-EV Direct Current Compressor R134a, R1234yf 12V DC

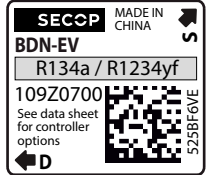

### General

Code number (without electronic unit)	109Z0700
Electronic unit - Automotive Light	101N2830, 40 pcs: 101N2831
Compressors on pallet	240

### Approvals

-
---

### Application

Application range	LBP/MBP
Voltage range	VDC 9.6 - 17

### Cooling requirements

Application	LBP	MBP
32°C / 38°C / 43°C	S	S

### Absolute maximum ratings

Machine compartment temperature for compressor operation	°C	-10 to 55
Max. compressor tilt angle for temporary operation		±30°
Operating pressure range		see diagram to the right

Any levels of stress exceeding the absolute maximum value of machine compartment temperature range or operating pressure range or tilt angle may damage the device. Prolonged exposure to stress above the recommended operating conditions may also affect the device's reliability.

### Motor

Motor type	permanent magnet, brushless DC
Speed	rpm variable speed
Resistance, each of the three windings (25°C)	Ω 0.28

### Design

Displacement	cm <sup>3</sup>	1.42
Oil quantity (type)	cm <sup>3</sup>	53 (polyolester)
Maximum refrigerant charge	g	70
Free gas volume in compressor	cm <sup>3</sup>	472
Weight - Compressor/Electronic unit	kg	1.37 / 0.055

### Standard battery protection settings

Voltage (0.1 steps)			Default	Min. value	Max. value
12V	± 0.3V DC, all values	Cut out level	VDC 9.6	9.6	17
Battery cut-in difference			VDC 1.0	0.5	10

### Dimensions

Height	mm	A	89.0
		B	82.4
		B1	48.7
		B2	45.8
Suction connector	location/I.D. mm   angle	C	6.2   5°
	material   comment		Copper   Rubber plug
Process connector	location/I.D. mm   angle	D	6.2   77.9°
	material   comment		Copper   Rubber plug
Discharge connector	location/I.D. mm   angle	E	5.0   86.9°
	material   comment		Cu-plated steel   Rubber plug
Connector tolerance	I.D. mm		±0.09, on 5.0 +0.12/+0.20

### Remarks:

Please follow the brazing instructions on page 4 (Product Bulletin DES.N.101.M).

S = Static cooling normally sufficient  
**Note:** In case fan cooling is used:  
 condenser => fan => electronic => compressor

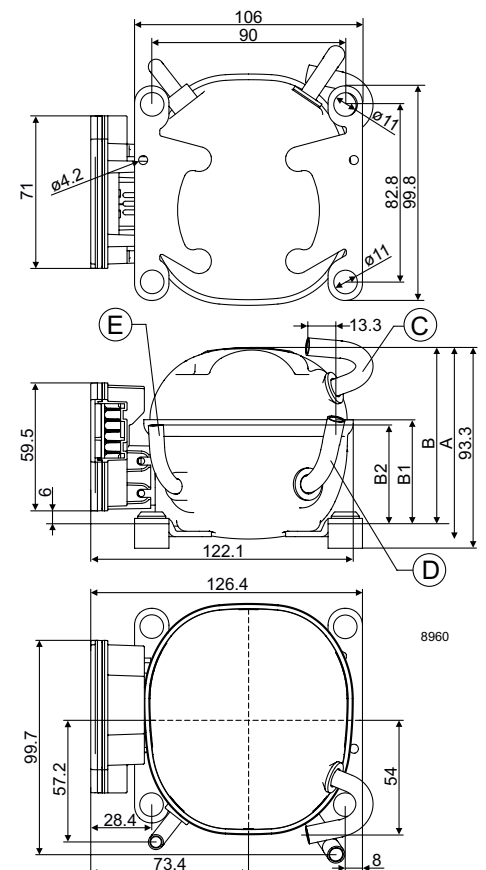
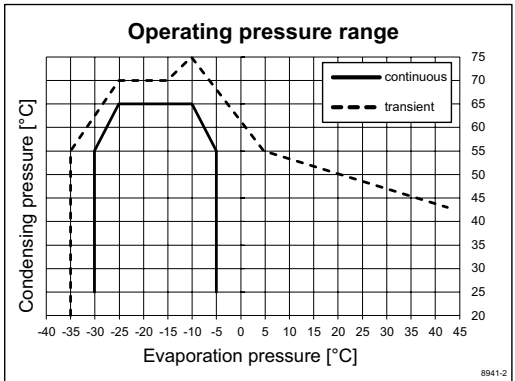

# Performance Data with Refrigerant R134a

**Capacity (EN 12900 Household/CECOMAF)** 12V DC, static cooling **watt**

rpm \ °C	-30	-25	-23.3	-20	-15	-10	-5
2,300	14.3	19.9	22.2	27.1	36.0	47.0	60.1
2,500	14.8	20.8	23.2	28.5	38.1	49.6	63.3
3,000	18.5	26.2	29.4	36.4	49.0	64.0	81.5

**Capacity (ASHRAE LBP)** 12V DC, static cooling **watt**

rpm \ °C	-30	-25	-23.3	-20	-15	-10	-5
2,300	17.9	24.9	27.6	33.7	44.8	58.4	74.7
2,500	18.6	26.0	29.0	35.5	47.4	61.7	78.7
3,000	23.1	32.7	36.6	45.2	60.8	79.5	101.3

**Power consumption** 12V DC, static cooling **watt**

rpm \ °C	-30	-25	-23.3	-20	-15	-10	-5
2,300	15.9	19.0	20.2	22.6	26.4	30.6	35.1
2,500	16.8	20.2	21.5	24.1	28.3	32.8	37.4
3,000	19.2	23.2	24.7	27.9	32.9	38.2	43.4

**Current consumption (for 24V applications the following must be halved)** **A**

rpm \ °C	-30	-25	-23.3	-20	-15	-10	-5
2,300	1.41	1.70	1.81	2.03	2.39	2.78	3.19
2,500	1.47	1.78	1.89	2.13	2.51	2.92	3.34
3,000	1.62	1.97	2.10	2.38	2.82	3.27	3.73

**COP (EN 12900 Household/CECOMAF)** 12V DC, static cooling **W/W**

rpm \ °C	-30	-25	-23.3	-20	-15	-10	-5
2,300	0.90	1.05	1.10	1.20	1.36	1.52	1.70
2,500	0.88	1.03	1.08	1.18	1.34	1.51	1.68
3,000	0.96	1.13	1.18	1.30	1.48	1.67	1.87

**COP (ASHRAE LBP)** 12V DC, static cooling **W/W**

rpm \ °C	-30	-25	-23.3	-20	-15	-10	-5
2,300	1.12	1.31	1.37	1.50	1.70	1.91	2.13
2,500	1.10	1.28	1.35	1.48	1.67	1.88	2.10
3,000	1.20	1.41	1.48	1.62	1.85	2.08	2.34

Test conditions	EN 12900 CECOMAF	ASHRAE LBP
Condensing temperature	55°C	54.4°C
Ambient temperature	32°C	32°C
Suction gas temperature	32°C	32°C
Liquid temperature	no subcooling	32°C

**Operational errors (TOOL4COOL®)**

Error code	Error type
	Can be read out in the software <b>TOOL4COOL®</b>
<b>7</b>	<b>Communication timeout</b> (Communication of master controller stopped for 15 minutes (default))
<b>6</b>	<b>Thermostat failure</b> (If a NTC thermistor is short-circuit or has no connection, the electronic unit will enter manual mode).
<b>5</b>	<b>Thermal cut-out of electronic unit</b> (PCB or machine compartment temperature exceeds minimum or maximum limits).
<b>4</b>	<b>Minimum motor speed error</b> (If the refrigeration system is too heavily loaded, the motor cannot maintain min. speed at approximately 2,150 rpm).
<b>3</b>	<b>Motor start error</b> (The rotor is blocked or the differential pressure in the refrigeration system is too high (>5 bar)).
<b>1</b>	<b>Battery protection cut-out</b> (The voltage is outside the cut-out setting).

## Wire Dimensions DC

Cross section [mm <sup>2</sup> ]	Size AWG [Gauge]	Max. length* 12V operation	
		[m]	[ft.]
2.5	12	2.5	8
4	12	4	13
6	10	6	20
10	8	10	33

\*Length between battery and electronic unit

## Accessories for BDN-EV

Mounting	Code number
Bolt joint for one compressor	118-1960
Bolt joint with nut for one compressor	118-1966
Secop Gateway	105N9518

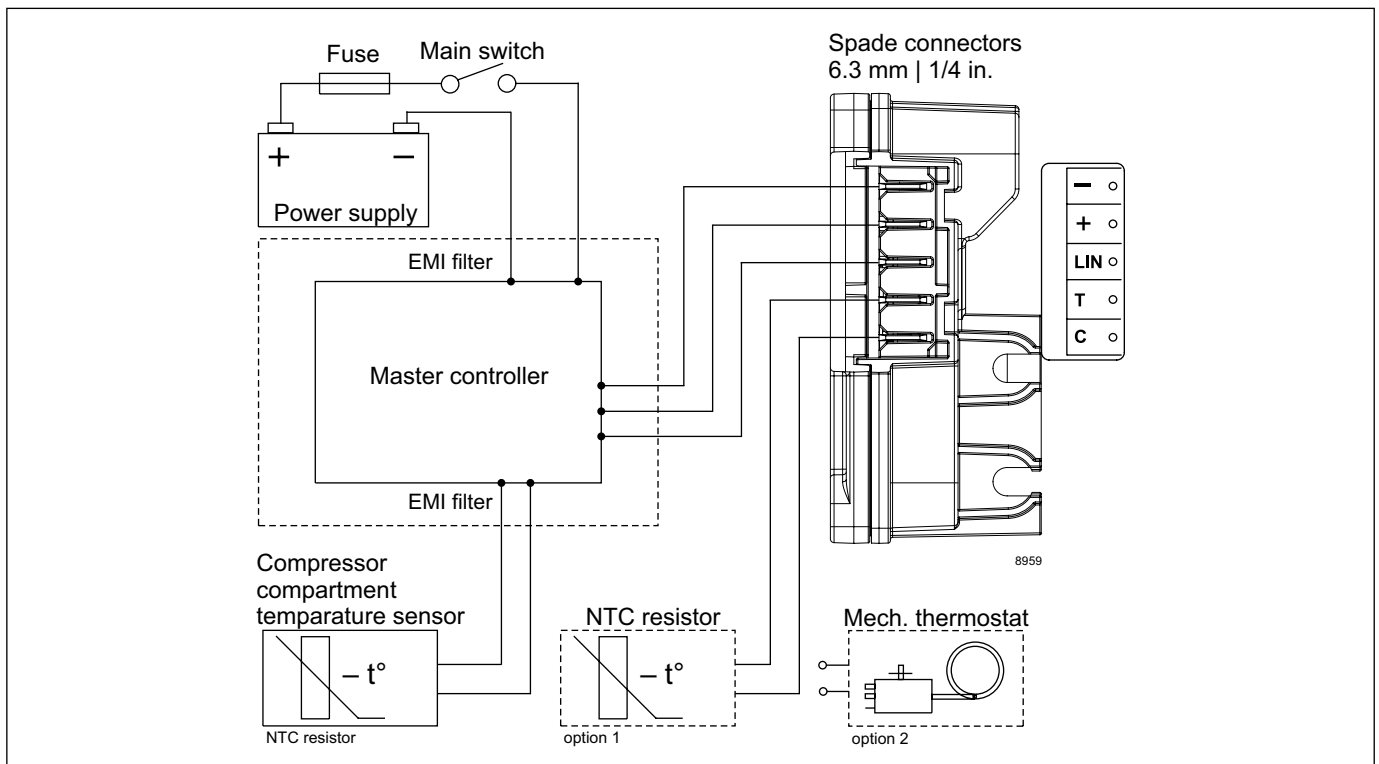

# Performance Data with Refrigerant R1234yf

Capacity (EN 12900 Household/CECOMAF)		12V DC, static cooling						watt
rpm \ °C	-30	-25	-23.3	-20	-15	-10	-5	
2,300	15.8	21.2	23.4	28.1	36.5	46.7	58.8	
2,500	17.1	23.1	25.6	30.8	40.2	51.6	64.8	
3,000	20.4	28.0	31.0	37.7	49.6	63.7	79.8	

Capacity (ASHRAE LBP)		12V DC, static cooling						watt
rpm \ °C	-30	-25	-23.3	-20	-15	-10	-5	
2,300	20.6	27.7	30.5	36.5	47.5	60.7	76.4	
2,500	22.3	30.2	33.3	40.0	52.3	67.0	84.2	
3,000	26.6	36.3	40.3	48.9	64.4	82.6	103.6	

Power consumption		12V DC, static cooling						watt
rpm \ °C	-30	-25	-23.3	-20	-15	-10	-5	
2,300	18.0	20.9	21.9	24.1	27.6	31.5	35.6	
2,500	19.0	22.2	23.3	25.7	29.6	33.7	38.0	
3,000	21.6	25.4	26.9	29.8	34.5	39.3	44.0	

Current consumption (for 24V applications the following must be halved)		12V DC, static cooling						A
rpm \ °C	-30	-25	-23.3	-20	-15	-10	-5	
2,300	1.60	1.86	1.96	2.16	2.50	2.86	3.24	
2,500	1.59	1.85	1.95	2.14	2.46	2.81	3.17	
3,000	1.83	2.16	2.29	2.54	2.95	3.37	3.78	

COP (EN 12900 Household/CECOMAF)		12V DC, static cooling						W/W
rpm \ °C	-30	-25	-23.3	-20	-15	-10	-5	
2,300	0.88	1.02	1.07	1.17	1.32	1.48	1.65	
2,500	0.90	1.04	1.09	1.20	1.35	1.52	1.70	
3,000	0.94	1.10	1.15	1.27	1.44	1.62	1.81	

COP (ASHRAE LBP)		12V DC, static cooling						W/W
rpm \ °C	-30	-25	-23.3	-20	-15	-10	-5	
2,300	1.15	1.33	1.39	1.52	1.72	1.93	2.15	
2,500	1.17	1.36	1.42	1.56	1.77	1.99	2.22	
3,000	1.23	1.43	1.50	1.64	1.87	2.10	2.36	

Test conditions	EN 12900 CECOMAF	ASHRAE LBP
Condensing temperature	55°C	54.4°C
Ambient temperature	32°C	32°C
Suction gas temperature	32°C	32°C
Liquid temperature	no subcooling	32°C

Error code	Error type
	Can be read out in the software <b>TOOL4COOL®</b>
7	<b>Communication timeout</b> (Communication of master controller stopped for 15 minutes (default))
6	<b>Thermostat failure</b> (If a NTC thermistor is short-circuit or has no connection, the electronic unit will enter manual mode).
5	<b>Thermal cut-out of electronic unit</b> (PCB or machine compartment temperature exceeds minimum or maximum limits).
4	<b>Minimum motor speed error</b> (If the refrigeration system is too heavily loaded, the motor cannot maintain min. speed at approximately 2,150 rpm).
3	<b>Motor start error</b> (The rotor is blocked or the differential pressure in the refrigeration system is too high (>5 bar)).
1	<b>Battery protection cut-out</b> (The voltage is outside the cut-out setting).

## Wire Dimensions DC

Size		Max. length* 12V operation	
Cross section [mm <sup>2</sup> ]	AWG [Gauge]	[m]	[ft.]
2.5	12	2.5	8
4	12	4	13
6	10	6	20
10	8	10	33

\*Length between battery and electronic unit

## Accessories for BDN-EV

Mounting	Code number
Bolt joint for one compressor	118-1960
Bolt joint with nut for one compressor	118-1966
Secop Gateway	105N9518

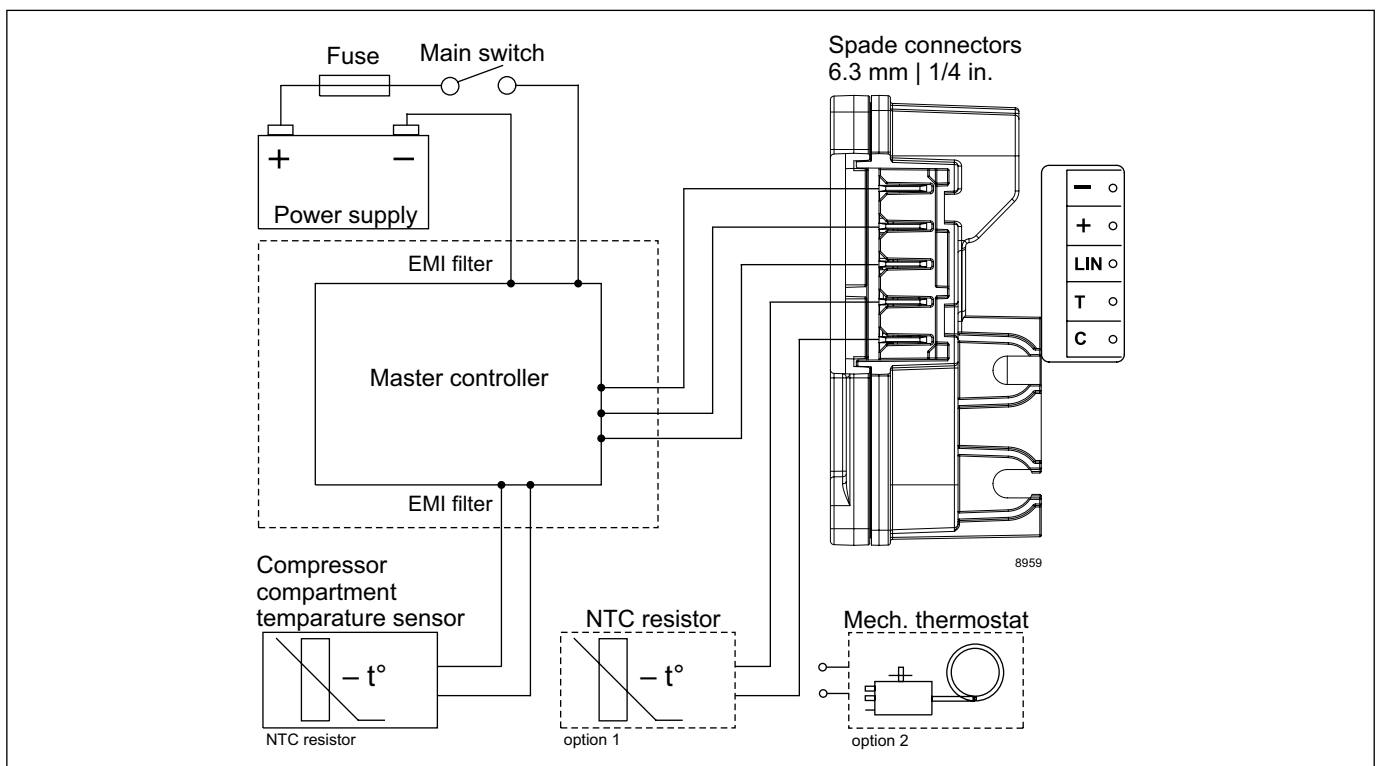

Secop accepts no responsibility for possible errors in catalogs, brochures, and other printed material. Secop reserves the right to alter its products without notice. This also applies to products already on order provided that such alterations can be made without consequential changes being necessary to specifications already agreed. All trademarks in this material are the property of the respective companies. Secop and the Secop logotype are trademarks of Secop GmbH. All rights reserved. [www.secop.com](http://www.secop.com)

## Brazing on BD Nano Discharge Connector (BDN45F, BDN50K, BDN45F-A, BDN50K-A, MB3CKV, and BDN-EV)

Secop BDN45F/-A, BDN50K/-A, MB3CKV, BDN-EV compressors use a special discharge connector element (see figure 2) that is directly connected to the discharge tube to optimize energy consumption. This element is made from plastic and sensitive to high heat exposure.

When brazing a tube into the discharge connector (see figure 1) please ensure that the area with the discharge connector element never exceeds 150°C / 302°F. Don't heat up the bottom of the connector directly.

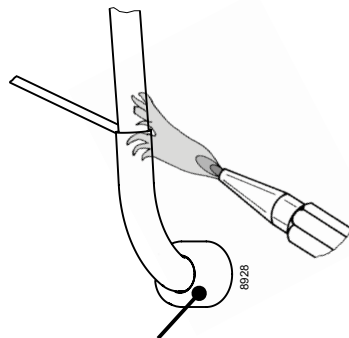

**! max. 150°C/302°F !**  
**at socket**  
brazing solder: silver with flux

Use a fork burner (see figure 3) and/or a damp cloth, if necessary. A protective plate can also serve to protect the discharge connector element from direct heat from a flame. Do not braze longer than 10 seconds and wait for 5 minutes for the next soldering attempt.

### Further information:

Product Bulletin – Brazing Technique for Compressor Connectors (DES.N.600.A1.02)



Fig.1 BDN45F discharge connector

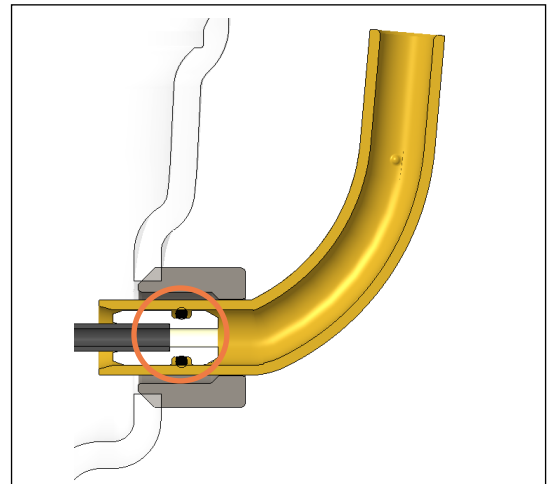

Fig.2 Discharge connector element

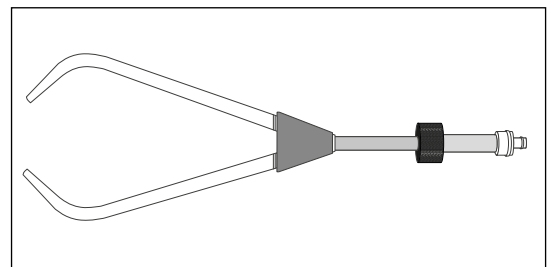

Fig.3 Fork burner