

## Model

Designation	<b>GS21MLX</b>	187-254V/60Hz 1~	Sales code:	<b>107B0509</b>
-------------	----------------	------------------	-------------	-----------------

## Compressor design

Oil type	Polyolester	Refrigerant(s)	<b>R404A, R507, R452A</b>
Oil viscosity	32,5cST	Displacement	21,2cm <sup>3</sup> / 1,29cu.in
Oil quantity	902cm <sup>3</sup> / 30,5fl.oz	Compressors on pallet	48
Refr. charge - tech. limit	2000g / 70,5oz		
Free gas volume comp.	3540cm <sup>3</sup> / 119,7fl.oz		
Weight	22,2kg / 48,9lbs		
Motor protection	1# internal		
Winding resistance main	1,5Ω (at 25°C)		
Winding resistance aux	5,8Ω (at 25°C)		
Max. winding temp.			
Max. discharge temp.	130°C / 266°F		



## General - Configurations with GS21MLX

	<b>Conf. 1</b>	<b>Conf. 2</b>
Motorconfiguration	CSCR	CSCR
Power supply (nominal)	208-230V/60Hz	208-230V/60Hz
Number of phases	1	1
Voltage range	187-254V	187-254V
Approvals	UL	UL
Starting torque	HST	HST
Note	Cover, clamp, gasket: pre-assembled to compressor.	

## Applications with GS21MLX

	<b>Conf. 1</b>	<b>Conf. 2</b>
Refrigerant	R404A	R452A
Application	MBP	MBP
System cooling	fan 3m/s	fan 3m/s
Hot gas defrost	OK	OK
Long interval pull down	OK	OK

## Electrical data - Configurations with GS21MLX

	<b>Conf. 1</b>	<b>Conf. 2</b>
Starting device type	relay	relay
Run capacitor	20μF	20μF
Start capacitor	100μF	100μF
LRA (locked rotor amps / 4s)	46A	46A
RLA (rated load amps / 1s)	11A	11A
Cut in current	46A	46A

## Model

Designation

**GS21MLX**

187-254V/60Hz 1~

Sales code:

**107B0509**

## Compressor dimensions

Housing	A Height	279mm / 10,98in
	B Height	267mm / 10,51in
	C Length shell	224mm / 8,82in
	D Length w. cover	232mm / 9,13in
	E Width	173mm / 6,81in

Connectors	Suction	Discharge	Process
	X	Y	Z
Diameter [mm]	øi 12,75-13,05	øi 9,63-9,73	øi 6,4-6,6
(i:inside, o:outside) [in]	øi 0,5-0,51	øi 0,38-0,38	øi 0,25-0,26
Material	copper	copper	copper
Horizontal angle ±2°	0°	0°	0°
Vertical angle ±2°	90°	71°	90°
Position l/h/w [mm]	-95/234/-84	-105/84/-84	95/234/84
[in]	-3,7/9,2/-3,3	-4,1/3,3/-3,3	3,7/9,2/3,3
Straight tube l. [mm]	18	23	15
[in]	0,7	0,9	0,6

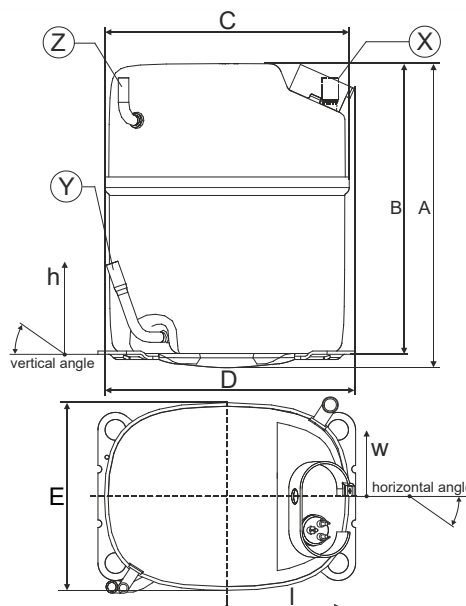

## Compressor fixation

### Bolt joint

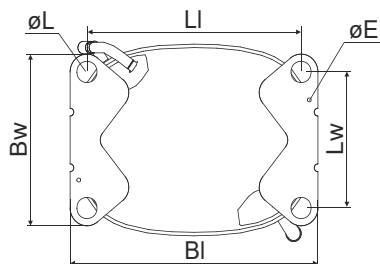

Baseplate	[mm]	[inch]
BI	235	9.25
Bw	154	6.06
øE	ø 3.6	ø 0.14

Large holes	[mm]	[inch]
LI	203	7.99
Lw	122	4.80
øL	ø 19	ø 0.75

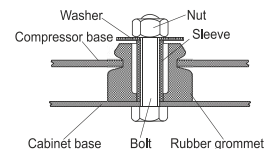

## Mounting accessories

Bolt joint | M8 | ø19mm

one comp.

107B9150

## Model

Designation	<b>GS21MLX</b>	<b>208-230V/60Hz</b>	Conf. 1	Sales code:	<b>107B0509</b>
-------------	----------------	----------------------	---------	-------------	-----------------

## Configuration

Motorconfiguration	CSCR
Power supply (nominal)	208-230V/60Hz 1~
Refrigerant	R404A
Application	MBP
Voltage range	187-254V
Starting torque	HST
Approvals	UL

## Electrical accessories / wiring diagram

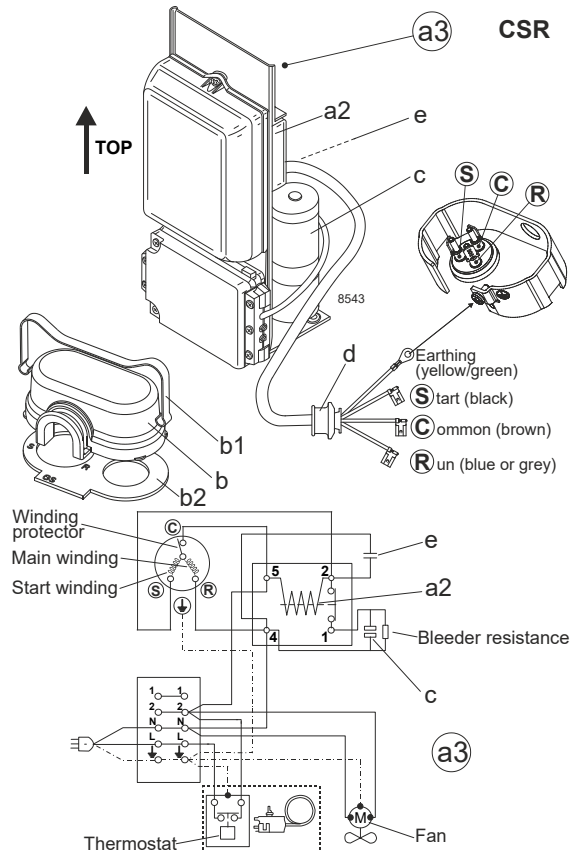

## Ambient/ machine room temperatures minimum /maximum

Ambient temperature range:	10 - 43°C / 50 - 110°F
Machine room temperature range:	10 - 48°C / 50 - 119°F
Compressor cooling:	fan 3m/s

## Operation Limits

## Operation pressure range

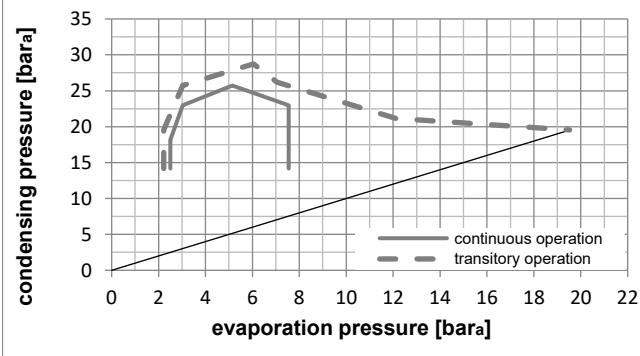
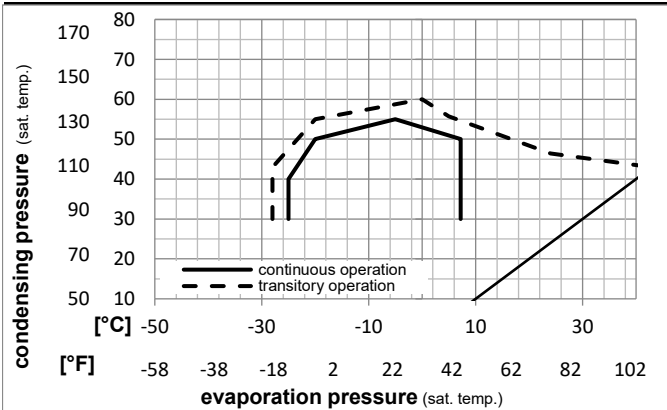

## Components (cover, clamp, gasket: pre assembled)

a3	GS starter kit (600mm)	117-7073
b	cover	107B9101
b2	gasket	107B9100
b1	clamp	107B9104

### Model

Designation **GS21MLX 208-230V/60Hz** Conf. 1 Sales code: **107B0509**

### Optimization + standard conditions

R404A, 230V/60Hz, CSCR, fan 3m/s, UL

		Evaporating pressure (saturation temperature)				Condensing pressure (saturation temperature)			Return gas temp.			Liquid temp.			Cooling capacity			COP	EER	Power consumption			
		pe	pc	RGT	Tliq	[W]	[Btu/h]	[kcal/h]	[W/W]	[Btu/Wh]	[kcal/Wh]	P1	I	Ref. mass flow	m								
[°C]	[°F]											[W]	[A]	[kg/h]									
-7	20,012	54	35	46	2515,2	8590	2164,6	1,86	6,34	1,60	1354,2	6,22	69,21	ASHRAE MBP									
-10	14	55	32	55	1872,8	6396	1611,7	1,47	5,01	1,26	1276,9	5,90	59,95	cecomaf MBP									
-10	14	45	20	45	2268,1	7746	1951,9	1,93	6,57	1,66	1178,2	5,48	68,32	EN12900 MBP									
-7	20,012	49	18	49	2334,9	7974	2009,5	1,81	6,19	1,56	1287,7	5,95	76,30	ARI540 MBP									
-10	14	45	32	45	2407,1	8221	2071,6	2,04	6,98	1,76	1178,2	5,48	66,29	opt									
-25	-13	45	32	45	1180,9	4033	1016,3	1,36	4,64	1,17	868,7	4,15	31,85	opt									

### Performance tables

R404A, 230V/60Hz, CSCR, fan 3m/s, UL

	pe		Cooling capacity			COP	EER	P1	I	m	
	[°C]	[°F]	[W]	[Btu/h]	[kcal/h]	[W/W]	[Btu/Wh]	[kcal/Wh]	[W]	[A]	[kg/h]
[°C / °F]	-25	-13	1180,9	4033	1016,3	1,36	4,64	1,17	868,7	4,15	31,85
cond. pressure	-23	-10	1293,2	4417	1113,0	1,43	4,88	1,23	904,6	4,31	34,95
pc= 45/113	-15	5	1938,5	6620	1668,3	1,80	6,14	1,55	1077,8	5,05	52,95
return gas temp.	-9	15	2463,5	8413	2120,1	2,07	7,07	1,78	1189,2	5,52	67,91
RGT= 32/90	-4	25	3081,8	10525	2652,2	2,37	8,10	2,04	1298,8	5,98	85,87
liquid temp	0	32	3578,0	12219	3079,2	2,60	8,89	2,24	1375,0	6,29	100,59
Tliq= 45/113	7,2	45	4657,4	15906	4008,2	3,07	10,48	2,64	1517,4	6,84	133,56
[°C / °F]	-25	-13	899,6	3072	774,2	1,03	3,53	0,89	870,9	4,27	28,12
cond. pressure	-23	-10	991,3	3385	853,1	1,08	3,69	0,93	918,6	4,46	31,05
pc= 55/131	-15	5	1505,4	5141	1295,6	1,31	4,48	1,13	1147,1	5,37	47,74
return gas temp	-9	15	1916,9	6547	1649,7	1,48	5,07	1,28	1291,0	5,96	61,44
RGT= 32/90	-4	25	2400,8	8199	2066,2	1,68	5,73	1,45	1429,8	6,52	77,92
liquid temp	0	32	2790,6	9530	2401,6	1,83	6,25	1,58	1524,6	6,90	91,51
Tliq= 55/131	7,2	45	3645,3	12449	3137,2	2,15	7,34	1,85	1696,9	7,59	122,35

## Model

Designation

**GS21MLX**

**208-230V/60Hz**

Conf. 2

Sales code:

**107B0509**

## Configuration

Motorconfiguration	CSCR
Power supply (nominal)	208-230V/60Hz 1~
Refrigerant	R452A
Application	MBP
Voltage range	187-254V
Starting torque	HST
Approvals	UL

## Electrical accessories / wiring diagram

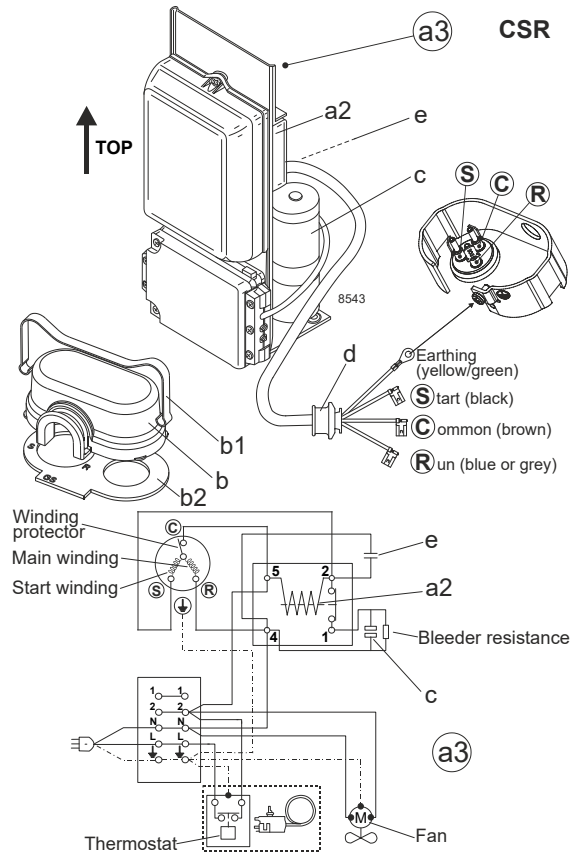

## Ambient/ machine room temperatures minimum /maximum

Ambient temperature range: 10 - 43°C / 50 - 110°F

Machine room temperature range: 10 - 48°C / 50 - 119°F

Compressor cooling: fan 3m/s

## Operation Limits

### Operation pressure range

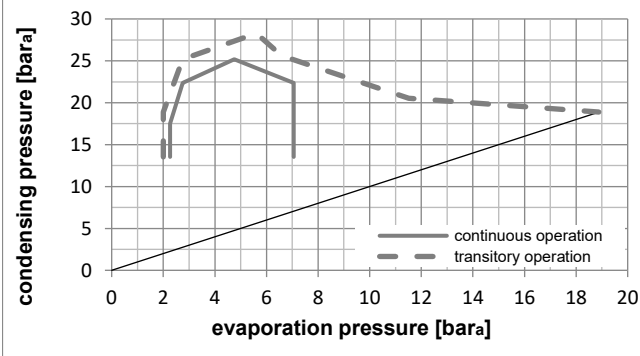
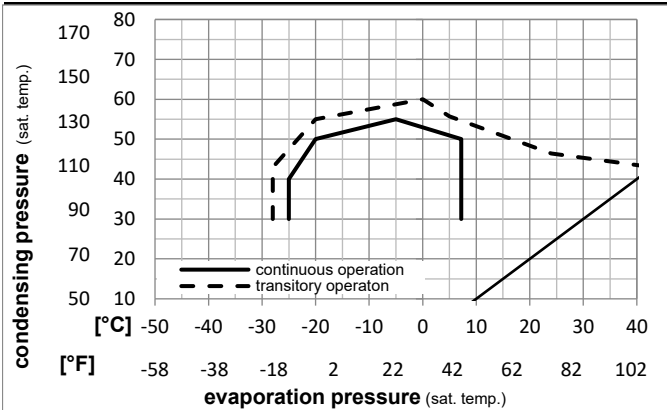

### Components (cover, clamp, gasket: pre assembled)

a3	GS starter kit (600mm)	117-7073
b	cover	107B9101
b2	gasket	107B9100
b1	clamp	107B9104

### Model

Designation **GS21MLX 208-230V/60Hz** Conf. 2 Sales code: **107B0509**

### Optimization + standard conditions

R452A, 230V/60Hz, CSCR, fan 3m/s, UL

		Evaporating pressure (saturation temperature)				Condensing pressure (saturation temperature)						Power consumption			
		Return gas temp.		Liquid temp.		Cooling capacity		COP	EER		Current consumption		Ref. mass flow		
pe	pc	RGT	Tliq	[W]	[Btu/h]	[kcal/h]	[W/W]	[Btu/Wh]	[kcal/Wh]	P1	I	m			
[°C]	[°F]	[°C]	[°F]	[W]	[Btu/h]	[kcal/h]	[W/W]	[Btu/Wh]	[kcal/Wh]	[W]	[A]	[kg/h]			
-7	54	35	46	2381,7	8134	2049,7	1,86	6,36	1,60	1279,7	5,91	67,00	ASHRAE MBP		
20,012	130	95	115												
-10	55	32	55	1776,3	6066	1528,7	1,48	5,05	1,27	1201,3	5,59	57,73	cecomaf MBP		
14	131	90	131												
-10	45	20	45	2142,9	7318	1844,2	1,93	6,59	1,66	1110,8	5,22	65,84	EN12900 MBP		
14	113	68	113												
-7	49	18	49	2221,5	7587	1911,9	1,82	6,23	1,57	1218,2	5,66	73,70	ARI540 MBP		
20,012	120	65	120												
-10	45	32	45	2270,8	7755	1954,2	2,04	6,98	1,76	1110,8	5,22	63,98	opt		
14	113	90	113												
-25	45	32	45	1087,8	3715	936,1	1,35	4,62	1,16	803,8	3,96	30,09	opt		
-13	113	90	113												

### Performance tables

R452A, 230V/60Hz, CSCR, fan 3m/s, UL

	pe		Cooling capacity			COP	EER	P1	I	m	
	[°C]	[°F]	[W]	[Btu/h]	[kcal/h]	[W/W]	[Btu/Wh]	[kcal/Wh]	[W]	[A]	[kg/h]
[°C / °F]	-25	-13	1087,8	3715	936,1	1,35	4,62	1,16	803,8	3,96	30,09
cond. pressure	-23	-10	1195,1	4082	1028,6	1,42	4,86	1,23	839,0	4,11	33,11
pc= 45/113	-15	5	1816,2	6203	1563,1	1,80	6,14	1,55	1010,3	4,81	50,81
return gas temp.	-9	15	2325,7	7943	2001,5	2,07	7,08	1,78	1121,9	5,27	65,58
RGT= 32/90	-4	25	2928,8	10002	2520,6	2,38	8,11	2,04	1233,1	5,72	83,40
liquid temp	0	32	3414,8	11662	2938,8	2,60	8,89	2,24	1311,5	6,04	98,01
Tliq= 45/113	7,2	45	4476,3	15287	3852,3	3,07	10,47	2,64	1460,4	6,65	130,78
[°C / °F]	-25	-13	828,9	2831	713,3	1,03	3,53	0,89	802,1	3,96	26,38
cond. pressure	-23	-10	917,2	3132	789,4	1,08	3,69	0,93	848,5	4,15	29,24
pc= 55/131	-15	5	1416,3	4837	1218,9	1,32	4,51	1,14	1072,2	5,06	45,65
return gas temp	-9	15	1819,7	6215	1566,0	1,50	5,11	1,29	1215,5	5,65	59,20
RGT= 32/90	-4	25	2297,0	7845	1976,8	1,69	5,79	1,46	1355,8	6,23	75,57
liquid temp	0	32	2683,2	9164	2309,2	1,85	6,31	1,59	1453,1	6,62	89,09
Tliq= 55/131	7,2	45	3533,4	12067	3040,9	2,16	7,39	1,86	1633,8	7,37	119,76