

## Model

Designation	<b>HXK12AT</b>	<b>200-240V/50Hz 1~ 208-230V/60Hz 1~</b>	Sales code:	<b>16470500</b>
-------------	----------------	--	-------------	-----------------

## Compressor design

Oil type	Mineral	Refrigerant(s)	<b>R600a</b>
Oil viscosity	5cSt	Displacement	11,1cm <sup>3</sup> / 0,68cu.in
Oil quantity	162cm <sup>3</sup> / 5,5fl.oz	Compressors on pallet	100
Refr. charge - tech. limit	150g / 5,3oz		
Free gas volume comp.	1560cm <sup>3</sup> / 52,7fl.oz		
Weight	8,9kg / 19,6lbs		
Motor protection	external		
Winding resistance main	12,4Ω (at 25°C)		
Winding resistance aux	15,3Ω (at 25°C)		
Max. winding temp.	130°C / 266°F		
Max. discharge temp.	130°C / 266°F		



## General - Configurations with HXK12AT

	<b>Conf. 1</b>	<b>Conf. 2</b>	<b>Conf. 3</b>
Motor configuration	RSIR	RSCR	RSCR
Power supply (nominal)	200-240V/50Hz	200-240V/50Hz	208-230V/60Hz
Number of phases	1	1	1
Voltage range	170-264V	170-264V	198-253V
Approvals	VDE	VDE	VDE
Starting torque	LST	LST	LST
Note	Various options of connectors are possible - please contact SECOP-Sales.		

## Applications with HXK12AT

	<b>Conf. 1</b>	<b>Conf. 2</b>	<b>Conf. 3</b>
Refrigerant	R600a	R600a	R600a
Application	LBP	LBP	LBP
System cooling	static	static	static
Hot gas defrost	-/-	-/-	-/-
Long interval pull down	-/-	-/-	-/-

## Electrical data - Configurations with HXK12AT

	<b>Conf. 1</b>	<b>Conf. 2</b>	<b>Conf. 3</b>
Starting device type	PTC	PTC	PTC
Run capacitor	-/-	4μF	4μF
Start capacitor	-/-	-/-	-/-
LRA (locked rotor amps / 4s/ U(N))		7,3A	
RLA (rated load amps / 1s/ U(N))	-/-A	0,6A	
Cut in current (U(N))		11,1A	

## Model

Designation **HXK12AT** 200-240V/50Hz 1~ 208-230V/60Hz 1~ Sales code: **16470500**

## Compressor dimensions

<b>Housing</b>	A Height	174mm / 6,85in
	B Height	167mm / 6,57in
	C Length shell	194mm / 7,64in
	D Length w. cover	238mm / 9,37in
	E Width	151mm / 5,94in

Connectors		Suction	Discharge	Process
		X	Y	Z
Diameter	[mm]	øi 6,1-6,2	øi 5,1-5,2	øo 5,92-6,08
(i:inside, o:outside)	[in]	øi 0,24-0,24	øi 0,2-0,2	øo 0,23-0,24
Material		copper	copper	copper
Horizontal angle	±2°	45°	13°	0°
Vertical angle	±2°	30°	40°	145°
Position l/h/w	[mm]	120/72/62	112/106/62	-140/136/70
	[in]	4,7/2,8/2,4	4,4/4,2/2,4	-5,5/5,4/2,8
Straight tube l.	[mm]	14	14	75
	[in]	0,5	0,5	3

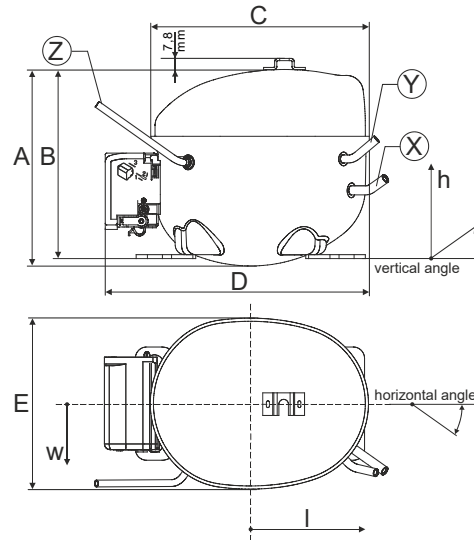

## Compressor fixation

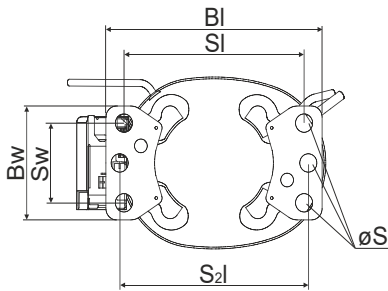

Baseplate	[mm]	[inch]
BI	204	8.03
Bw	100	3.94
Small holes		
	[mm]	[inch]
SI	170	6.7
Sw	70	2.76
S2l	178	7
øS	ø 16	ø 0.63

## Bolt joint

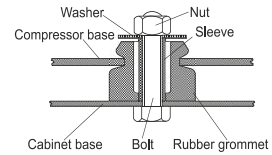

## Snap-on

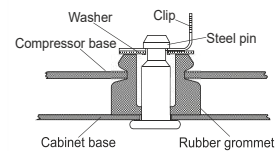

## Mounting accessories

- '4ZN' with rubber grommet
- '4ZN' with rubber grommet and sleeve for M6
- Bolt joint kit
- '4ZN' with Snap on kit

- order code
- 772N
  - 768N
  - 4ZN + 118-1917 (18)
  - 776N

## Application notes

Provision for PE Grounding is located at the PE Stamp on the compressor Housing with dip-tray fixture (omega bracket).  
Various options of connectors are possible - please contact SECOP-Sales.

## Model

Designation **HXK12AT** **200-240V/50Hz** Conf. 1 Sales code: **16470500**

## Configuration

Motor configuration RSIR  
 Power supply (nominal) 200-240V/50Hz 1~  
 Refrigerant R600a  
 Application LBP  
 Voltage range 170-264V  
 Starting torque LST  
 Approvals VDE

## Electrical accessories / wiring diagram

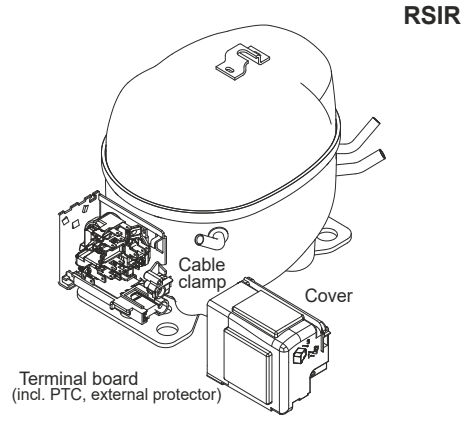

## Ambient/ machine room temperatures minimum /maximum

Ambient temperature range: 10 - 43°C / 50 - 110°F  
 Machine room temperature range: 10 - 48°C / 50 - 119°F  
 Compressor cooling: static

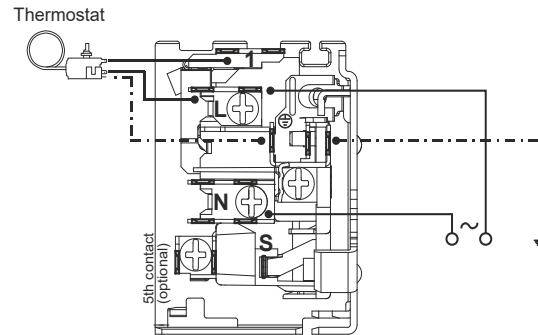

## Operation pressure range

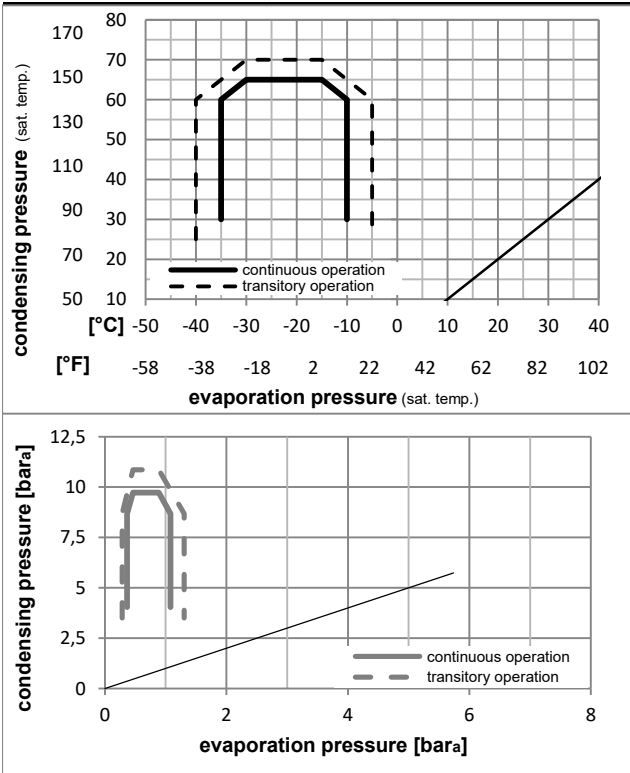

## Components

- . terminal board (PTC, 4.8mm) 16425900
- b cover terminal board 10636401
- . cable clamp 16058100
- . screw - uni6954 10636000
- . screw - uni6954 10636200
- . screw uni en iso 4757 10641201

## Alternative components

- . terminal board (PTC, 6.3mm) 16425700

## Model

Designation **HXK12AT** **200-240V/50Hz** Conf. 1 Sales code: **16470500**

## Optimization + standard conditions

R600a, 200V/50Hz, RSIR, static, VDE

	Evaporating pressure (saturation temperature)				Condensing pressure (saturation temperature)			Return gas temp.			Liquid temp.			Cooling capacity			COP	EER	Power consumption			
	pe	pc	RGT	Tliq	[W]	[Btu/h]	[kcal/h]	[W/W]	[Btu/Wh]	[kcal/Wh]	[W]	I	m	[A]	[kg/h]							
[°C]	-23	54	32	32	198,1	677	170,5	1,67	5,70	1,44	118,7	0,63	2,13									
[°F]	-10	130	90	90																		
	-25	55	32	55	149,8	511	128,9	1,30	4,43	1,12	115,4	0,61	1,95								ASHRAE LBP	
	-13	131	90	131																		cecomaf LBP
	-35	40	20	40	113,6	388	97,8	1,20	4,10	1,03	94,6	0,55	1,38									EN12900 LBP
	-31	104	68	104																		
	-23	49	4,4	49	160,1	547	137,8	1,40	4,80	1,21	114,0	0,61	2,34									ARI540 LBP
	-10	120	40	120																		
	-23	41	32	32	208,0	710	179,0	1,93	6,59	1,66	107,7	0,60	2,23									AHAM LBP
	-10	105	90	90																		
	-35	45	32	45	110,5	377	95,1	1,13	3,87	0,98	97,5	0,55	1,31									opt
	-31	113	90	113																		

## Performance tables

R600a, 200V/50Hz, RSIR, static, VDE

	pe		Cooling capacity			COP	EER		P1	I	m
	[°C]	[°F]	[W]	[Btu/h]	[kcal/h]	[W/W]	[Btu/Wh]	[kcal/Wh]	[W]	[A]	[kg/h]
[°C / °F]	-35	-31	110,5	377	95,1	1,13	3,87	0,98	97,5	0,55	1,31
cond. pressure	-30	-22	135,5	463	116,6	1,35	4,61	1,16	100,5	0,56	1,61
pc= 45/113	-25	-13	171,1	584	147,2	1,59	5,43	1,37	107,6	0,59	2,04
return gas temp.	-23	-10	185,6	634	159,7	1,67	5,72	1,44	110,9	0,61	2,21
RGT= 32/90	-20	-4	217,2	742	187,0	1,83	6,26	1,58	118,5	0,64	2,59
liquid temp	-15	5	273,9	936	235,8	2,06	7,05	1,78	132,7	0,70	3,27
Tliq= 45/113	-10	14	341,2	1165	293,7	2,28	7,77	1,96	149,9	0,77	4,09
[°C / °F]	-35	-31	94,1	321	81,0	0,91	3,12	0,79	102,9	0,57	1,22
cond. pressure	-30	-22	117,4	401	101,0	1,10	3,75	0,94	107,0	0,58	1,53
pc= 55/131	-25	-13	149,8	511	128,9	1,30	4,43	1,12	115,4	0,61	1,95
return gas temp	-23	-10	162,8	556	140,1	1,37	4,66	1,18	119,2	0,63	2,13
RGT= 32/90	-20	-4	191,2	653	164,6	1,50	5,11	1,29	127,8	0,66	2,50
liquid temp	-15	5	241,8	826	208,1	1,68	5,74	1,45	143,7	0,73	3,17
Tliq= 55/131	-10	14	301,4	1029	259,4	1,85	6,32	1,59	162,9	0,82	3,96

## Model

Designation **HXK12AT** **200-240V/50Hz** Conf. 2 Sales code: **16470500**

## Configuration

Motor configuration RSCR  
 Power supply (nominal) 200-240V/50Hz 1~  
 Refrigerant R600a  
 Application LBP  
 Voltage range 170-264V  
 Starting torque LST  
 Approvals VDE

## Electrical accessories / wiring diagram

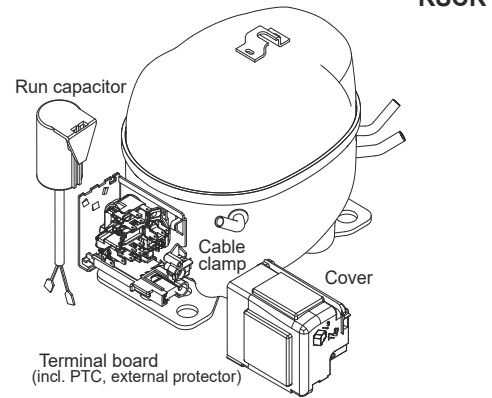

## Ambient/ machine room temperatures minimum /maximum

Ambient temperature range: 10 - 43°C / 50 - 110°F  
 Machine room temperature range: 10 - 48°C / 50 - 119°F  
 Compressor cooling: static

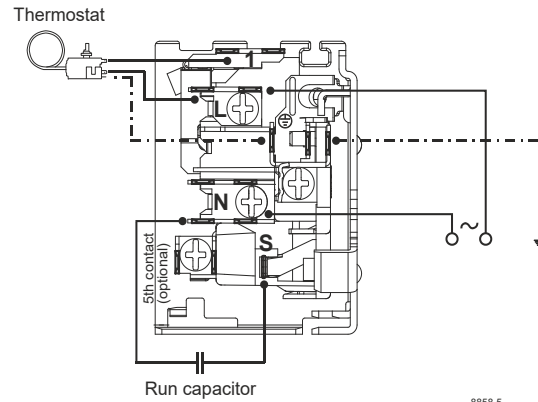

## Operation pressure range

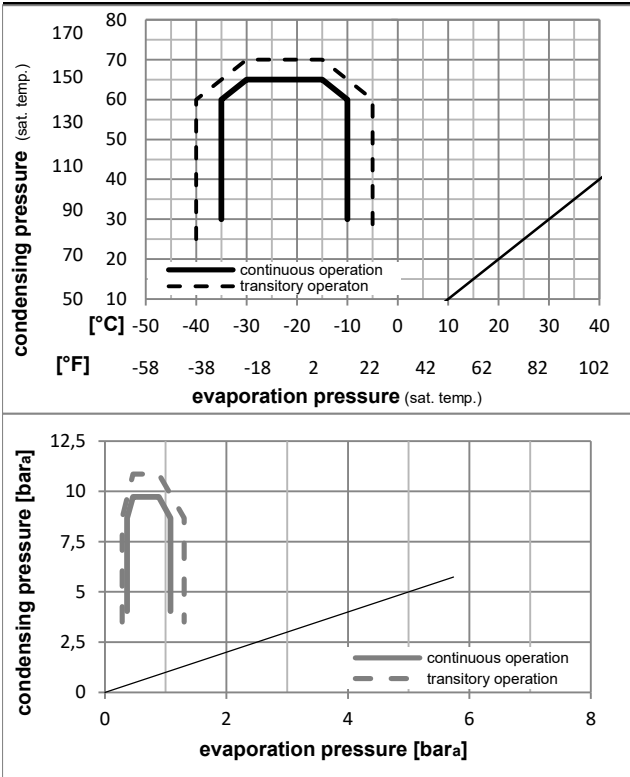

## Components

- . terminal board (PTC, 4.8mm) 16425900
- . run capacitor (4μF, 4.8mm) 10693001
- b cover terminal board 10636401
- . cable clamp 16058100
- . screw - uni6954 10636000
- . screw - uni6954 10636200

## Alternative components

- . terminal board (PTC, 6.3mm) 16425700
- . run capacitor (4μF, 4.8mm) 16344500
- . run capacitor (4μF, 6.3mm) 15186801
- . screw uni en iso 4757 10641201

## Model

Designation **HXK12AT** **200-240V/50Hz** Conf. 2 Sales code: **16470500**

## Optimization + standard conditions

R600a, 200V/50Hz, RSCR, static, VDE

		Evaporating pressure (saturation temperature)				Condensing pressure (saturation temperature)			Return gas temp.		Liquid temp.		Cooling capacity			COP	EER	Power consumption		
		pe	pc	RGT	Tliq	[W]	[Btu/h]	[kcal/h]	[W/W]	[Btu/Wh]	[kcal/Wh]	[W]	I	m	[W]	[A]	[kg/h]			
[°C]	[°F]	[°C]	[°F]	[°C]	[°F]													ASHRAE LBP		
-23	-10	54	130	32	90	200,1	683	172,2	1,73	5,92	1,49	115,5	0,60	2,15				ASHRAE LBP		
-25	-13	55	131	32	90	151,3	517	130,2	1,35	4,60	1,16	112,3	0,59	1,97				cecomaf LBP		
-35	-31	40	104	20	68	114,8	392	98,8	1,25	4,26	1,07	92,1	0,53	1,40				EN12900 LBP		
-23	-10	49	120	4,4	40	161,7	552	139,2	1,46	4,98	1,25	110,9	0,59	2,36				ARI540 LBP		
-23	-10	41	105	32	90	210,1	717	180,8	2,00	6,84	1,72	104,8	0,57	2,25				AHAM LBP		
-35	-31	45	113	32	90	111,6	381	96,1	1,18	4,02	1,01	94,8	0,53	1,33				opt		

## Performance tables

R600a, 200V/50Hz, RSCR, static, VDE

	pe		Cooling capacity			COP	EER		P1	I	m
	[°C]	[°F]	[W]	[Btu/h]	[kcal/h]	[W/W]	[Btu/Wh]	[kcal/Wh]	[W]	[A]	[kg/h]
[°C / °F]	-35	-31	111,6	381	96,1	1,18	4,02	1,01	94,8	0,53	1,33
cond. pressure	-30	-22	136,9	467	117,8	1,40	4,78	1,21	97,7	0,54	1,63
pc= 45/113	-25	-13	172,8	590	148,7	1,65	5,64	1,42	104,7	0,57	2,06
return gas temp.	-23	-10	187,5	640	161,3	1,74	5,93	1,50	107,9	0,58	2,23
RGT= 32/90	-20	-4	219,4	749	188,8	1,90	6,50	1,64	115,3	0,61	2,62
liquid temp	-15	5	276,7	945	238,1	2,14	7,32	1,84	129,1	0,67	3,31
Tliq= 45/113	-10	14	344,6	1177	296,6	2,36	8,07	2,03	145,9	0,74	4,13
[°C / °F]	-35	-31	95,0	325	81,8	0,95	3,24	0,82	100,2	0,55	1,24
cond. pressure	-30	-22	118,6	405	102,0	1,14	3,89	0,98	104,1	0,56	1,54
pc= 55/131	-25	-13	151,3	517	130,2	1,35	4,60	1,16	112,3	0,59	1,97
return gas temp	-23	-10	164,5	562	141,5	1,42	4,84	1,22	116,0	0,61	2,15
RGT= 32/90	-20	-4	193,1	660	166,2	1,55	5,30	1,34	124,4	0,64	2,52
liquid temp	-15	5	244,2	834	210,1	1,75	5,96	1,50	139,9	0,71	3,20
Tliq= 55/131	-10	14	304,4	1040	262,0	1,92	6,56	1,65	158,5	0,79	4,00

## Model

Designation **HXK12AT** **208-230V/60Hz** Conf. 3 Sales code: **16470500**

## Configuration

Motor configuration RSCR  
 Power supply (nominal) 208-230V/60Hz 1~  
 Refrigerant R600a  
 Application LBP  
 Voltage range 198-253V  
 Starting torque LST  
 Approvals VDE

## Electrical accessories / wiring diagram

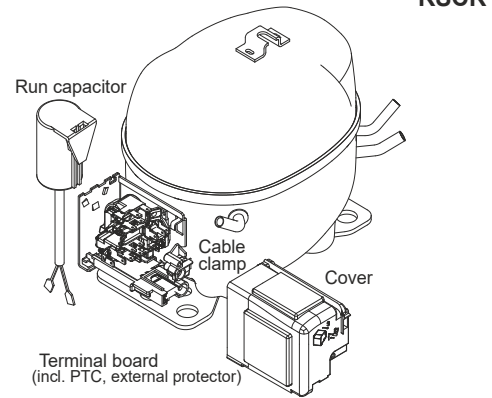

## Ambient/ machine room temperatures minimum /maximum

Ambient temperature range: 10 - 43°C / 50 - 110°F

Machine room temperature range: 10 - 48°C / 50 - 119°F

Compressor cooling: static

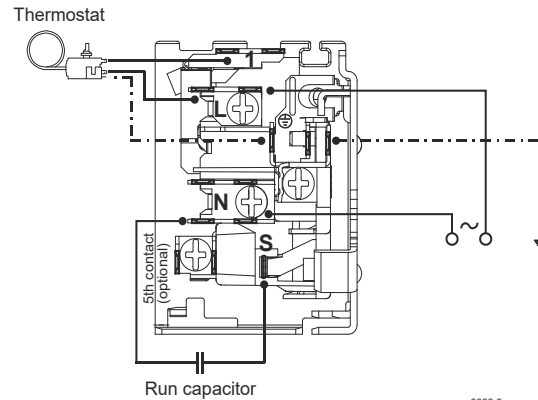

## Operation pressure range

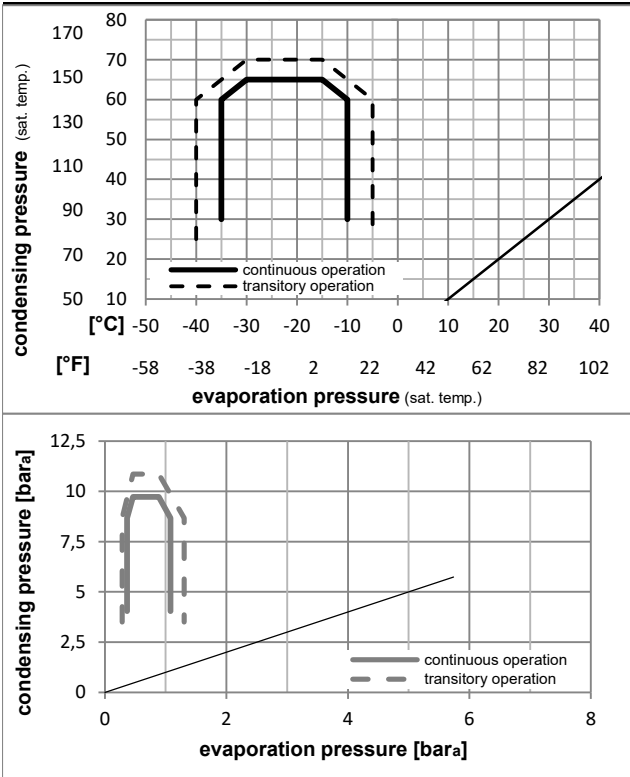

## Components

- . terminal board (PTC, 4.8mm) 16425900
- . run capacitor (4μF, 4.8mm) 10693001
- b cover terminal board 10636401
- . cable clamp 16058100
- . screw - uni6954 10636000
- . screw - uni6954 10636200

## Alternative components

- . terminal board (PTC, 6.3mm) 16425700
- . run capacitor (4μF, 4.8mm) 16344500
- . run capacitor (4μF, 6.3mm) 15186801
- . screw uni en iso 4757 10641201

## Model

Designation **HXK12AT** **208-230V/60Hz** Conf. 3 Sales code: **16470500**

## Optimization + standard conditions

R600a, 220V/60Hz, RSCR, static, VDE

	Evaporating pressure (saturation temperature)				Condensing pressure (saturation temperature)			COP	EER	P1	Power consumption		Ref. mass flow	ASHRAE LBP
	pe	pc	RGT	Tliq	[W]	[Btu/h]	[kcal/h]				I	m		
	[°C]	[°F]	[°C]	[°F]	[W]	[Btu/h]	[kcal/h]	[W/W]	[Btu/Wh]	[kcal/Wh]	[W]	[A]	[kg/h]	
	-23	54	32	32	235,6	805	202,8	1,75	5,97	1,50	134,8	0,71	2,53	ASHRAE LBP
	-10	130	90	90										
	-25	55	32	55	178,2	608	153,3	1,36	4,64	1,17	131,1	0,70	2,32	cecomaf LBP
	-13	131	90	131										
	-35	40	20	40	134,1	458	115,4	1,25	4,27	1,08	107,2	0,62	1,63	EN12900 LBP
	-31	104	68	104										
	-23	49	4,4	49	189,8	648	163,3	1,47	5,01	1,26	129,4	0,70	2,77	ARI540 LBP
	-10	120	40	120										
	-23	41	32	32	245,3	838	211,1	2,01	6,85	1,73	122,2	0,68	2,63	AHAM LBP
	-10	105	90	90										
	-35	45	32	45	131,0	447	112,7	1,19	4,05	1,02	110,5	0,63	1,56	opt
	-31	113	90	113										

## Performance tables

R600a, 220V/60Hz, RSCR, static, VDE

	pe		Cooling capacity			COP	EER		P1	I	m
	[°C]	[°F]	[W]	[Btu/h]	[kcal/h]	[W/W]	[Btu/Wh]	[kcal/Wh]	[W]	[A]	[kg/h]
[°C / °F]	-35	-31	131,0	447	112,7	1,19	4,05	1,02	110,5	0,63	1,56
cond. pressure	-30	-22	160,3	547	137,9	1,41	4,81	1,21	113,9	0,64	1,91
pc= 45/113	-25	-13	202,2	690	174,0	1,66	5,66	1,43	122,1	0,67	2,41
return gas temp.	-23	-10	219,3	749	188,7	1,74	5,95	1,50	125,8	0,69	2,61
RGT= 32/90	-20	-4	256,6	876	220,9	1,91	6,51	1,64	134,6	0,72	3,06
liquid temp	-15	5	323,7	1105	278,5	2,14	7,32	1,84	151,0	0,79	3,87
Tliq= 45/113	-10	14	403,2	1377	347,0	2,36	8,05	2,03	171,0	0,88	4,83
[°C / °F]	-35	-31	112,3	383	96,6	0,96	3,28	0,83	116,8	0,65	1,46
cond. pressure	-30	-22	139,8	477	120,3	1,15	3,93	0,99	121,4	0,66	1,82
pc= 55/131	-25	-13	178,2	608	153,3	1,36	4,64	1,17	131,1	0,70	2,32
return gas temp	-23	-10	193,7	661	166,7	1,43	4,88	1,23	135,5	0,71	2,53
RGT= 32/90	-20	-4	227,4	777	195,7	1,56	5,34	1,35	145,4	0,76	2,97
liquid temp	-15	5	287,6	982	247,5	1,76	5,99	1,51	163,8	0,84	3,77
Tliq= 55/131	-10	14	358,6	1225	308,6	1,93	6,58	1,66	186,0	0,93	4,71