

Model

Designation	HXK95AT	200-240V/50Hz 1~ 208-230V/60Hz 1~	Sales code:	16513300
-------------	----------------	-----------------------------------	-------------	-----------------

Compressor design

Oil type	Mineral	Refrigerant(s)	R600a
Oil viscosity	5cSt	Displacement	9,6cm ³ / 0,59cu.in
Oil quantity	162cm ³ / 5,5fl.oz	Compressors on pallet	100
Refr. charge - tech. limit	150g / 5,3oz		
Free gas volume comp.	1560cm ³ / 52,7fl.oz		
Weight	9,3kg / 20,5lbs		
Motor protection	external		
Winding resistance main	15,5Ω (at 25°C)		
Winding resistance aux	9,9Ω (at 25°C)		
Max. winding temp.	130°C / 266°F		
Max. discharge temp.	130°C / 266°F		



General - Configurations with HXK95AT

	Conf. 1	Conf. 2
Motor configuration	RSCR	RSCR
Power supply (nominal)	220-240V/50Hz	208-230V/60Hz
Number of phases	1	1
Voltage range	170-264V	198-253V
Approvals	VDE	VDE
Starting torque	LST	LST
Note	Electrical equipment is included and pre-assembled to compressor.	

Applications with HXK95AT

	Conf. 1	Conf. 2
Refrigerant	R600a	R600a
Application	LBP	LBP
System cooling	static	static
Hot gas defrost	-/-	-/-
Long interval pull down	-/-	-/-

Electrical data - Configurations with HXK95AT

	Conf. 1	Conf. 2
Starting device type	PTC	PTC
Run capacitor	4μF	4μF
Start capacitor	-/-	-/-
LRA (locked rotor amps / 4s/ U(N))	6A	6A
RLA (rated load amps / 1s/ U(N))	0,55A	0,55A
Cut in current (U(N))	13,1A	13,7A

Model

Designation **HXK95AT** 200-240V/50Hz 1~ 208-230V/60Hz 1~ Sales code: **16513300**

Compressor dimensions

Housing	A Height	174mm / 6,85in
	B Height	167mm / 6,57in
	C Length shell	194mm / 7,64in
	D Length w. cover	238mm / 9,37in
	E Width	151mm / 5,94in

Connectors	Suction	Discharge	Process	
	X	Y	Z	
Diameter [mm]	øi 6,1-6,2	øi 5,1-5,2	øo 5,92-6,08	
(i:inside, o:outside) [in]	øi 0,24-0,24	øi 0,2-0,2	øo 0,23-0,24	
Material	copper	copper	copper	
Horizontal angle	±2° 45°	13°	0°	
Vertical angle	±2° 30°	40°	145°	
Position l/h/w	[mm]	120/72/62	112/106/62	-140/136/70
	[in]	4,7/2,8/2,4	4,4/4,2/2,4	-5,5/5,4/2,8
Straight tube l.	[mm]	14	14	75
	[in]	0,5	0,5	3

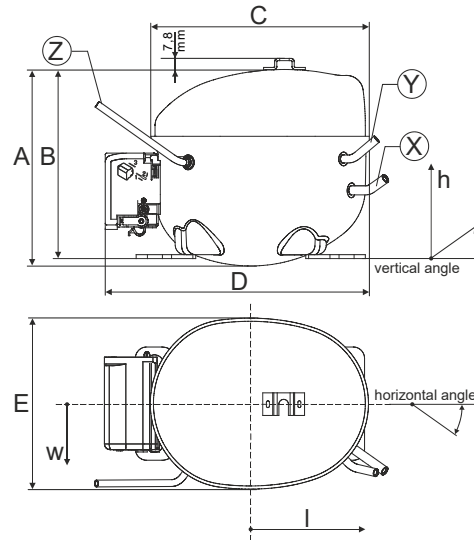

Compressor fixation

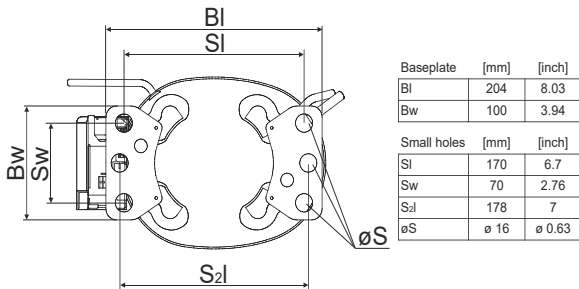

Bolt joint

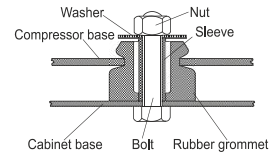

Snap-on

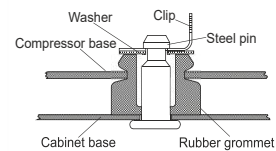

Mounting accessories

- '4ZN' with rubber grommet
- '4ZN' with rubber grommet and sleeve for M6
- Bolt joint kit
- '4ZN' with Snap on kit

- order code
- 772N
 - 768N
 - 4ZN + 118-1917 (18)
 - 776N

Application notes

Provision for PE Grounding is located at the PE Stamp on the compressor Housing with dip-tray fixture (omega bracket).

Model

Designation **HXK95AT** **220-240V/50Hz** Conf. 1 Sales code: **16513300**

Configuration

Motor configuration RSCR
 Power supply (nominal) 220-240V/50Hz 1~
 Refrigerant R600a
 Application LBP
 Voltage range 170-264V
 Starting torque LST
 Approvals VDE

Electrical accessories / wiring diagram

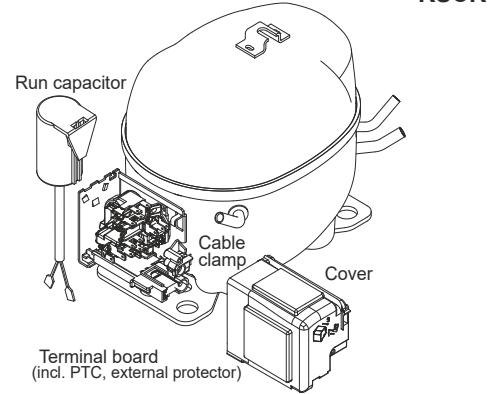

Ambient/ machine room temperatures minimum /maximum

Ambient temperature range: 10 - 43°C / 50 - 110°F
 Machine room temperature range: 10 - 48°C / 50 - 119°F
 Compressor cooling: static

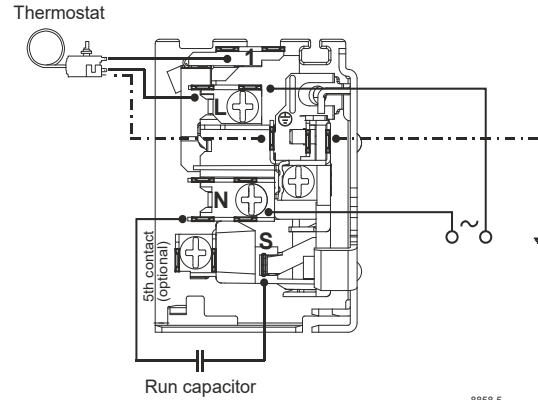

Operation pressure range

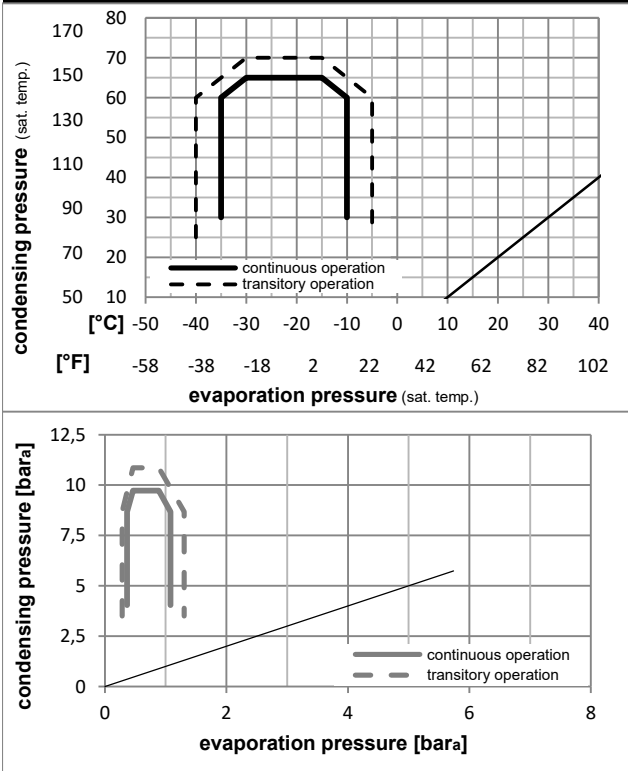

Components (incl. and pre. assemb.)

- terminal board (PTC, 4.8mm) 16403800
- run capacitor (4μF, 4.8mm) 11261700
- b, d cover + clamp + screws(5VA-compl.) 103N0600

Alternative comp.

- b, d 100x cover + clamp + screws(5VA) 103N2060
- b, d cover + clamp + screws(5VA) in bag 103N1060

Model

Designation **HXK95AT** **220-240V/50Hz** Conf. 1 Sales code: **16513300**

Optimization + standard conditions

R600a, 230V/50Hz, RSCR, static, VDE

	Evaporating pressure (saturation temperature)				Cooling capacity			COP	EER		Power consumption			
	Condensing pressure (saturation temperature)				Return gas temp.						Current consumption			Ref. mass flow
	pe	pc	RGT	Tliq	[W]	[Btu/h]	[kcal/h]	[W/W]	[Btu/Wh]	[kcal/Wh]	P1	I	m	
	[°C]	[°C]	[°C]	[°C]	[W]	[Btu/h]	[kcal/h]	[W/W]	[Btu/Wh]	[kcal/Wh]	[W]	[A]	[kg/h]	
ASHRAE LBP	-23	54	32	32	173,4	592	149,2	1,68	5,73	1,44	103,4	0,58	1,86	
	[°F]	[°F]	[°F]	[°F]										
cecomaf LBP	-25	55	32	55	130,1	444	112,0	1,32	4,51	1,14	98,6	0,56	1,70	
	[°F]	[°F]	[°F]	[°F]										
EN12900 LBP	-35	40	20	40	93,8	320	80,8	1,39	4,75	1,20	67,4	0,45	1,14	
	[°F]	[°F]	[°F]	[°F]										
ARI540 LBP	-23	49	4,4	49	139,8	477	120,3	1,39	4,74	1,20	100,6	0,57	2,04	
	[°F]	[°F]	[°F]	[°F]										
AHAM LBP	-23	41	32	32	179,1	612	154,1	1,87	6,40	1,61	95,5	0,55	1,92	
	[°F]	[°F]	[°F]	[°F]										
opt	-35	45	32	45	89,2	305	76,7	1,36	4,65	1,17	65,5	0,44	1,06	
	[°F]	[°F]	[°F]	[°F]										

Performance tables

R600a, 230V/50Hz, RSCR, static, VDE

	pe		Cooling capacity			COP	EER		P1	I	m
	[°C]	[°F]	[W]	[Btu/h]	[kcal/h]	[W/W]	[Btu/Wh]	[kcal/Wh]	[W]	[A]	[kg/h]
[°C / °F]	-35	-31	89,2	305	76,7	1,36	4,65	1,17	65,5	0,44	1,06
cond. pressure	-30	-22	116,6	398	100,4	1,42	4,85	1,22	82,2	0,50	1,39
pc= 45/113	-25	-13	148,6	507	127,9	1,57	5,36	1,35	94,7	0,55	1,77
return gas temp.	-23	-10	160,8	549	138,4	1,64	5,59	1,41	98,3	0,56	1,92
RGT= 32/90	-20	-4	187,0	639	161,0	1,78	6,09	1,54	104,8	0,59	2,23
liquid temp	-15	5	233,9	799	201,3	2,04	6,98	1,76	114,4	0,63	2,79
Tliq= 45/113	-10	14	291,1	994	250,5	2,32	7,93	2,00	125,4	0,67	3,48
[°C / °F]	-35	-31	60,4	206	52,0	1,05	3,60	0,91	57,4	0,41	0,79
cond. pressure	-30	-22	95,2	325	81,9	1,18	4,02	1,01	80,8	0,49	1,24
pc= 55/131	-25	-13	130,1	444	112,0	1,32	4,51	1,14	98,6	0,56	1,70
return gas temp	-23	-10	142,4	486	122,6	1,37	4,69	1,18	103,7	0,58	1,86
RGT= 32/90	-20	-4	167,3	571	144,0	1,49	5,07	1,28	112,6	0,62	2,19
liquid temp	-15	5	208,5	712	179,5	1,67	5,71	1,44	124,6	0,67	2,73
Tliq= 55/131	-10	14	255,8	874	220,2	1,87	6,40	1,61	136,5	0,72	3,36

Model

Designation **HXK95AT** **208-230V/60Hz** Conf. 2 Sales code: **16513300**

Configuration

Motor configuration RSCR
 Power supply (nominal) 208-230V/60Hz 1~
 Refrigerant R600a
 Application LBP
 Voltage range 198-253V
 Starting torque LST
 Approvals VDE

Electrical accessories / wiring diagram

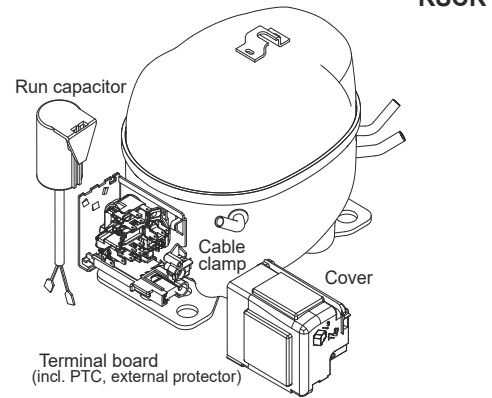

Ambient/ machine room temperatures minimum /maximum

Ambient temperature range: 10 - 43°C / 50 - 110°F
 Machine room temperature range: 10 - 48°C / 50 - 119°F
 Compressor cooling: static

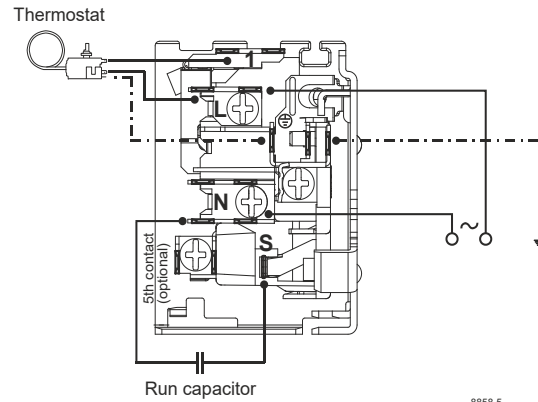

Operation pressure range

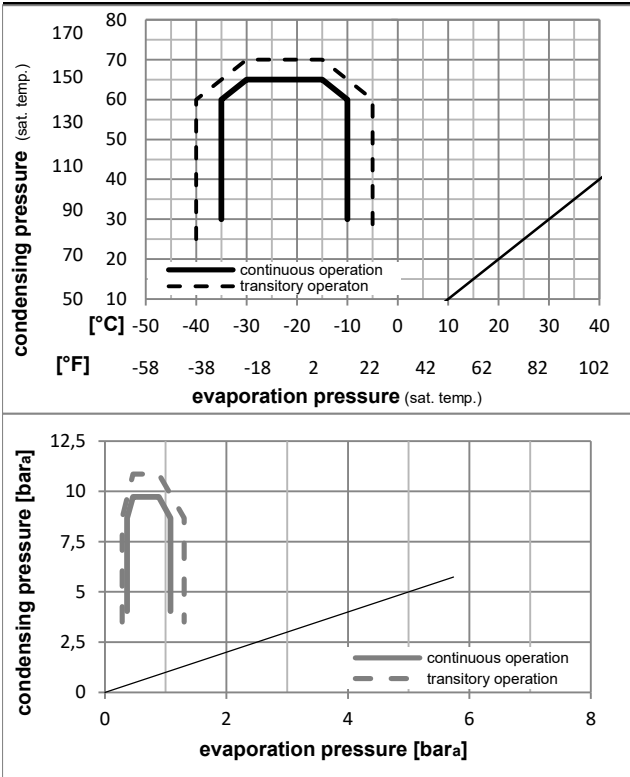

Components (incl. and pre. assemb.)

- . terminal board (PTC, 4.8mm) 16403800
- . run capacitor (4μF, 4.8mm) 11261700
- b, d cover + clamp + screws(5VA-compl.) 103N0600

Alternative comp.

- b, d 100x cover + clamp + screws(5VA) 103N2060
- b, d cover + clamp + screws(5VA) in bag 103N1060

Model

Designation **HXK95AT** **208-230V/60Hz** Conf. 2 Sales code: **16513300**

Optimization + standard conditions

R600a, 220V/60Hz, RSCR, static, VDE

	Evaporating pressure (saturation temperature)				Condensing pressure (saturation temperature)			COP	EER	Power consumption			ASHRAE LBP	
	pe	pc	RGT	Tliq	[W]	[Btu/h]	[kcal/h]			P1	I	m		
	[°C]	[°F]	[°C]	[°F]	[W]	[Btu/h]	[kcal/h]	[W/W]	[Btu/Wh]	[kcal/Wh]	[W]	[A]	[kg/h]	
	-23	54	32	32	200,6	685	172,7	1,77	6,04	1,52	113,5	0,59	2,15	ASHRAE LBP
	-10	130	90	90										
	-25	55	32	55	151,3	517	130,3	1,39	4,73	1,19	109,2	0,56	1,97	cecomaf LBP
	-13	131	90	131										
	-35	40	20	40	115,8	396	99,7	1,36	4,66	1,17	84,9	0,40	1,41	EN12900 LBP
	-31	104	68	104										
	-23	49	4,4	49	161,0	550	138,5	1,46	4,98	1,26	110,4	0,58	2,35	ARI540 LBP
	-10	120	40	120										
	-23	41	32	32	206,5	705	177,7	1,97	6,73	1,69	104,9	0,56	2,22	AHAM LBP
	-10	105	90	90										
	-35	45	32	45	113,7	388	97,9	1,31	4,49	1,13	86,5	0,38	1,35	opt
	-31	113	90	113										

Performance tables

R600a, 220V/60Hz, RSCR, static, VDE

	pe		Cooling capacity			COP	EER		P1	I	m
	[°C]	[°F]	[W]	[Btu/h]	[kcal/h]	[W/W]	[Btu/Wh]	[kcal/Wh]	[W]	[A]	[kg/h]
[°C / °F]	-35	-31	113,7	388	97,9	1,31	4,49	1,13	86,5	0,38	1,35
cond. pressure	-30	-22	135,6	463	116,7	1,44	4,92	1,24	94,1	0,47	1,61
pc= 45/113	-25	-13	170,3	582	146,6	1,64	5,59	1,41	104,1	0,55	2,03
return gas temp.	-23	-10	184,9	632	159,1	1,71	5,85	1,47	107,9	0,57	2,20
RGT= 32/90	-20	-4	217,0	741	186,7	1,87	6,40	1,61	115,8	0,60	2,59
liquid temp	-15	5	274,5	938	236,3	2,13	7,29	1,84	128,6	0,65	3,28
Tliq= 45/113	-10	14	342,1	1168	294,4	2,41	8,23	2,07	142,0	0,71	4,10
[°C / °F]	-35	-31	95,3	326	82,0	1,10	3,76	0,95	86,6	0,32	1,24
cond. pressure	-30	-22	118,1	403	101,7	1,22	4,17	1,05	96,8	0,46	1,54
pc= 55/131	-25	-13	151,3	517	130,3	1,39	4,73	1,19	109,2	0,56	1,97
return gas temp	-23	-10	164,8	563	141,9	1,45	4,94	1,25	113,8	0,59	2,15
RGT= 32/90	-20	-4	194,0	663	167,0	1,57	5,38	1,36	123,2	0,64	2,54
liquid temp	-15	5	245,2	837	211,0	1,77	6,06	1,53	138,2	0,70	3,21
Tliq= 55/131	-10	14	303,9	1038	261,6	1,98	6,76	1,70	153,4	0,77	3,99