

Model

Designation	KLE4.8GFTX	220-240V/50Hz 1~ 208-230V/60Hz 1~	Sales code:	106G5518
-------------	-------------------	-----------------------------------	-------------	-----------------

Compressor design

Oil type	Polyolester	Refrigerant(s)	R134a, R513A
Oil viscosity	19,2cSt	Displacement	4,8cm ³ / 0,29cu.in
Oil quantity	240cm ³ / 8,1fl.oz	Compressors on pallet	100
Refr. charge - tech. limit	250g / 8,8oz		
Free gas volume comp.	1545cm ³ / 52,2fl.oz		
Weight	9,3kg / 20,5lbs		
Motor protection	external		
Winding resistance main	13,1Ω (at 25°C)		
Winding resistance aux	25,3Ω (at 25°C)		
Max. winding temp.	125°C / 257°F		
Max. discharge temp.	130°C / 266°F		
Additional note	Good robustness against liquid intake. Ice-cube maker optimization - indirect suction intake.		



General - Configurations with KLE4.8GFTX

	Conf. 1	Conf. 2
Motor configuration	CSIR	CSIR
Power supply (nominal)	220-240V/50Hz	208-230V/60Hz
Number of phases	1	1
Voltage range	187-254V	198-253V
Approvals	VDE, CB, CCC, UL	VDE, CB, CCC, UL
Starting torque	HST	HST
Note	Electrical equipment is included and pre-assembled to compressor.	

Applications with KLE4.8GFTX

	Conf. 1	Conf. 2
Refrigerant	R134a	R134a
Application	LBP+MBP+HBP	LBP+MBP
System cooling	fan 3m/s	fan 3m/s
Hot gas defrost	OK	OK
Long interval pull down	OK	OK

Electrical data - Configurations with KLE4.8GFTX

	Conf. 1	Conf. 2
Starting device type	relay	relay
Run capacitor	-/-	-/-
Start capacitor	80μF	80μF
LRA (locked rotor amps / 4s/ U(N))	10,5A	
RLA (rated load amps / 1s/ U(N))	1A	
Cut in current (U(N))	10,2A	

Model

Designation **KLE4.8GFTX** 220-240V/50Hz 1~ 208-230V/60Hz 1~ Sales code: **106G5518**

Compressor dimensions

Housing	A Height	174mm / 6,85in
	B Height	167mm / 6,57in
	C Length shell	194mm / 7,64in
	D Length w. cover	235,1mm / 9,26in
	E Width	151mm / 5,94in

Connectors		Suction	Discharge	Process
		X	Y	Z
Diameter	[mm]	øi 8,11-8,29	øi 6,11-6,29	øi 6,11-6,29
	(i:inside, o:outside) [in]	øi 0,32-0,33	øi 0,24-0,25	øi 0,24-0,25
Material		copper	copper	copper
Horizontal angle	±2°	35°	13°	0°
Vertical angle	±2°	30°	40°	145°
Position l/h/w	[mm]	119/73/59	114/107/63	-87/101/71
	[in]	4,7/2,9/2,3	4,5/4,2/2,5	-3,4/4/2,8
Straight tube l.	[mm]	14	14	14
	[in]	0,5	0,5	0,5

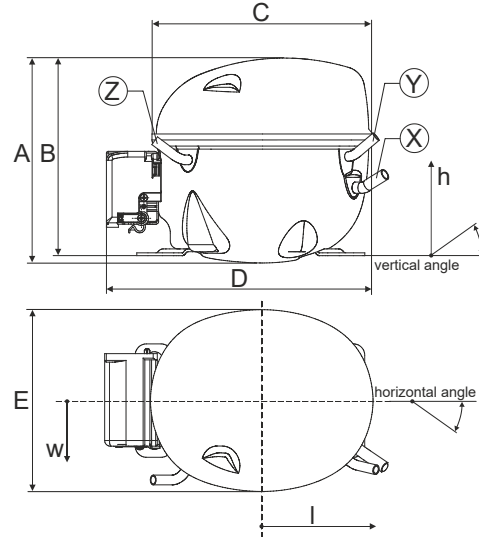

Compressor fixation

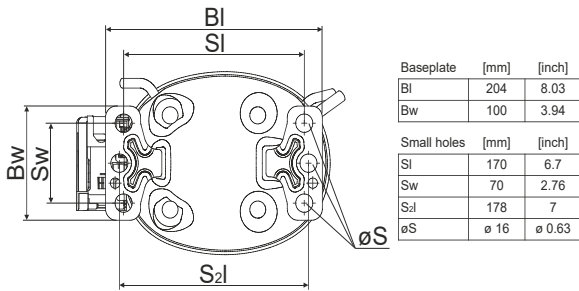

Bolt joint

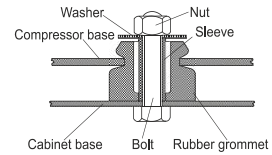

Snap-on

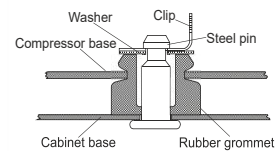

Mounting accessories	one comp.	multi pack
Bolt joint M6 ø16mm	118-1917	118-1918
Bolt joint ø1/4" ø16mm	118-1946	
Snap-on ø7,3 ø16mm	118-1947	118-1919

Application notes

Compressor with low height version.
 Provision for PE Grounding is located at the PE Stamp on the compressor

Model

Designation **KLE4.8GFTX** **220-240V/50Hz** Conf. 1 Sales code: **106G5518**

Configuration

Motor configuration CSIR
 Power supply (nominal) 220-240V/50Hz 1~
 Refrigerant R134a
 Application LBP+MBP+HBP
 Voltage range 187-254V
 Starting torque HST
 Approvals VDE
 CB
 CCC
 UL

Electrical accessories / wiring diagram

CSIR

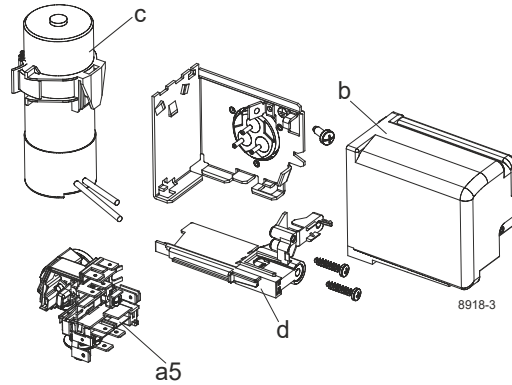

Ambient/ machine room temperatures minimum /maximum

Ambient temperature range: 10 - 43°C / 50 - 110°F

Machine room temperature range: 10 - 48°C / 50 - 119°F

Compressor cooling: fan 3m/s

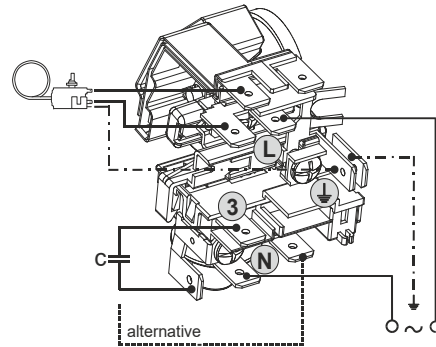

Operation pressure range

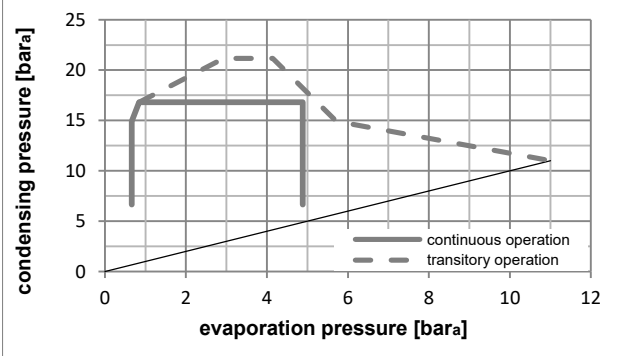
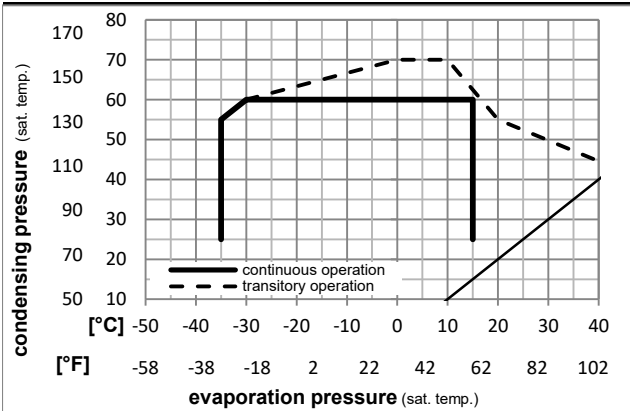

Components (incl. and pre. assemb.)

- a5 current relay (T1189/L6-S3) 117U7073
- c start capacitor (80µF, 6.3mm) 117U5001
- b, d cover + clamp + screws(5VA-compl.) 103N0600

Alternative comp.

- b, d 100x cover + clamp + screws(5VA) 103N2060
- b, d cover + clamp + screws(5VA) in bag 103N1060

Model

Designation **KLE4.8GFTX 220-240V/50Hz** Conf. 1 Sales code: **106G5518**

Optimization + standard conditions

R134a, 220V/50Hz, CSIR, fan 3m/s, VDE, CB, CCC, UL

		Evaporating pressure (saturation temperature)				Condensing pressure (saturation temperature)						Power consumption			
		Return gas temp.				Liquid temp.						Current consumption			Ref. mass flow
		Cooling capacity				COP		EER		P1	I	m			
		pe	pc	RGT	Tliq	[W]	[Btu/h]	[kcal/h]	[W/W]	[Btu/Wh]	[kcal/Wh]	[W]	[A]	[kg/h]	
[°C]	-23	54	32	32	129,7	443	111,6	1,26	4,31	1,09	102,8	1,18	2,52	ASHRAE LBP	
[°F]	-10	130	90	90											
[°C]	-7	54	35	46	279,9	956	240,9	1,88	6,42	1,62	148,9	1,29	6,11	ASHRAE MBP	
[°F]	20	130	95	115											
[°C]	7,2	54	35	46	502,3	1715	432,3	2,71	9,26	2,33	185,2	1,41	11,14	ASHRAE HBP	
[°F]	45	130	95	115											
[°C]	-35	40	20	40	64,4	220	55,4	0,88	3,01	0,76	73,0	1,12	1,41	EN12900 LBP	
[°F]	-31	104	68	104											
[°C]	-10	45	20	45	241,7	825	208,0	1,87	6,38	1,61	129,3	1,24	5,66	EN12900 MBP	
[°F]	14	113	68	113											
[°C]	5	50	20	50	428,2	1462	368,5	2,49	8,51	2,15	171,8	1,36	10,79	EN12900 HBP	
[°F]	41	122	68	122											

Performance tables

R134a, 220V/50Hz, CSIR, fan 3m/s, VDE, CB, CCC, UL

	pe		Cooling capacity			COP		EER		P1	I	m
	[°C]	[°F]	[W]	[Btu/h]	[kcal/h]	[W/W]	[Btu/Wh]	[kcal/Wh]	[W]	[A]	[kg/h]	
[°C / °F]	-35	-31	60,4	206	52,0	0,83	2,85	0,72	72,4	1,12	1,30	
cond. pressure	-25	-13	111,8	382	96,2	1,17	4,00	1,01	95,5	1,17	2,42	
pc= 45/113	-15	5	195,3	667	168,1	1,65	5,65	1,42	118,1	1,22	4,26	
return gas temp.	-10	14	250,7	856	215,8	1,94	6,62	1,67	129,3	1,24	5,49	
RGT= 32/90	0	32	392,4	1340	337,7	2,59	8,83	2,23	151,7	1,30	8,68	
liquid temp	5	41	479,9	1639	413,0	2,95	10,06	2,53	163,0	1,33	10,69	
Tliq= 45/113	15	59	691,7	2362	595,3	3,72	12,72	3,20	185,8	1,41	15,67	
[°C / °F]	-35	-31	48,8	167	42,0	0,72	2,46	0,62	67,8	1,11	1,16	
cond. pressure	-25	-13	94,7	324	81,5	0,97	3,30	0,83	97,9	1,17	2,27	
pc= 55/131	-15	5	167,6	572	144,3	1,32	4,52	1,14	126,6	1,24	4,04	
return gas temp	-10	14	215,8	737	185,7	1,54	5,25	1,32	140,4	1,27	5,22	
RGT= 32/90	0	32	339,1	1158	291,8	2,03	6,92	1,74	167,3	1,35	8,29	
liquid temp	5	41	415,5	1419	357,6	2,30	7,87	1,98	180,4	1,39	10,24	
Tliq= 55/131	15	59	601,1	2053	517,3	2,92	9,96	2,51	206,1	1,49	15,10	

Model

Designation **KLE4.8GFTX** **208-230V/60Hz** Conf. 2 Sales code: **106G5518**

Configuration

Motor configuration CSIR
 Power supply (nominal) 208-230V/60Hz 1~
 Refrigerant R134a
 Application LBP+MBP
 Voltage range 198-253V
 Starting torque HST
 Approvals VDE
 CB
 CCC
 UL

Electrical accessories / wiring diagram

CSIR

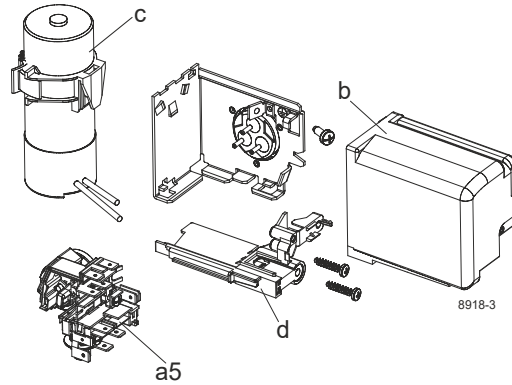

Ambient/ machine room temperatures minimum /maximum

Ambient temperature range: 10 - 43°C / 50 - 110°F

Machine room temperature range: 10 - 48°C / 50 - 119°F

Compressor cooling: fan 3m/s

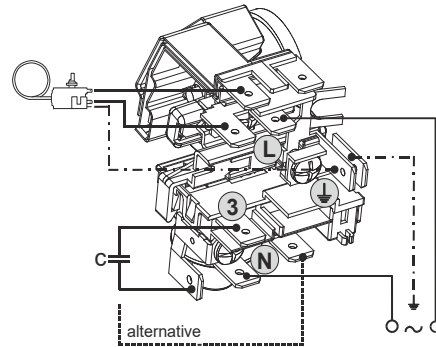

Operation pressure range

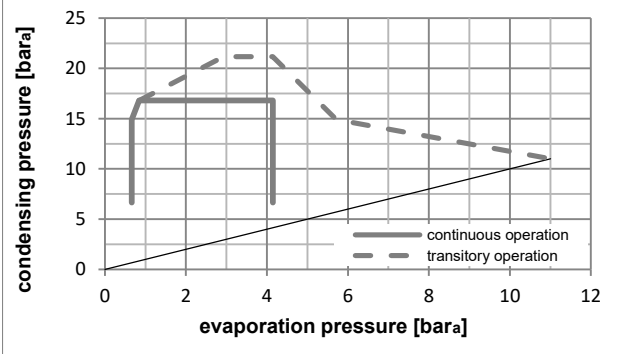
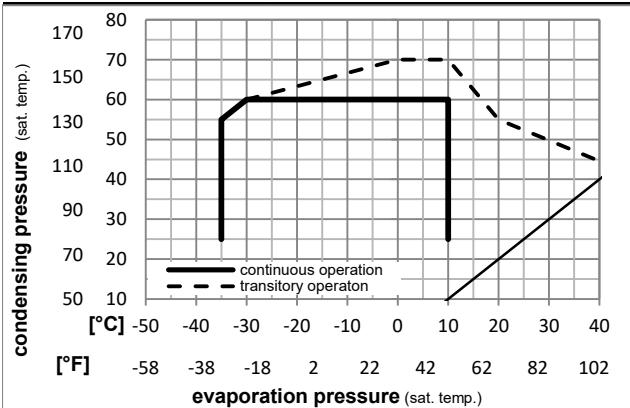

Components (incl. and pre. assemb.)

- a5 current relay (T1189/L6-S3) 117U7073
- c start capacitor (80µF, 6.3mm) 117U5001
- b, d cover + clamp + screws(5VA-compl.) 103N0600

Alternative comp.

- b, d 100x cover + clamp + screws(5VA) 103N2060
- b, d cover + clamp + screws(5VA) in bag 103N1060

Model

Designation **KLE4.8GFTX** **208-230V/60Hz** Conf. 2 Sales code: **106G5518**

Optimization + standard conditions

R134a, 230V/60Hz, CSIR, fan 3m/s, VDE, CB, CCC, UL

	Evaporating pressure (saturation temperature)				Condensing pressure (saturation temperature)			COP	EER	P1	Power consumption		Ref. mass flow				
	pe	pc	RGT	Tliq	[W]	[Btu/h]	[kcal/h]				I	m					
	[°C]	[°F]	[°C]	[°F]	[W]	[Btu/h]	[kcal/h]	[W/W]	[Btu/Wh]	[kcal/Wh]	[W]	[A]	[kg/h]				
ASHRAE LBP	-23	-10	54	130	32	90	32	90	154,4	527	132,9	1,30	4,44	1,12	118,6	1,13	3,00
ASHRAE MBP	-7	20	54	130	35	95	46	115	330,5	1129	284,4	1,92	6,55	1,65	172,2	1,26	7,21
ASHRAE HBP	7,2	45	54	130	35	95	46	115	587,3	2006	505,4	2,71	9,25	2,33	216,9	1,39	13,03
EN12900 LBP	-35	-31	40	104	20	68	40	104	81,6	279	70,2	0,94	3,22	0,81	86,7	1,08	1,79
EN12900 MBP	-10	14	45	113	20	68	45	113	281,8	963	242,6	1,87	6,39	1,61	150,6	1,20	6,60
EN12900 HBP	5	41	50	122	20	68	50	122	500,8	1710	431,0	2,45	8,37	2,11	204,3	1,35	12,62

Performance tables

R134a, 230V/60Hz, CSIR, fan 3m/s, VDE, CB, CCC, UL

	pe		Cooling capacity			COP	EER		P1	I	m
	[°C]	[°F]	[W]	[Btu/h]	[kcal/h]	[W/W]	[Btu/Wh]	[kcal/Wh]	[W]	[A]	[kg/h]
[°C / °F]	-35	-31	76,1	260	65,5	0,89	3,05	0,77	85,3	1,07	1,64
cond. pressure	-25	-13	131,2	448	112,9	1,21	4,13	1,04	108,4	1,11	2,84
pc= 45/113	-15	5	227,5	777	195,8	1,68	5,72	1,44	135,8	1,17	4,96
return gas temp.	-10	14	292,4	999	251,6	1,94	6,63	1,67	150,6	1,20	6,40
RGT= 32/90	0	32	458,1	1565	394,3	2,53	8,64	2,18	181,0	1,28	10,13
liquid temp	5	41	560,0	1912	481,9	2,85	9,75	2,46	196,2	1,33	12,47
Tliq= 45/113	15	59	804,3	2747	692,2	3,57	12,20	3,07	225,2	1,42	18,22
[°C / °F]	-35	-31	61,0	208	52,5	0,71	2,43	0,61	85,9	1,08	1,45
cond. pressure	-25	-13	113,1	386	97,4	0,99	3,39	0,85	114,1	1,12	2,71
pc= 55/131	-15	5	198,8	679	171,1	1,37	4,66	1,18	145,5	1,19	4,78
return gas temp	-10	14	255,4	872	219,8	1,58	5,39	1,36	161,9	1,23	6,18
RGT= 32/90	0	32	398,9	1362	343,3	2,05	7,00	1,76	194,7	1,32	9,76
liquid temp	5	41	486,8	1662	418,9	2,31	7,89	1,99	210,7	1,37	12,00
Tliq= 55/131	15	59	697,4	2382	600,2	2,90	9,90	2,50	240,5	1,48	17,52