

Model

Designation	KLF4.0CNH	115-127V/60Hz 1~	Sales code:	106H3408
-------------	------------------	------------------	-------------	-----------------

Compressor design

Oil type	Polyolester	Refrigerant(s)	R290
Oil viscosity	10,4cSt	Displacement	4cm ³ / 0,24cu.in
Oil quantity	170cm ³ / 5,7fl.oz	Compressors on pallet	100
Refr. charge - tech. limit	200g / 7,1oz		
Free gas volume comp.	1630cm ³ / 55,1fl.oz		
Weight	8,62kg / 19lbs		
Motor protection	external		
Winding resistance main	3,4Ω (at 25°C)		
Winding resistance aux	8Ω (at 25°C)		
Max. winding temp.	125°C / 257°F		
Max. discharge temp.	130°C / 266°F		



General - Configurations with KLF4.0CNH

	Conf. 1	Conf. 2
Motor configuration	CSIR	RSCR
Power supply (nominal)	115-127V/60Hz	115-127V/60Hz
Number of phases	1	1
Voltage range	95-140V	95-140V
Approvals	UL, CCC	UL, CCC
Starting torque	HST	LST
Note	Compressor with low height version.	

Applications with KLF4.0CNH

	Conf. 1	Conf. 2
Refrigerant	R290	R290
Application	LBP+MBP	LBP+MBP
System cooling	fan 3m/s	fan 3m/s
Hot gas defrost	OK	OK
Long interval pull down	OK	OK

Electrical data - Configurations with KLF4.0CNH

	Conf. 1	Conf. 2
Starting device type	relay	PTC
Run capacitor	-/-	15μF
Start capacitor	240μF	-/-
LRA (locked rotor amps / 4s/ U(N))	21,2A	21,2A
RLA (rated load amps / 1s/ U(N))	2,7A	2,7A
Cut in current (U(N))	20,5A	23,1A

Model

Designation	KLF4.0CNH	115-127V/60Hz 1~	Sales code:	106H3408
-------------	------------------	------------------	-------------	-----------------

Compressor dimensions

Housing	A Height	174mm / 6,85in
	B Height	167mm / 6,57in
	C Length shell	194mm / 7,64in
	D Length w. cover	235,1mm / 9,26in
	E Width	151mm / 5,94in

Connectors		Suction	Discharge	Process
		X	Y	Z
Diameter	[mm]	øi 8,11-8,29	øi 6,11-6,29	øi 6,11-6,29
(i:inside, o:outside)	[in]	øi 0,32-0,33	øi 0,24-0,25	øi 0,24-0,25
Material		copper	copper	copper
Horizontal angle	±2°	35°	13°	0°
Vertical angle	±2°	30°	40°	145°
Position l/h/w	[mm]	119/73/59	114/107/63	-87/101/71
	[in]	4,7/2,9/2,3	4,5/4,2/2,5	-3,4/4/2,8
Straight tube l.	[mm]	14	14	14
	[in]	0,5	0,5	0,5

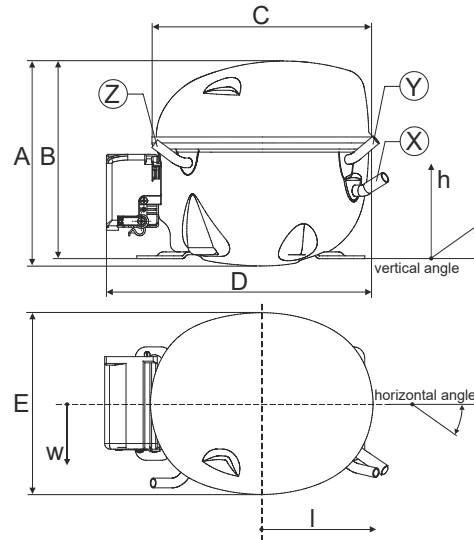

Compressor fixation

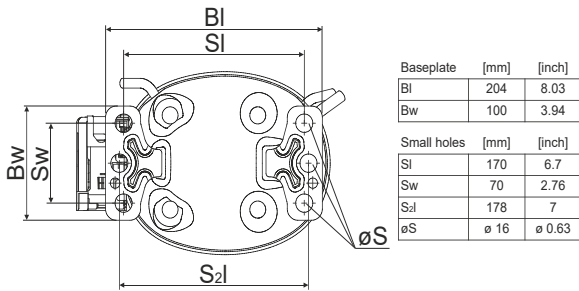

Bolt joint

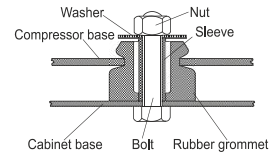

Snap-on

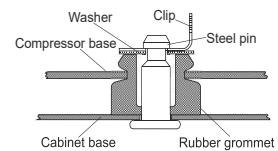

Mounting accessories

	one comp.	multi pack
Bolt joint M6 ø16mm	118-1917	118-1918
Bolt joint ø1/4" ø16mm	118-1946	
Snap-on ø7,3 ø16mm	118-1947	118-1919

Application notes

Provision for PE Grounding is located at the PE Stamp on the compressor

Model

Designation **KLF4.0CNH** **115-127V/60Hz** Conf. 1 Sales code: **106H3408**

Configuration

Motor configuration CSIR
 Power supply (nominal) 115-127V/60Hz 1~
 Refrigerant R290
 Application LBP+MBP
 Voltage range 95-140V
 Starting torque HST
 Approvals UL
 CCC

Electrical accessories / wiring diagram

CSIR

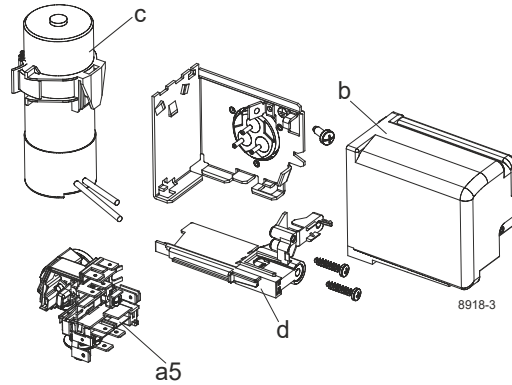

Ambient/ machine room temperatures minimum /maximum

Ambient temperature range: 10 - 43°C / 50 - 110°F
 Machine room temperature range: 10 - 48°C / 50 - 119°F
 Compressor cooling: fan 3m/s

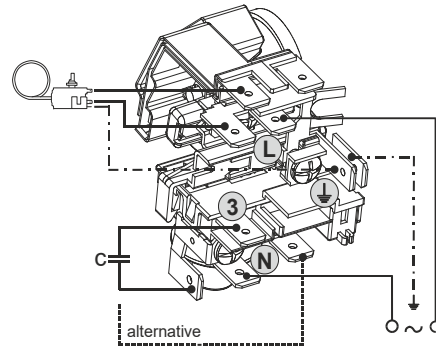

Operation pressure range

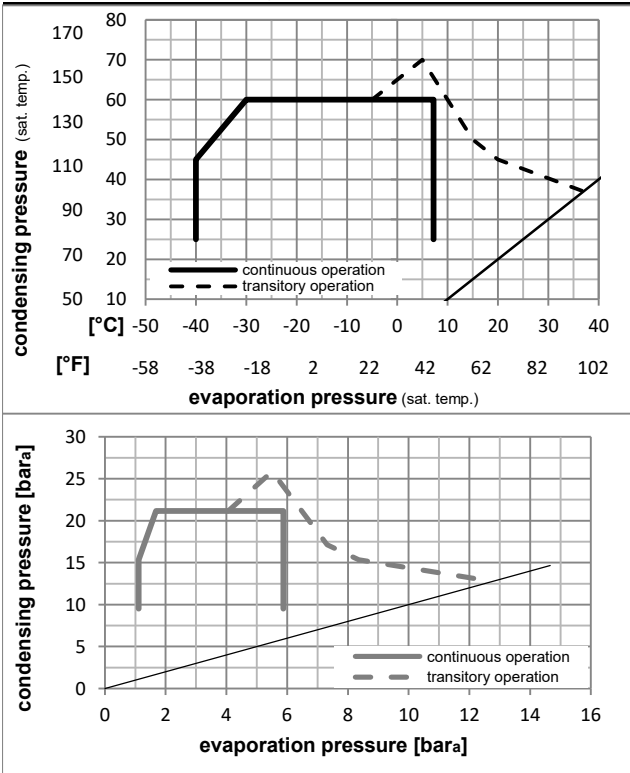

Components

- | | | |
|------|------------------------------------|----------|
| a5 | current relay (T1209/L6-S4) | 117U7074 |
| c | start capacitor (240µF) | 117U5002 |
| b, d | cover + clamp + screws(5VA-compl.) | 103N0600 |

Alternative components

- | | | |
|------|------------------------------------|----------|
| b, d | 100x cover + clamp + screws(5VA) | 103N2060 |
| b, d | cover + clamp + screws(5VA) in bag | 103N1060 |

Model

Designation **KLF4.0CNH** **115-127V/60Hz** Conf. 1 Sales code: **106H3408**

Optimization + standard conditions

R290, 115V/60Hz, CSIR, fan 3m/s, UL, CCC

	pe	pc	RGT	Tliq	W	[Btu/h]	[kcal/h]	COP	EER	[kcal/Wh]	P1	I	m	
	[°C]	[°C]	[°C]	[°C]	[W]	[Btu/h]	[kcal/h]	[W/W]	[Btu/Wh]	[kcal/Wh]	[W]	[A]	[kg/h]	
ASHRAE LBP	-23	54	32	32	228,0	779	196,2	1,49	5,08	1,28	153,2	1,92	2,31	
	[°F]	[°F]	[°F]	[°F]										
	-10	130	90	90										
cecomaf LBP	-25	55	32	55	169,4	579	145,8	1,14	3,89	0,98	148,7	1,89	2,11	
	[°F]	[°F]	[°F]	[°F]										
	-13	131	90	131										
EN12900 LBP	-35	40	20	40	127,2	434	109,5	1,05	3,58	0,90	121,3	1,73	1,45	
	[°F]	[°F]	[°F]	[°F]										
	-31	104	68	104										
ASHRAE MBP	-7	54	35	46	418,6	1429	360,2	2,09	7,14	1,80	200,3	2,25	4,77	
	[°F]	[°F]	[°F]	[°F]										
	20	130	95	115										
cecomaf MBP	-10	55	32	55	331,7	1133	285,5	1,72	5,88	1,48	192,8	2,20	4,20	
	[°F]	[°F]	[°F]	[°F]										
	14	131	90	131										
EN12900 MBP	-10	45	20	45	376,1	1284	323,7	2,14	7,30	1,84	175,9	2,07	4,62	
	[°F]	[°F]	[°F]	[°F]										
	14	113	68	113										

Performance tables

R290, 115V/60Hz, CSIR, fan 3m/s, UL, CCC

	pe	Cond. pressure	Cooling capacity			COP	EER			P1	I	m
	[°C]	[°F]	[W]	[Btu/h]	[kcal/h]	[W/W]	[Btu/Wh]	[kcal/Wh]	[W]	[A]	[kg/h]	
[°C / °F]	-34	-30	122,7	419	105,6	0,99	3,39	0,86	123,5	1,75	1,38	
cond. pressure	-34	-30	122,7	419	105,6	0,99	3,39	0,86	123,5	1,75	1,38	
pc= 45/113	-23	-10	222,9	761	191,8	1,52	5,20	1,31	146,3	1,88	2,52	
return gas temp.	-15	5	320,7	1095	276,0	1,94	6,63	1,67	165,2	2,00	3,65	
RGT= 32/90	-4	25	492,6	1682	423,9	2,63	8,98	2,26	187,3	2,15	5,68	
liquid temp	0	32	566,1	1933	487,2	2,93	10,02	2,52	193,0	2,20	6,57	
Tliq= 45/113	7,2	45	724,3	2473	623,3	3,63	12,41	3,13	199,4	2,24	8,51	
[°C / °F]	-34	-30	92,9	317	80,0	0,76	2,59	0,65	122,6	1,74	1,15	
cond. pressure	-34	-30	92,9	317	80,0	0,76	2,59	0,65	122,6	1,74	1,15	
pc= 55/131	-23	-10	184,6	630	158,9	1,20	4,10	1,03	153,7	1,93	2,30	
return gas temp	-15	5	270,4	924	232,7	1,51	5,17	1,30	178,6	2,09	3,40	
RGT= 32/90	-4	25	418,8	1430	360,4	2,01	6,87	1,73	208,3	2,31	5,34	
liquid temp	0	32	482,1	1646	414,9	2,23	7,60	1,92	216,6	2,37	6,19	
Tliq= 55/131	7,2	45	618,4	2112	532,2	2,72	9,27	2,34	227,7	2,46	8,06	

Model

Designation **KLF4.0CNH** **115-127V/60Hz** Conf. 2 Sales code: **106H3408**

Configuration

Motor configuration RSCR
 Power supply (nominal) 115-127V/60Hz 1~
 Refrigerant R290
 Application LBP+MBP
 Voltage range 95-140V
 Starting torque LST
 Approvals UL
 CCC

Electrical accessories / wiring diagram

RSCR

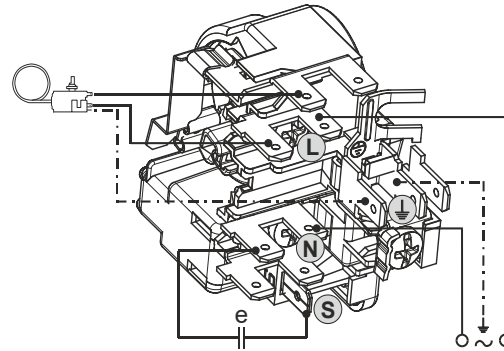
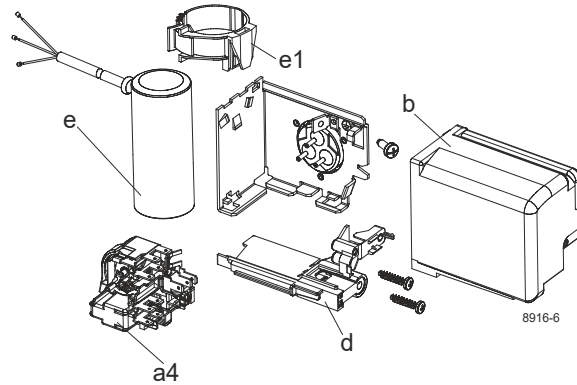

Ambient/ machine room temperatures minimum /maximum

Ambient temperature range: 10 - 43°C / 50 - 110°F

Machine room temperature range: 10 - 48°C / 50 - 119°F

Compressor cooling: fan 3m/s

Operation pressure range

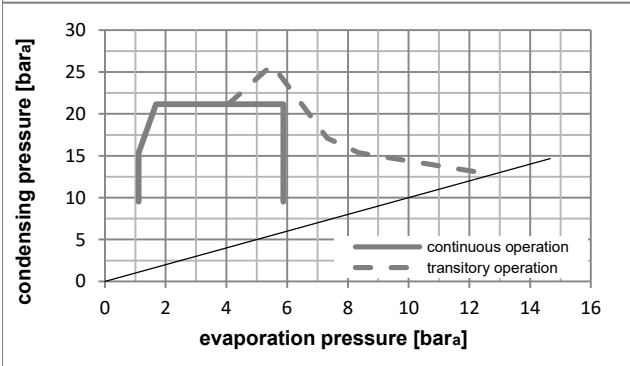
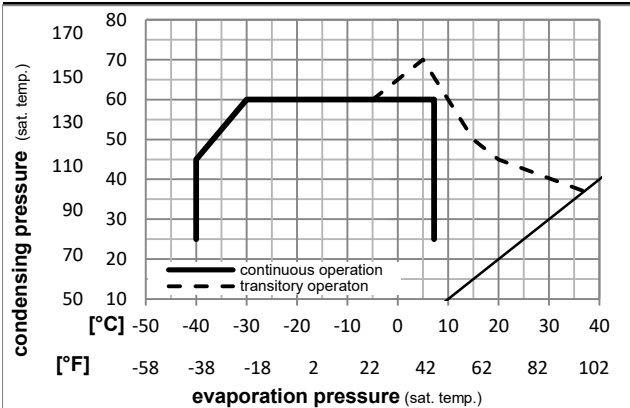

Components

a4	DLS4 (PTC,6.3mm, T1209/L6 - S4)	103N0210
e	run capacitor (15μF, 6,3mm)	117-7153
b, d	cover + clamp + screws(5VA-compl.)	103N0600
e1	retaining clamp	103N0535

Alternative components

b, d	100x cover + clamp + screws(5VA)	103N2060
b, d	cover + clamp + screws(5VA) in bag	103N1060

Model

Designation **KLF4.0CNH** **115-127V/60Hz** Conf. 2 Sales code: **106H3408**

Optimization + standard conditions

R290, 115V/60Hz, RSCR, fan 3m/s, UL, CCC

	Evaporating pressure (saturation temperature)				Condensing pressure (saturation temperature)			COP	EER	P1	Power consumption		Ref. mass flow	
	pe	pc	RGT	Tliq	W	[Btu/h]	[kcal/h]				I	m		
	[°C]	[°F]	[°C]	[°F]	[W]	[Btu/h]	[kcal/h]	[W/W]	[Btu/Wh]	[kcal/Wh]	[W]	[A]	[kg/h]	
ASHRAE LBP	-23	54	32	32	230,4	787	198,3	1,57	5,35	1,35	147,0	1,36	2,33	
	-10	130	90	90										
cecomaf LBP	-25	55	32	55	171,1	584	147,2	1,20	4,09	1,03	142,8	1,32	2,13	
	-13	131	90	131										
EN12900 LBP	-35	40	20	40	128,1	437	110,2	1,10	3,76	0,95	116,3	1,10	1,46	
	-31	104	68	104										
ASHRAE MBP	-7	54	35	46	423,7	1447	364,7	2,22	7,58	1,91	190,8	1,73	4,83	
	20	130	95	115										
cecomaf MBP	-10	55	32	55	335,8	1147	289,0	1,83	6,24	1,57	183,9	1,67	4,25	
	14	131	90	131										
EN12900 MBP	-10	45	20	45	379,9	1298	327,0	2,26	7,72	1,94	168,1	1,53	4,66	
	14	113	68	113										

Performance tables

R290, 115V/60Hz, RSCR, fan 3m/s, UL, CCC

	pe		Cooling capacity			COP	EER	P1	I	m	
	[°C]	[°F]	[W]	[Btu/h]	[kcal/h]	[W/W]	[Btu/Wh]	[kcal/Wh]	[W]	[A]	[kg/h]
[°C / °F]	-40	-40	82,7	282	71,2	0,75	2,56	0,65	110,1	1,05	0,92
cond. pressure	-34	-30	123,7	422	106,4	1,04	3,57	0,90	118,3	1,12	1,39
pc= 45/113	-23	-10	224,8	768	193,4	1,60	5,48	1,38	140,1	1,30	2,54
return gas temp.	-15	5	323,9	1106	278,7	2,05	7,00	1,76	158,0	1,45	3,68
RGT= 32/90	-4	25	497,6	1700	428,3	2,78	9,50	2,40	178,8	1,63	5,74
liquid temp	0	32	571,9	1953	492,2	3,10	10,60	2,67	184,2	1,67	6,63
Tliq= 45/113	7,2	45	731,1	2497	629,2	3,84	13,13	3,31	190,2	1,72	8,59
[°C / °F]	-40	-40	53,4	182	46,0	0,51	1,73	0,44	105,6	1,01	0,66
cond. pressure	-34	-30	93,6	320	80,5	0,79	2,71	0,68	118,0	1,11	1,16
pc= 55/131	-23	-10	186,5	637	160,5	1,26	4,32	1,09	147,5	1,36	2,33
return gas temp	-15	5	273,7	935	235,5	1,60	5,47	1,38	170,7	1,56	3,44
RGT= 32/90	-4	25	423,9	1448	364,8	2,14	7,31	1,84	198,1	1,79	5,41
liquid temp	0	32	487,8	1666	419,8	2,37	8,10	2,04	205,6	1,86	6,27
Tliq= 55/131	7,2	45	625,0	2134	537,9	2,90	9,91	2,50	215,3	1,94	8,14