

ULT - ready

Model

Designation	MN13UDULTM	220-240V/50Hz 1~	Sales code:	105M0840
-------------	-------------------	------------------	-------------	-----------------

Compressor design

Oil type	Polyolester	Refrigerant(s)	R170
Oil viscosity	32cST	Displacement	12,55cm ³ / 0,77cu.in
Oil quantity	300cm ³ / 10,1fl.oz	Compressors on pallet	80
Refr. charge - tech. limit	150g / 5,3oz		
Free gas volume comp.	2360cm ³ / 79,8fl.oz		
Weight	11,5kg / 25,4lbs		
Motor protection	1# internal		
Winding resistance main	5,64Ω (at 25°C)		
Winding resistance aux	8,49Ω (at 25°C)		
Max. winding temp.	125°C / 257°F		
Max. discharge temp.	130°C / 266°F		



General - Configurations with MN13UDULTM

	Conf. 1
Motorconfiguration	CSIR
Power supply (nominal)	220-240V/50Hz
Number of phases	1
Voltage range	198-254V
Approvals	CCC
Starting torque	HST
Note	ULT-ready. Compressor for low-temp-stage of cascade refrigeration systems.

Applications with MN13UDULTM

	Conf. 1
Refrigerant	R170
Application	LBP
System cooling	fan 3m/s
Hot gas defrost	-/-
Long interval pull down	-/-

Electrical data - Configurations with MN13UDULTM

	Conf. 1
Starting device type	relay
Run capacitor	-/-
Start capacitor	80μF
LRA (locked rotor amps / 4s)	12,5A
RLA (rated load amps / 1s)	2,56A
Cut in current	12,5A

Model

ULT - ready

Designation

MN13UDULTM

220-240V/50Hz 1~

Sales code:

105M0840

Compressor dimensions

Housing	A Height	203mm / 7,99in
	B Height	197mm / 7,76in
	C Length shell	205mm / 8,07in
	D Length w. cover	254mm / 10in
	E Width	166mm / 6,54in

Connectors		Suction	Discharge	Process
		X	Y	Z
Diameter	[mm]	øi 8,11-8,29	øi 6,11-6,29	øi 6,11-6,29
(i:inside, o:outside)	[in]	øi 0,32-0,33	øi 0,24-0,25	øi 0,24-0,25
Material		copper	copper	copper
Horizontal angle	±2°	0°	0°	0°
Vertical angle	±2°	15°	15°	155°
Position l/h/w	[mm]	132/69/56	94/99/86	-111/92/72
	[in]	5,2/2,7/2,2	3,7/3,9/3,4	-4,4/3,6/2,8
Straight tube l.	[mm]	12	12	12
	[in]	0,5	0,5	0,5

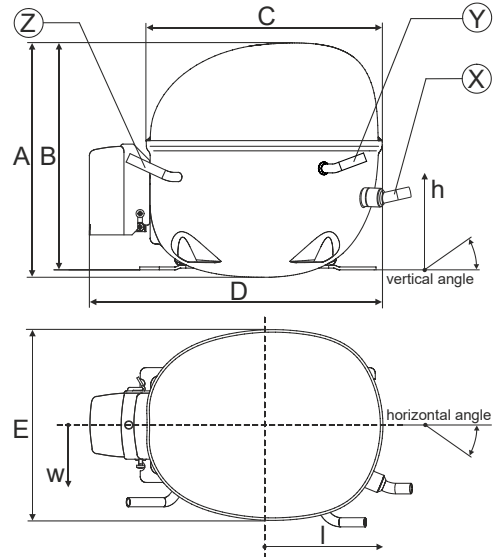

Compressor fixation

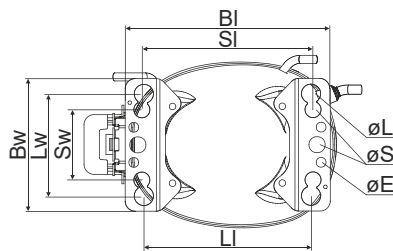

Baseplate	[mm]	[inch]
BI	204	8.03
BW	132	5.2
øE	ø 9.7	ø 0.38
Large holes	[mm]	[inch]
LI	165	6.5
LW	101.6	4
øL	ø 19	ø 0.75
Small holes	[mm]	[inch]
SI	170	6.7
SW	70	2.76
øS	ø 16	ø 0.63

Bolt joint

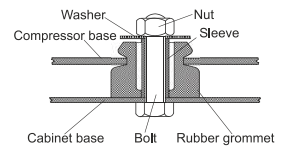

Snap-on

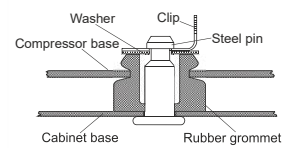

Mounting accessories

	one comp.	multi pack
Bolt joint M6 ø16mm	118-1917	118-1918
Bolt joint ø1/4" ø16mm	118-1946	
Bolt joint ø1/4" ø19mm	118-1949	
Snap-on ø7,3 ø16mm	118-1947	118-1919

Application notes

ULT-ready. Compressor for low-temp-stage of cascade refrigeration systems.

No warranty if compressor operated relevant time outside of published operation limits.

Contact SECOP-Sales to agree on warranty limits (depends on kind of application).

ULT - ready

Model

Designation **MN13UDULTM 220-240V/50Hz** Conf. 1 Sales code: **105M0840**

Configuration

Motorconfiguration	CSIR
Power supply (nominal)	220-240V/50Hz 1~
Refrigerant	R170
Application	LBP
Voltage range	198-254V
Starting torque	HST
Approvals	CCC

Electrical accessories / wiring diagram

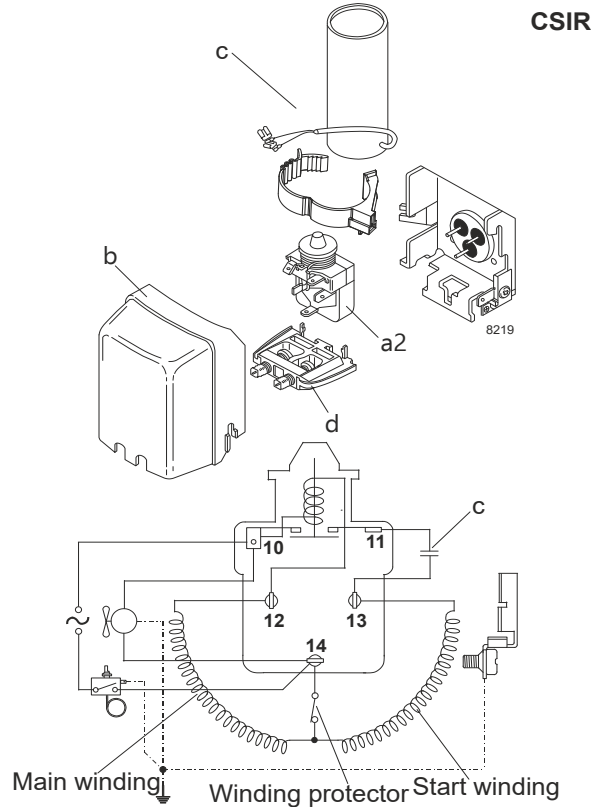

Ambient temperatures / system cooling

Ambient temperature min.: 10°C / 50°F
 Ambient temperature max.: 38°C / 101°F

System cooling (n/a: outside limits)			
T ambient	LBP	MBP	HBP
32°C / 90°F	fan 3m/s	n/a	n/a
38°C / 100°F	fan 3m/s	n/a	n/a
43°C / 110°F	n/a	n/a	n/a

Operation pressure range

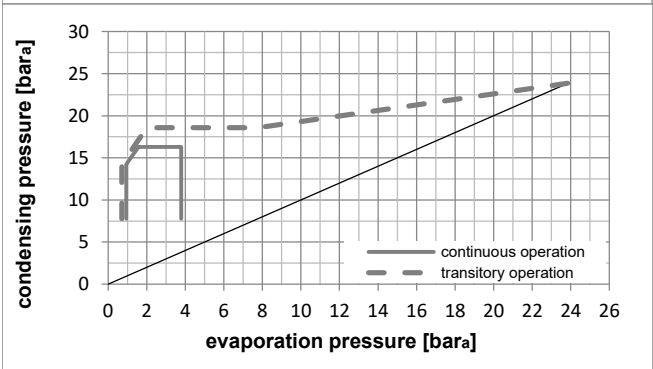
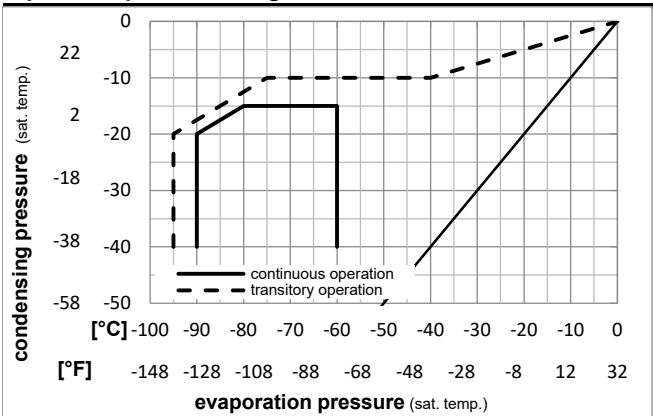

Components

a2	relay	117U7053
c	start capacitor (80µF)	117U5079
b	plastic cover	103N2011
d	cord relief	103N1010

ULT - ready

Model

Designation **MN13UDULTM 220-240V/50Hz** Conf. 1 Sales code: **105M0840**

Optimization + standard conditions

R170, 220V/50Hz, CSIR, fan 3m/s, CCC

Evaporating pressure (saturation temperature)					Condensing pressure (saturation temperature)					Power consumption				
				Return gas temp.						Current consumption		Ref. mass flow		
				Liquid temp.	Cooling capacity		COP	EER		P1	I	ṁ		
pe	pc	RGT	Tliq	[W]	[Btu/h]	[kcal/h]	[W/W]	[Btu/Wh]	[kcal/Wh]	[W]	[A]	[kg/h]		
[°C]	-90	-15	-20	-15	125,2	428	107,8	0,69	2,37	0,60	180,8	1,65	1,15	1
[°F]	-130	5	-4	5										
[°C]	-90	-20	-20	-20	149,3	510	128,5	0,88	3,00	0,76	169,9	1,63	1,31	2
[°F]	-130	-4	-4	-4										
[°C]	-90	-25	-20	-25	170,1	581	146,4	1,03	3,53	0,89	164,4	1,61	1,44	3
[°F]	-130	-13	-4	-13										
[°C]	-90	-30	-20	-30	188,9	645	162,6	1,16	3,98	1,00	162,2	1,61	1,55	4
[°F]	-130	-22	-4	-22										
[°C]	-90	-35	-20	-35	207,0	707	178,2	1,29	4,39	1,11	161,0	1,61	1,65	5
[°F]	-130	-31	-4	-31										
[°C]	-90	-40	-20	-40	225,7	771	194,3	1,42	4,86	1,23	158,6	1,61	1,74	6
[°F]	-130	-40	-4	-40										

Performance tables

R170, 220V/50Hz, CSIR, fan 3m/s, CCC

	pe	Cooling capacity			COP	EER		P1	I	m	
	[°C]	[°F]	[W]	[Btu/h]	[kcal/h]	[W/W]	[Btu/Wh]	[kcal/Wh]	[W]	[A]	[kg/h]
[°C / °F]	-90	-130	170,1	581	146,4	1,03	3,53	0,89	164,4	1,61	1,44
cond. pressure	-85	-121	250,3	855	215,4	1,27	4,34	1,09	197,0	1,68	2,13
pc= -25/-13	-80	-112	348,9	1192	300,3	1,50	5,13	1,29	232,3	1,77	2,97
return gas temp.	-75	-103	468,2	1599	403,0	1,74	5,95	1,50	268,6	1,87	4,00
RGT= -20/-4	-70	-94	610,7	2086	525,6	2,01	6,86	1,73	304,1	1,99	5,24
liquid temp	-65	-85	778,7	2659	670,2	2,31	7,89	1,99	337,2	2,10	6,71
Tliq= -25/-13	-60	-76	974,3	3328	838,5	2,66	9,09	2,29	366,2	2,20	8,43
[°C / °F]	-90	-130	207,0	707	178,2	1,29	4,39	1,11	161,0	1,61	1,65
cond. pressure	-85	-121	292,9	1000	252,1	1,55	5,29	1,33	189,0	1,67	2,33
pc= -35/-31	-80	-112	398,8	1362	343,2	1,84	6,29	1,58	216,7	1,73	3,18
return gas temp	-75	-103	527,2	1800	453,7	2,17	7,43	1,87	242,5	1,80	4,22
RGT= -20/-4	-70	-94	680,6	2324	585,7	2,57	8,78	2,21	264,6	1,86	5,46
liquid temp	-65	-85	861,2	2941	741,2	3,06	10,45	2,63	281,4	1,91	6,93
Tliq= -35/-31	-60	-76	1071,4	3659	922,0	3,68	12,57	3,17	291,2	1,94	8,66

Model

ULT - ready

Designation

MN13UDULTM 220-240V/50Hz

Sales code:

105M0840

Application note

This compressor is designed for operation inside the low-temperature-stage of a two stage refrigeration cascade. Use of various refrigerants and refrigerant-mixtures is possible but it must be ensured that the pressure limits shown on the pages before are not exceeded.

Operation outside of the published operation limits (pressures, temperatures, compressor cooling, voltage range) may lead to serious overloading of motor protector and starting equipment and must be avoided. In case of frequent overloading defects of relays, capacitors or motor protectors can occur.

To avoid overloading (or to keep it on the lowest possible level) adjust size of heat-exchangers, temperature of intercooler, and on-off control of compressors and fans.

Please also read design recommendations for ULT cabinets:

<https://www.secop.com/ult>

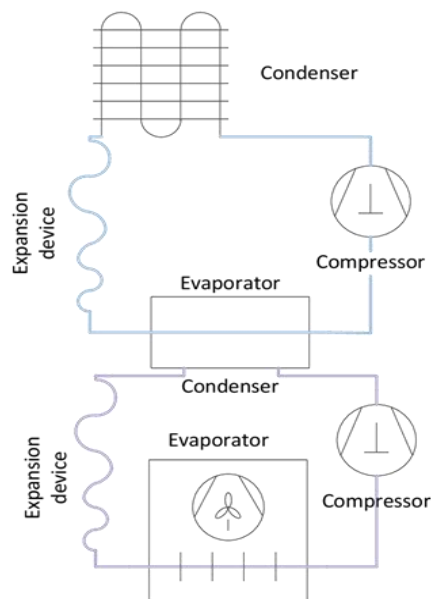

ULT - ready compressors

These compressors allow operation with various refrigerants. Chemical compatibility (UL) is proven for R170. Motor and motor-protector are adjusted for safe and reliable operation inside the published operation limits. Extra-robust starting equipment is used but unfortunate performance regulation of the high-temperature-stage may create serious overloading of the second stage during starting. Compressors are proven reliable by internal SECOP testing (running inside given operation limits).

Warranty

Since design and regulation-strategy of the two stage cascade significantly define overloading of the compressor in the low-temperature-stage SECOP can't give universal warranty. Conditional warranty can be given in cases of joined (cabinet producer & SECOP) testing and approval. No liability in case of design changes like: use of different oil, use of different starting equipment or motor protector. No warranty if operated relevant time outside of published operation limits.