

## Model

Designation	<b>MN13UVULTM</b>	Sales code:	<b>105M0853</b>
-------------	-------------------	-------------	-----------------

## Compressor design

Oil type	Polyolester	Refrigerant(s)	<b>R170, R290, R1270</b>
Oil viscosity	32cSt	Displacement	12,55cm <sup>3</sup> / 0,77cu.in
Oil quantity	320cm <sup>3</sup> / 10,8fl.oz	Compressors on pallet	80
Refr. charge - tech. limit	300g / 10,6oz		
Free gas volume comp.	2360cm <sup>3</sup> / 79,8fl.oz		
Weight	10,8kg / 23,8lbs		
Motor protection	2# internal		
Winding resist. ph. to ph.	5,3Ω (at 25°C)		
Max. winding temp.	125°C / 257°F		
Max. discharge temp.	130°C / 266°F		



Compressor for laboratory and medical applications.  
Check special warranty terms with Secop Sales.

## General - Configurations and Applications with MN13UVULTM and Controller

	<b>Conf. 1</b>	<b>Conf. 2</b>	<b>Conf. 3</b>	<b>Conf. 4</b>	<b>Conf. 5</b>
Sales code single pack:	105N4960	105N4960	105N4962	105N4962	105N4962
Sales code industry pack:	105N4961	105N4961	105N4963	105N4963	105N4963
Power supply (nominal)	100-240V,50/60Hz	100-240V,50/60Hz	100-240V,50/60Hz	100-240V,50/60Hz	100-240V,50/60Hz
Approvals	UL,VDE,CCC	UL,VDE,CCC	UL,VDE,CCC	UL,VDE,CCC	UL,VDE
Refrigerant	R290	R170	R290	R170	R1270
Number of phases	1~AC	1~AC	1~AC	1~AC	1~AC
Application	L+MBP	ULT	L+MBP	ULT	LBP
Starting torque	HST	HST	HST	HST	HST
Hot gas defrost	OK	OK	OK	OK	OK
Long interval pull down	OK	-/-	OK	-/-	-/-
System cooling	Fan cooling 3m/s	Fan cooling 3m/s	Fan cooling 3m/s	Fan cooling 3m/s	Fan cooling 3m/s
Note	- / -				

## Controller functions

	<b>Conf. 1</b>	<b>Conf. 2</b>	<b>Conf. 3</b>	<b>Conf. 4</b>	<b>Conf. 5</b>
Protection	Mechanic	Mechanic	Mechanic	Mechanic	Mechanic
Max output power	1000W	1000W	1000W	1000W	1000W
No of relays	2	2	2	2	2
Hot gas defrost	yes	yes	yes	yes	yes
AEO speed setting	yes	yes	yes	yes	yes
Serial com, (Modbus)	SWI	SWI	SWI	SWI	SWI
DWI / Frequency input	yes	yes	yes	yes	yes
Note			Low touch current	Low touch current	Low touch current

## Model

Designation

**MN13UVULTM**

Sales code:

**105M0853**

## Compressor dimensions

<b>Housing</b>	A Height	203mm / 7,99in
	B Height	197mm / 7,76in
	C Length shell	205mm / 8,07in
	D Length w. cover	252mm / 9,92in
	E Width	166mm / 6,54in

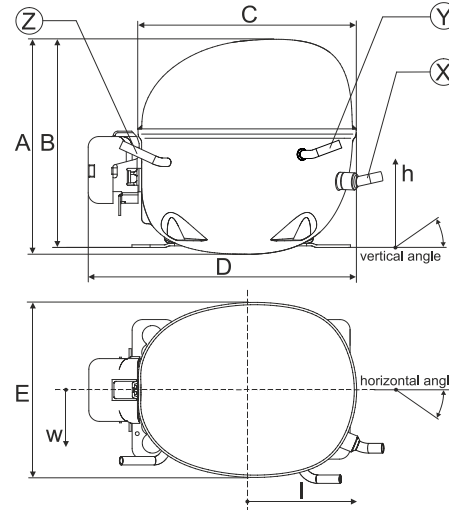

Connectors		Suction	Discharge	Process
		X	Y	Z
Diameter	[mm]	øi 8,11-8,29	øi 6,41-6,59	øi 6,41-6,59
(i:inside, o:outside)	[in]	øi 0,32-0,33	øi 0,25-0,26	øi 0,25-0,26
Material		copper	copper	copper
Horizontal angle	±2°	0°	0°	0°
Vertical angle	±2°	15°	21°	155°
Position l/h/w	[mm]	132/69/57	94/102/81	-109/94/72
	[in]	5,2/2,7/2,2	3,7/4/3,2	-4,3/3,7/2,8
Straight tube l.	[mm]	12	12	12
	[in]	0,5	0,5	0,5

## Compressor fixation

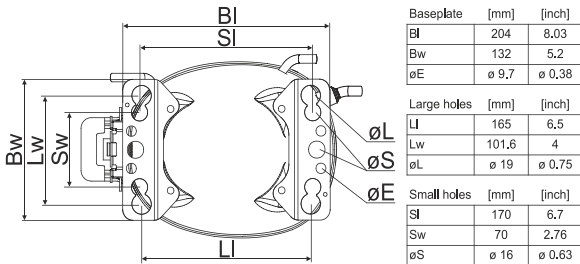

### Bolt joint

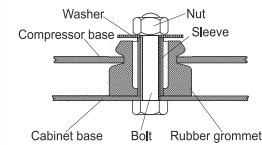

### Snap-on

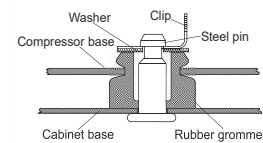

Mounting accessories	one comp.	multi pack
Bolt joint   M6   ø16mm	118-1917	118-1918
Bolt joint   ø1/4"   ø16mm	118-1946	
Bolt joint   ø1/4"   ø19mm	118-1949	
Snap-on   ø7,3   ø16mm	118-1947	118-1919

## Application notes

Provision for PE Grounding is located at the PE Stamp on the compressor

Direct suction intake with telescope

QR Code and Hyperlink leads to the

[Operating Instructions.](#)



## Model

Designation	<b>MN13UVULTM</b>	<b>100-240V,50/60Hz</b>	<b>Conf. 1</b>	Sales code:	<b>105M0853</b>
Controller	<b>NLV MP MV</b>				<b>105N4960</b>

Sales code single pack:	105N4960 (1 units)
Sales code industry pack:	105N4961 (8 units)
Adaption to compressor:	detached
Protection class:	IP54
Weight:	1,4kg/3,08lbs
Voltage nom.:	100-240V,50/60Hz
Voltage range:	90-150/180-270V
Max. current:	4,2A(230V)/8,4A(115V)
LRA (Locked Rotor Amperage):	1,2A
Cable length:	680mm
Compressor speed range:	2000-4500rpm
Housing plastic:	UL94-5VA

### Controller dimensions:

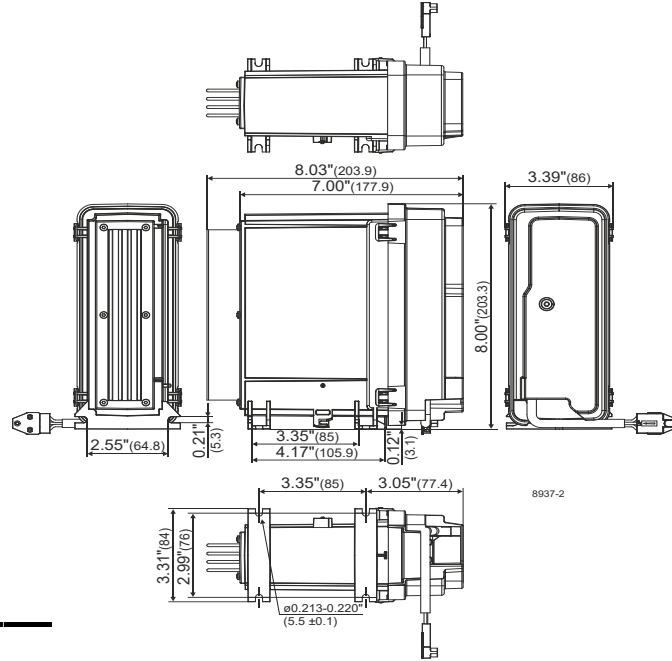

## Operation Limits

Suctiongas temperature < +20°C (continuous operation)

## System cooling

### Ambient/ machineroom temperatures minimum /maximum

Ambient temperature range:	10 - 43°C / 50 - 110°F
Machine room temperature range compressor:	10 - 48°C / 50 - 119°F
Machine room temperature range controller:	10 - 50°C / 50 - 122°F

### Compressor and Controller Cooling:

Fan cooling 3m/s

Ensure proper airflow of 3 m/s at both compressor and electronic units.  
The airflow for the electronics must be directed to the heat sink.

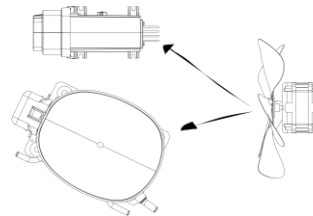

## Operation pressure range

R290

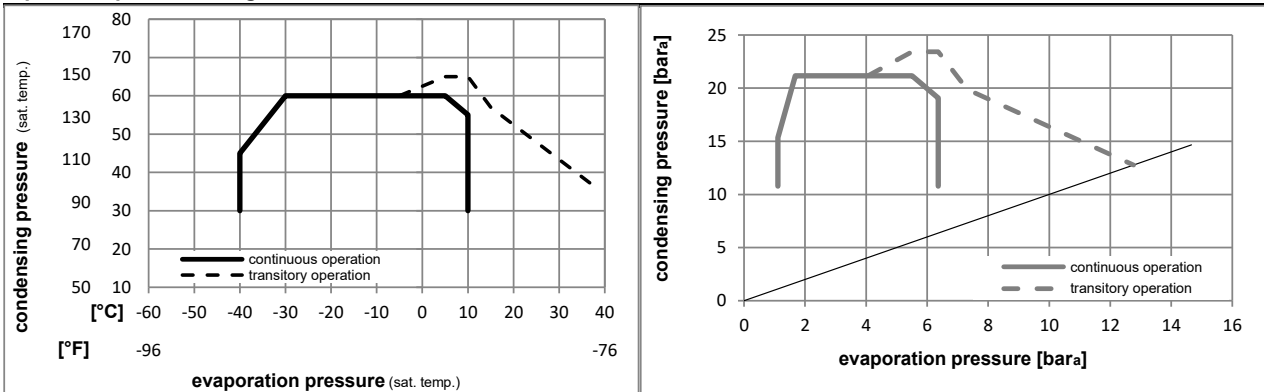

## Model

Designation **MN13UVULTM 100-240V,50/60Hz Conf. 2** Sales code: **105M0853**

Controller **NLV MP MV** **105N4960**

Sales code single pack: 105N4960 (1 units)  
 Sales code industry pack: 105N4961 (8 units)  
 Adaption to compressor: detached  
 Protection class: IP54  
 Weight: 1,4kg/3,08lbs  
 Voltage nom.: 100-240V,50/60Hz  
 Voltage range: 90-150/180-270V  
 Max. current: 4,2A(230V)/8,4A(115V)  
 LRA (Locked Rotor Amperage) 1,2A  
 Cable length: 680mm  
 Compressor speed range: 2000-4500rpm  
 Housing plastic: UL94-5VA

### Controller dimensions:

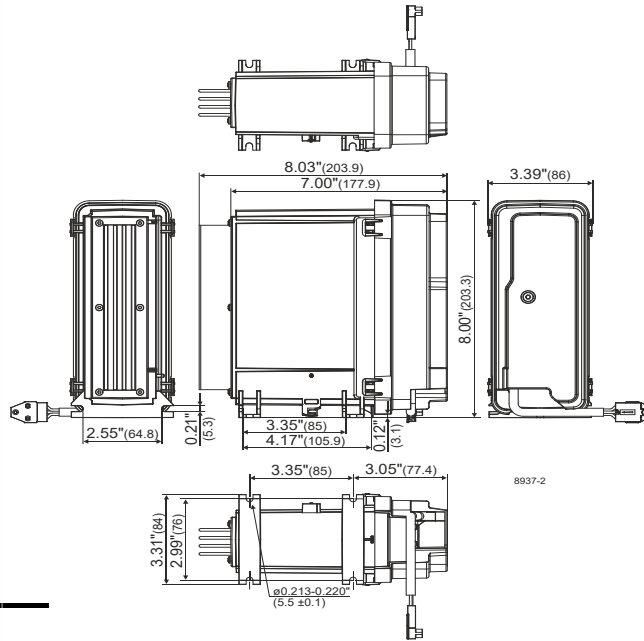

## Operation Limits

Suctiongas temperature < +20°C (continous operation)

## System cooling

### Ambient/ machineroom temperatures minimum /maximum

Ambient temperature range: 10 - 38°C / 50 - 101°F  
 Machine room temperature range compressor: 10 - 43°C / 50 - 110°F  
 Machine room temperature range controller: 10 - 50°C / 50 - 122°F

**Compressor and Controller Cooling:** Fan cooling 3m/s

Ensure proper airflow of 3 m/s at both compressor and electronic units.  
 The airflow for the electronics must be directed to the heat sink.

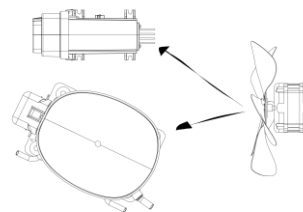

## Operation pressure range

R170

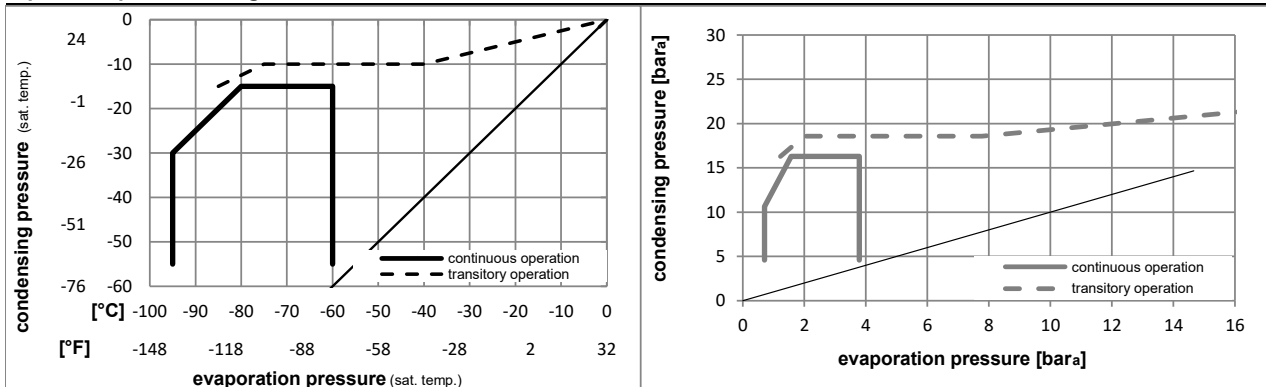

## Model

Designation **MN13UVULTM 100-240V,50/60Hz Conf. 3** Sales code: **105M0853**

Controller **NLV MP MV GFCI** **105N4962**

Sales code single pack: 105N4962 (1 units)

Controller dimensions:

Sales code industry pack: 105N4963 (8 units)

Adaption to compressor: detached

Protection class: IP54

Weight: 1,4kg/3,08lbs

Voltage nom. 100-240V,50/60Hz

Voltage range 90-150/180-270V

Max. current: 4,2A(230V)/8,4A(115V)

LRA (Locked Rotor Amperage) 1,2A

Cable length: 915mm

Compressor speed range: 2000-4500rpm

Housing plastic: UL94-5VA

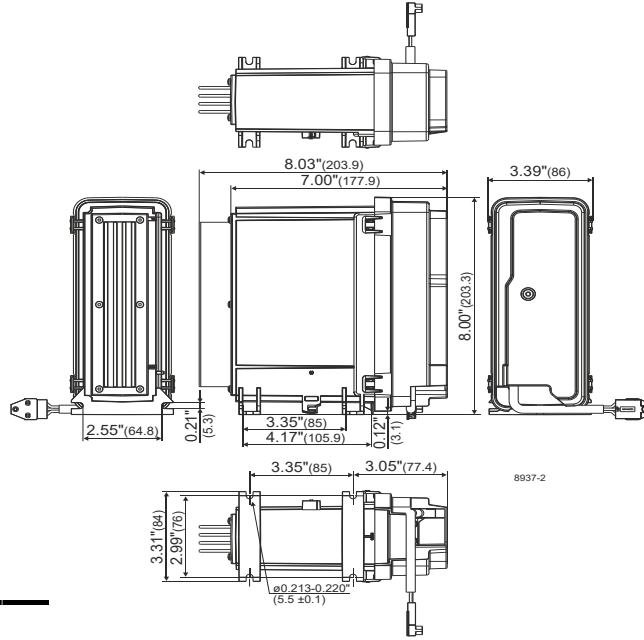

## Operation Limits

Suctiongas temperature < +20°C (continous operation)

## System cooling

Ambient/ machineroom temperatures minimum /maximum

Ambient temperature range: 10 - 43°C / 50 - 110°F

Machine room temperature range compressor: 10 - 48°C / 50 - 119°F

Machine room temperature range controller: 10 - 50°C / 50 - 122°F

Compressor and Controller Cooling: Fan cooling 3m/s

Ensure proper airflow of 3 m/s at both compressor and electronic units.

The airflow for the electronics must be directed to the heat sink.

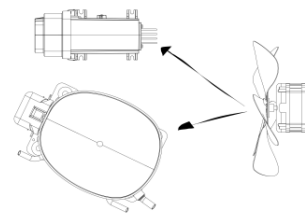

## Operation pressure range

R290

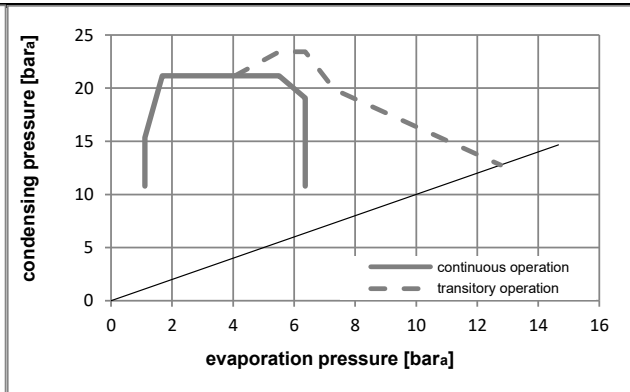
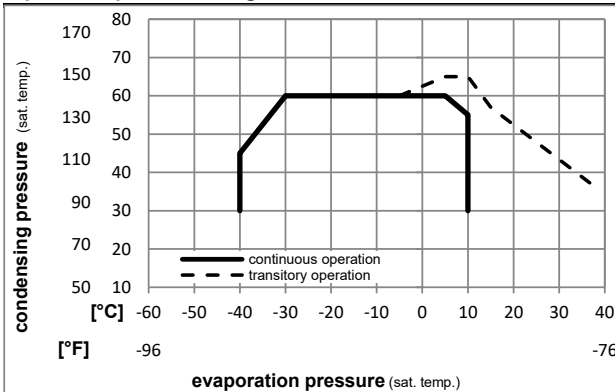

## Model

Designation **MN13UVULTM 100-240V,50/60Hz Conf. 4** Sales code: **105M0853**

Controller **NLV MP MV GFCI** **105N4962**

Sales code single pack: 105N4962 (1 units)

### Controller dimensions:

Sales code industry pack: 105N4963 (8 units)

Adaption to compressor: detached

Protection class: IP54

Weight: 1,4kg/3,08lbs

Voltage nom. 100-240V,50/60Hz

Voltage range 90-150/180-270V

Max. current: 4,2A(230V)/8,4A(115V)

LRA (Locked Rotor Amperage) 1,2A

Cable length: 915mm

Compressor speed range: 2000-4500rpm

Housing plastic: UL94-5VA

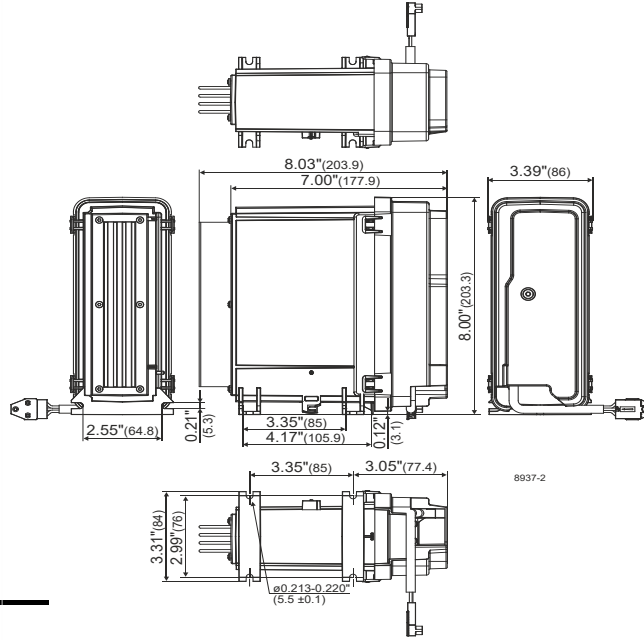

## Operation Limits

Suctiongas temperature < +20°C (continous operation)

## System cooling

### Ambient/ machineroom temperatures minimum /maximum

Ambient temperature range: 10 - 38°C / 50 - 101°F

Machine room temperature range compressor: 10 - 43°C / 50 - 110°F

Machine room temperature range controller: 10 - 50°C / 50 - 122°F

**Compressor and Controller Cooling:** Fan cooling 3m/s

Ensure proper airflow of 3 m/s at both compressor and electronic units.

The airflow for the electronics must be directed to the heat sink.

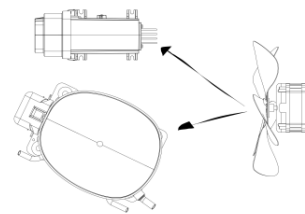

## Operation pressure range

R170

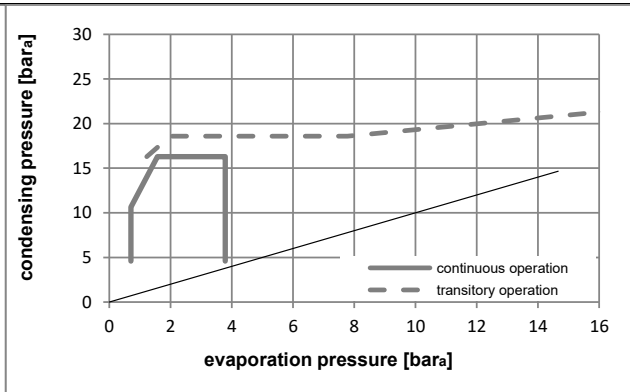
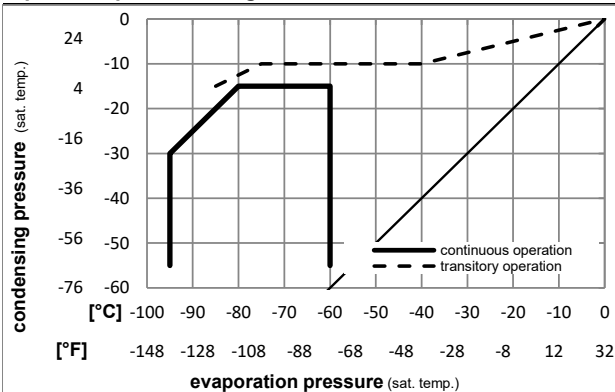

## Model

Designation **MN13UVULTM 100-240V,50/60Hz Conf. 5** Sales code: **105M0853**

Controller **NLV MP MV GFCI** **105N4962**

Sales code single pack: 105N4962 (1 units)  
 Sales code industry pack: 105N4963 (8 units)  
 Adaption to compressor: detached  
 Protection class: IP54  
 Weight: 1,4kg/3,08lbs  
 Voltage nom. 100-240V,50/60Hz1~AC  
 Voltage range 90-150/180-270V  
 Max, current: 4,2A(230V)/8,4A(115V)  
 LRA (Locked Rotor Amperage) 1,2A  
 Cable length: 915mm  
 Compressor speed range: 2000-4500rpm  
 Housing plastic: UL94-5VA

### Controller dimensions:

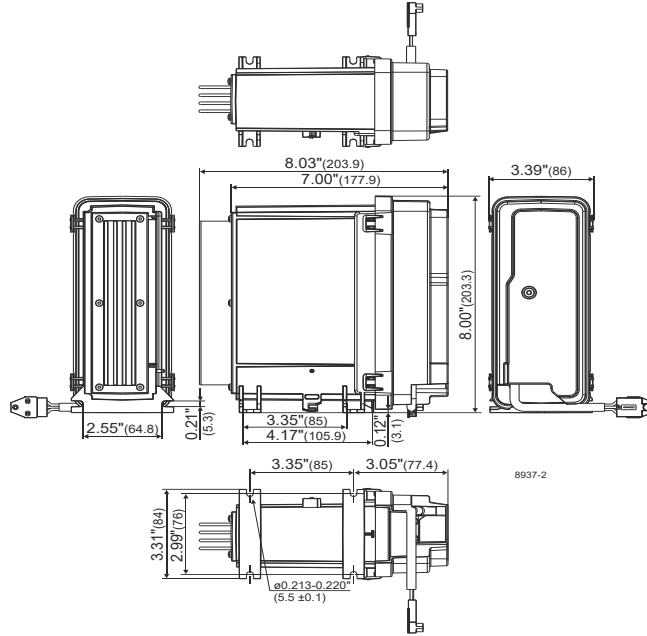

## Operation Limits

Suctiongas temperature < +20°C (continous operation)

## System cooling

### Ambient/ machineroom temperatures minimum /maximum

Ambient temperature range: 10 - 38°C / 50 - 101°F  
 Machine room temperature range compressor: 10 - 43°C / 50 - 110°F  
 Machine room temperature range controller: 10 - 50°C / 50 - 122°F

**Compressor and Controller Cooling:** Fan cooling 3m/s

Ensure proper airflow of 3 m/s at both compressor and electronic units.  
 The airflow for the electronics must be directed to the heat sink.

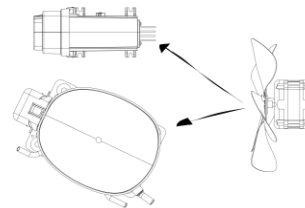

## Operation pressure range

R1270

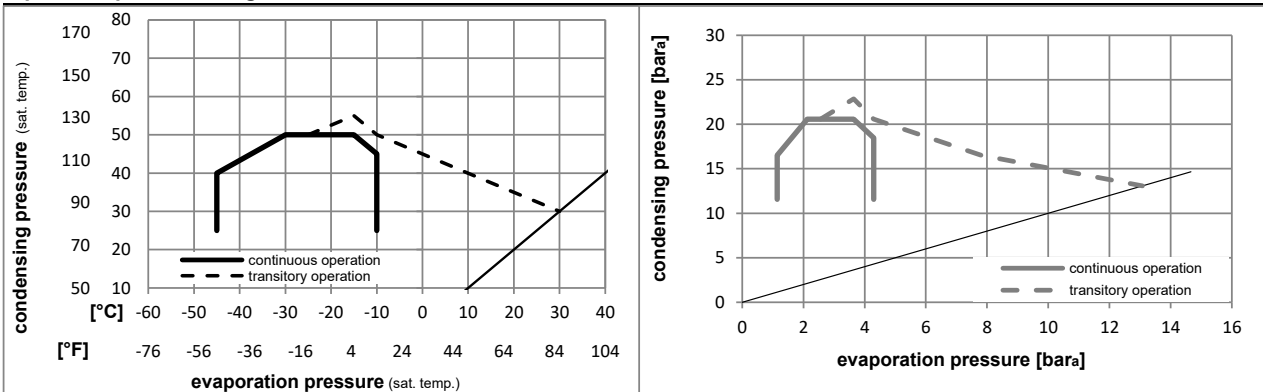

### Model

Designation **MN13UVULTM** 100-240V,50/60Hz Conf. 1,2,3,4,5 Sales code: **105M0853**

### Controller

**105N4960,105N4962**

### Controller connections

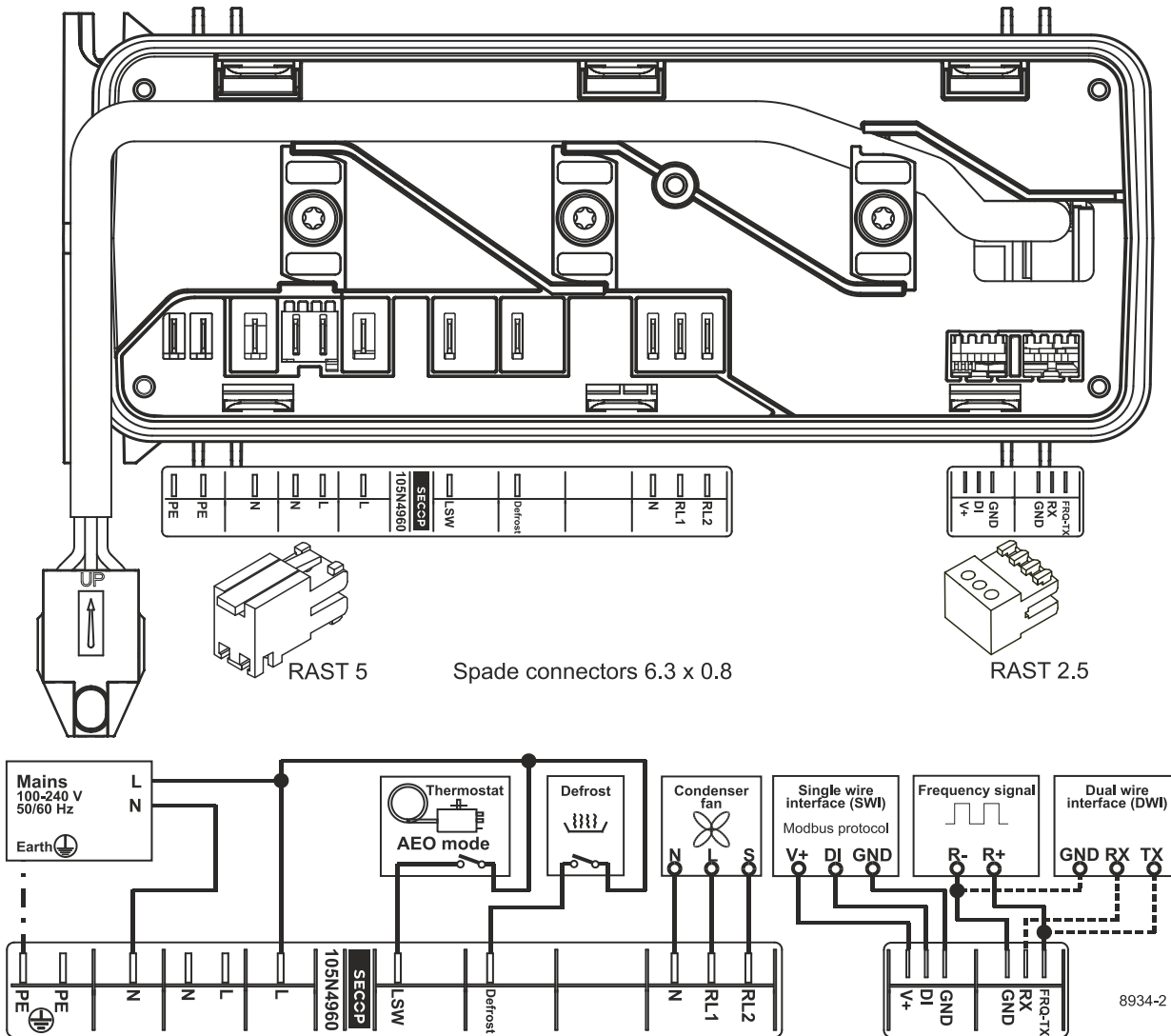

### Accessories (Compressor + Controller) - check operation manual for details

103N2008 plastic cover 1 pcs

### Model

Designation **MN13UVULTM 100-240V,50/60Hz Conf. 1,3** Sales code: **105M0853**

Controller **105N4960.105N4962**

### Optimization + standard conditions

R290, 240V, 50Hz, Rpm\_N 4500, Fan cooling 3m/s

	Evaporating pressure (saturation temperature)				Condensing pressure (saturation temperature)			Return gas temp.			Liquid temp.			Cooling capacity			COP	EER	Power consumption			ASHRAE LBP		
	pe	pc	RGT	Tliq	[W]	[Btu/h]	[kcal/h]	[W/W]	[Btu/Wh]	[kcal/Wh]	P1	I	m	[W]	[A]	[kg/h]								
[°C]	-23	54	32	32	1020,1	3484	877,9	1,80	6,15	1,55	566,1	2,42	10,33											
[°F]	-10	130	90	90																				
[°C]	-25	55	32	55	766,9	2619	660,0	1,41	4,83	1,22	542,3	2,32	9,55									CECOMAF LBP		
[°F]	-13	131	90	131																				
[°C]	-35	40	20	40	563,8	1925	485,2	1,49	5,10	1,29	377,3	1,64	6,44										EN12900 LBP	
[°F]	-31	104	68	104																				
[°C]	-7	54	35	46	1774,5	6060	1527,2	2,12	7,25	1,83	835,5	3,56	20,24										ASHRAE MBP	
[°F]	20	130	95	115																				
[°C]	-10	55	32	55	1419,4	4847	1221,5	1,81	6,19	1,56	782,8	3,33	17,95											CECOMAF MBP
[°F]	14	131	90	131																				
[°C]	-10	45	20	45	1538,1	5253	1323,7	2,13	7,29	1,84	720,5	3,07	18,88											EN12900 MBP
[°F]	14	113	68	113																				

### Standard conditions with different RPM

R290, 240V, 50Hz, Fan cooling 3m/s

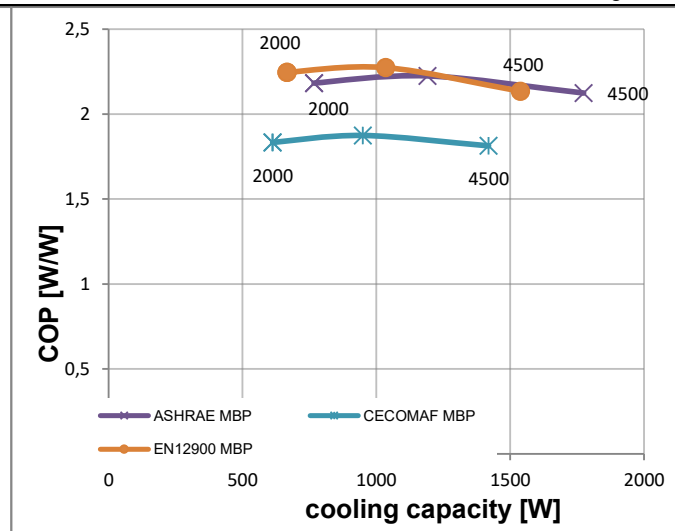
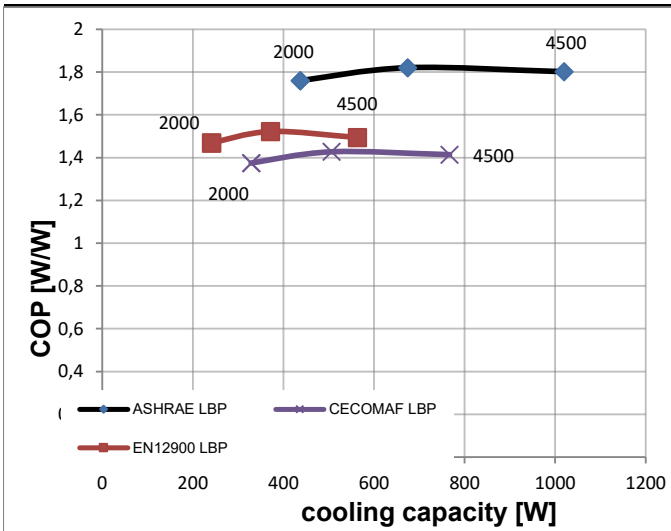

Test conditions:	pe [°C]	pc [°C]	Tliq [°C]	Tsuc [°C]	pe [°C]	pc [°C]	Tliq [°C]	Tsuc [°C]	
ASHRAE LBP	-23	54,44	32,22	32,22	ASHRAE MBP	-6,66	54,44	46,11	35
CECOMAF LBP	-25	55	55	32	CECOMAF MBP	-10	55	55	32
EN12900 LBP	-35	40	40	20	EN12900 MBP	-10	45	45	20

### Model

Designation **MN13UVULTM 100-240V,50/60Hz Conf. 2,4** Sales code: **105M0853**

Controller **105N4960,105N4962**

### Optimization + standard conditions

R170, 240V, 50Hz, Rpm\_N 4500, Fan cooling 3m/s

	Evaporating pressure (saturation temperature)				Condensing pressure (saturation temperature)			Return gas temp.			Liquid temp.			Cooling capacity			COP			EER			Power consumption			Ref. mass flow	
	pe	pc	RGT	Tliq	[W]	[Btu/h]	[kcal/h]	[W/W]	[Btu/Wh]	[kcal/Wh]	P1	I	m	[W]	[A]	[kg/h]											
[°C]	-85	-35	10	-15	472,3	1613	406,5	1,58	5,39	1,36	299,1	1,32	3,84	ULT 1													
[°F]	-121	-31	50	5																							
[°C]	-85	-40	10	-20	500,2	1708	430,5	1,78	6,08	1,53	281,2	1,24	3,93	ULT 2													
[°F]	-121	-40	50	-4																							
[°C]	-85	-45	10	-25	526,5	1798	453,1	2,03	6,92	1,74	259,8	1,16	4,01	ULT 3													
[°F]	-121	-49	50	-13																							
[°C]	-95	-35	10	-30	261,7	894	225,3	1,28	4,37	1,10	204,3	0,94	1,93	ULT 4													
[°F]	-139	-31	50	-22																							
[°C]	-95	-40	10	-35	285,9	977	246,1	1,45	4,94	1,25	197,5	0,92	2,05	ULT 5													
[°F]	-139	-40	50	-31																							
[°C]	-95	-45	10	-40	308,6	1054	265,6	1,64	5,61	1,41	187,9	0,88	2,15	ULT 6													
[°F]	-139	-49	50	-40																							

### Standard conditions with different RPM

R170, 240V, 50Hz, Fan cooling 3m/s

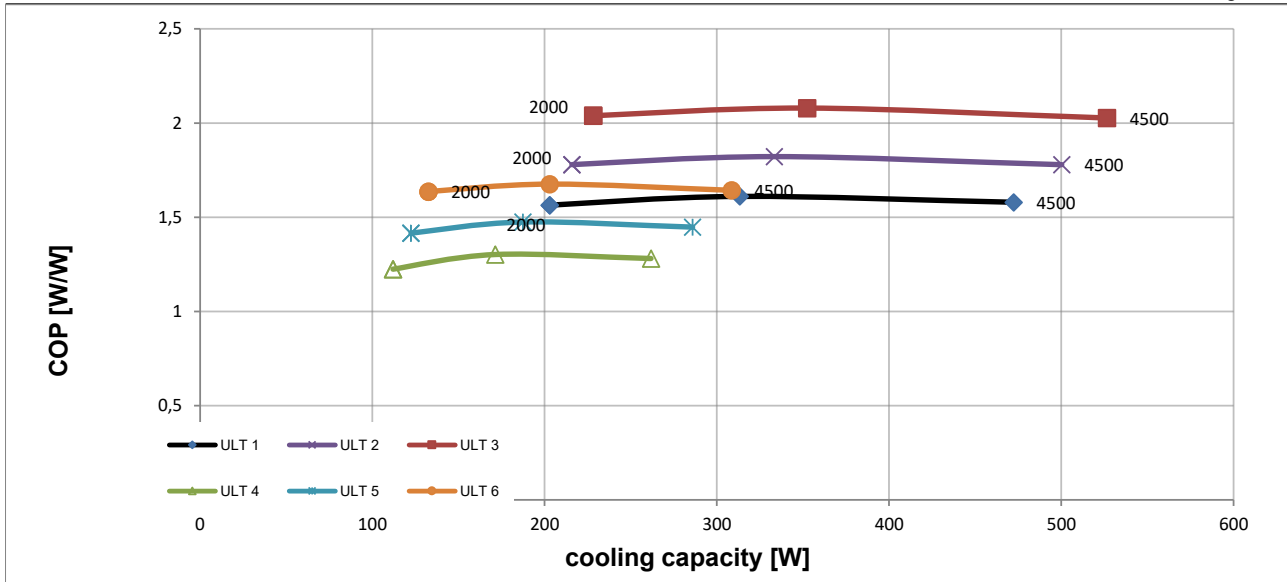

Test conditions:	pe [°C]	pc [°C]	Tliq [°C]	Tsuc [°C]
ULT 1	-85	-35	-15	10
ULT 2	-85	-40	-20	10
ULT 3	-85	-45	-25	10
ULT 4	-95	-35	-30	10
ULT 5	-95	-40	-35	10
ULT 6	-95	-45	-40	10

### Model

Designation **MN13UVULTM 100-240V,50/60Hz Conf. 5** Sales code: **105M0853**

Controller **NLV MP MV GFCI** **105N4962**

### Optimization + standard conditions

R1270, 240V, 50Hz, Rpm\_N 4500, Fan cooling 3m/s

	Evaporating pressure (saturation temperature)				Condensing pressure (saturation temperature)			COP	EER	Power consumption	Current consumption		Ref. mass flow	
	pe	pc	RGT	Tliq	[W]	[Btu/h]	[kcal/h]				P1	I		
	[°C]	[°C]	[°C]	[°C]	[W]	[Btu/h]	[kcal/h]	[W/W]	[Btu/Wh]	[kcal/Wh]	[W]	[A]	[kg/h]	
ASHRAE LBP	-23	54	32	32	1210,7	4135	1042,0	1,67	5,69	1,44	726,1	3,09	12,23	
CECOMAF LBP	-25	55	32	55	914,5	3123	787,0	1,31	4,47	1,13	698,4	2,98	11,32	
EN12900 LBP	-35	40	20	40	683,8	2335	588,5	1,41	4,81	1,21	485,5	2,09	7,74	
ARI540 LBP	-23	49	4,4	49	989,9	3381	851,9	1,41	4,83	1,22	700,2	2,98	13,42	
AHAM LBP	-23	41	32	32	1268,8	4333	1091,9	1,93	6,58	1,66	658,3	2,81	12,81	
opt LBP	-25	45	32	45	1048,4	3581	902,3	1,60	5,47	1,38	654,2	2,79	11,77	
	[°F]	[°F]	[°F]	[°F]										

### Standard conditions with different RPM

R1270, 240V, 50Hz, Fan cooling 3m/s

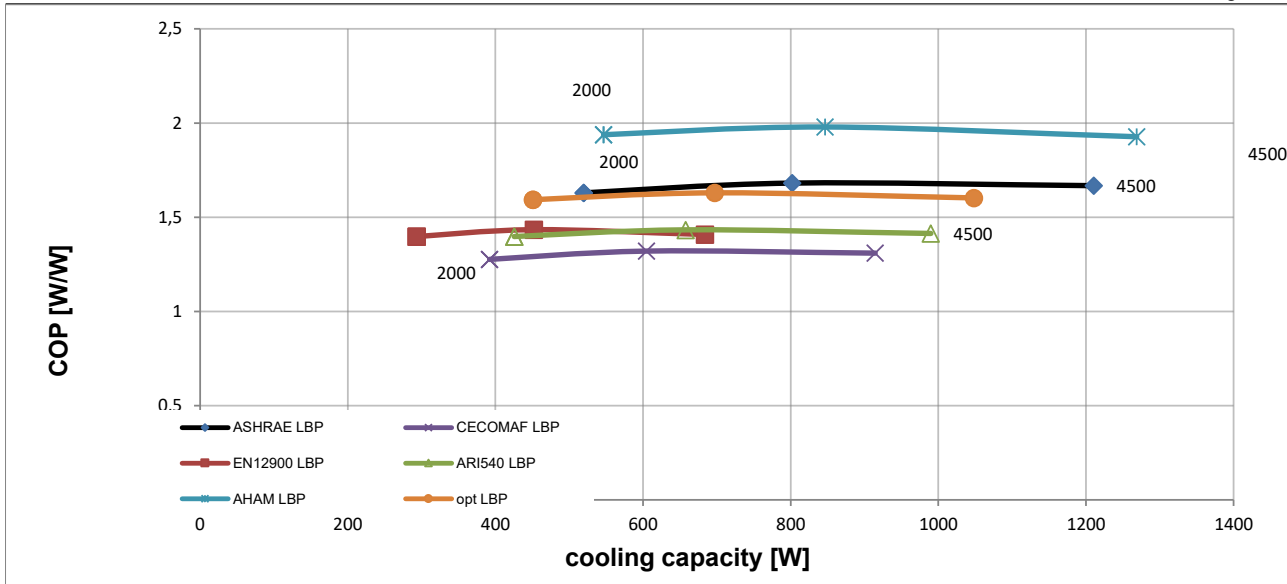

Test conditions:	pe [°C]	pc [°C]	Tliq [°C]	Tsuc [°C]
ASHRAE LBP	-23	54,44	32,22	32,22
CECOMAF LBP	-25	55	55	32
EN12900 LBP	-35	40	40	20
ARI540 LBP	-23	48,88	48,88	4,44
AHAM LBP	-23,333	40,6	32,22	32,22
opt LBP	-25	45	45	32