

ULT - ready

Model

Designation	MP2UVULTM	12-24V/DC	Sales code:	101M0800
-------------	------------------	------------------	-------------	-----------------

Compressor design

Oil type	Polyolester	Refrigerant(s)	R170, R508B
Oil viscosity	15cST	Displacement	2cm ³ / 0,12cu.in
Oil quantity	150cm ³ / 5,1fl.oz	Compressors on pallet	150
Refr. charge - tech. limit	300g / 10,6oz		
Free gas volume comp.	870cm ³ / 29,4fl.oz		
Weight	4,3kg / 9,5lbs		
Motor protection	external		
Winding resistance main	-/-		
Winding resistance aux	-/-		
Max. winding temp.	125°C / 257°F		
Max. discharge temp.	130°C / 266°F		



General - Configurations with MP2UVULTM

	with ULT controller
Motorconfiguration	BLPM
Power supply (nominal)	12-24V DC
Number of phases	1
Voltage range	9,6-31,5V
Approvals	UL
Starting torque	HST
Note	ULT-ready. Compressor for low-temp-stage of cascade refrigeration systems.

Applications with MP2UVULTM

	with ULT controller
Refrigerant	R170
Application	LBP
System cooling	static
Hot gas defrost	-/-
Long interval pull down	-/-
Mobile operation	OK

Electrical data - Configurations with MP2UVULTM

	with ULT controller
Starting device type	e-controller
Run capacitor	-/-
Start capacitor	-/-
LRA (locked rotor amps / 4s)	7A
RLA (rated load amps / 1s)	
Cut in current	

Model

ULT - ready

Designation

MP2UVULTM

12-24V/DC

Sales code:

101M0800

Compressor dimensions

Housing	A Height	137mm / 5,39in
	B Height	135mm / 5,31in
	C Length shell	176mm / 6,93in
	D Length w. cover	206mm / 8,11in
	E Width	130mm / 5,12in

Connectors		Suction	Discharge	Process
		X	Y	Z
Diameter	[mm]	øi 6,11-6,29	øi 5,12-5,26	øi 6,11-6,29
(i:inside, o:outside)	[in]	øi 0,24-0,25	øi 0,2-0,21	øi 0,24-0,25
Material		steel/CU	steel/CU	steel/CU
Horizontal angle	±2°	40°	0°	135°
Vertical angle	±2°	40°	21°	140°
Position l/h/w	[mm]	80/128/46	80/72/60	-47/125/50
	[in]	3,1/5/1,8	3,1/2,8/2,4	-1,9/4,9/2
Straight tube l.	[mm]	12	12	12
	[in]	0,5	0,5	0,5

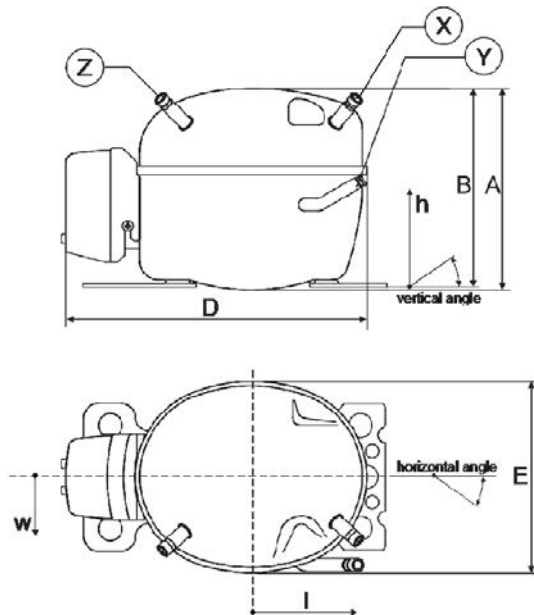

Compressor fixation

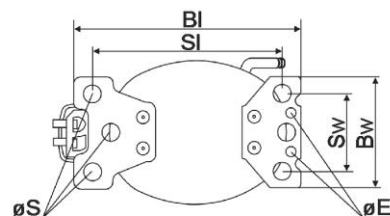

Baseplate	[mm]	[inch]
BI	204	8.03
Bw	100	3.94
øE	ø 9	ø 0.35
Small holes	[mm]	[inch]
SI	170	6.7
Sw	70	2.76
øS	ø 16	ø 0.63

Bolt joint

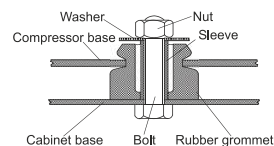

Snap-on

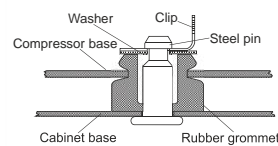

Mounting accessories

	one comp.	multi pack
Bolt joint M6 ø16mm	118-1917	118-1918
Bolt joint ø1/4" ø16mm	118-1946	
Snap-on ø7,3 ø16mm	118-1947	118-1919

Application notes

ULT-ready. Compressor for low-temp-stage of cascade refrigeration systems.

No warranty if compressor operated relevant time outside of published operation limits.

Contact SECOP-Sales to agree on warranty limits (depends on kind of application).

ULT - ready

Model					
Designation	MP2UVULTM	12-24V DC	Conf. 1	Sales code:	101M0800

Configuration

Motorconfiguration	BLPM
Power supply (nominal)	12-24V DC 1~
Refrigerant	R170
Application	LBP
Voltage range	9,6-31,5V
Starting torque	HST
Approvals	UL

Electrical accessories / wiring diagram

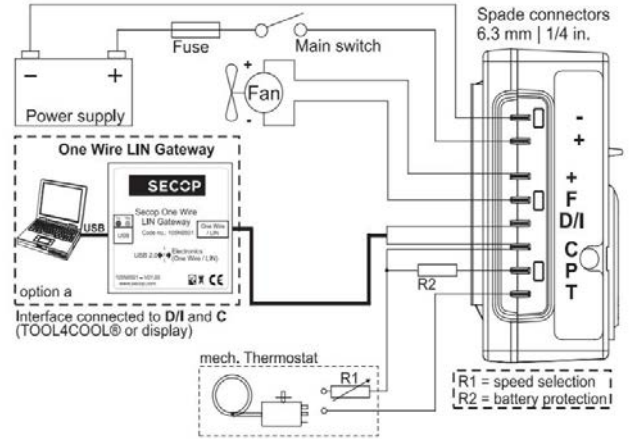

Ambient temperatures / system cooling

Ambient temperature min.:	10°C / 50°F
Ambient temperature max.:	43°C / 110°F

System cooling (n/a: outside limits)			
T ambient	LBP	MBP	HBP
32°C / 90°F	static	n/a	n/a
38°C / 100°F	static	n/a	n/a
43°C / 110°F	static	n/a	n/a

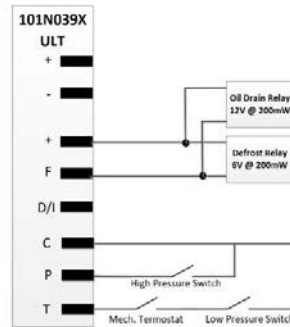

Operation pressure range

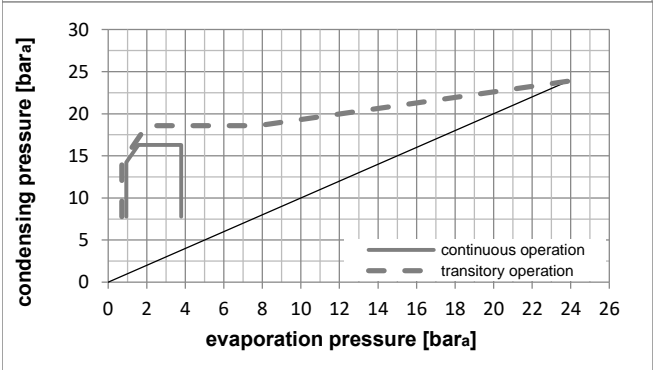
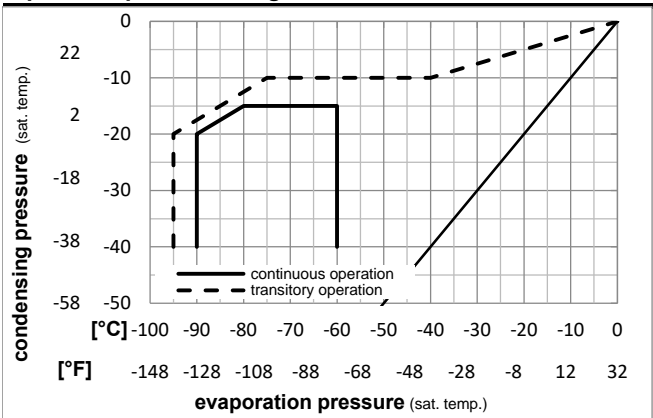

Components

ULT-Cabinet Controller 12/24V (Def. Valve) 101NULT1

ULT-Cabinet Controller 12/24V (Fan) 101NULT3

ULT - ready

Model

Designation **MP2UVULTM 12-24V DC** **2500rpm** Sales code: **101M0800**

Optimization + standard conditions

minimum speed, R170, 12V DC, BLPM, static, UL

Evaporating pressure (saturation temperature)					Condensing pressure (saturation temperature)						Power consumption			
					Return gas temp.						Current consumption			
					Liquid temp.						Ref. mass flow			
					Cooling capacity						COP EER			
pe	pc	RGT	Tliq	[W]	[Btu/h]	[kcal/h]	[W/W]	[Btu/Wh]	[kcal/Wh]	P1	I	m		
[°C]	[°C]	[°C]	[°C]							[W]	[A]	[kg/h]		
-90	-15	-20	-15	14,5	49	12,5	0,73	2,49	0,63	19,8	1,12	0,13		
[°F]	5	-4	5											
-130	-20	-20	-20	17,0	58	14,6	0,92	3,14	0,79	18,5	0,91	0,15		
[°F]	-4	-4	-4											
-90	-25	-20	-25	19,8	68	17,0	1,10	3,74	0,94	18,1	0,86	0,17		
[°F]	-13	-4	-13											
-130	-30	-20	-30	22,9	78	19,7	1,26	4,31	1,09	18,1	0,88	0,19		
[°F]	-22	-4	-22											
-90	-35	-20	-35	25,9	89	22,3	1,44	4,90	1,24	18,1	0,87	0,21		
[°F]	-31	-4	-31											
-130	-40	-20	-40	28,9	99	24,8	1,67	5,69	1,44	17,3	0,72	0,22		
[°F]	-40	-4	-40											

Performance tables

minimum speed, R170, 12V DC, BLPM, static, UL

	pe	Cooling capacity			COP	EER	P1	I	m		
	[°C]	[°F]	[W]	[Btu/h]	[kcal/h]	[W/W]	[Btu/Wh]	[kcal/Wh]	[W]	[A]	[kg/h]
[°C / °F]	-90	-130	19,8	68	17,0	1,10	3,74	0,94	18,1	0,86	0,17
cond. pressure	-85	-121	31,1	106	26,8	1,35	4,60	1,16	23,1	1,03	0,26
pc= -25/-13	-80	-112	45,6	156	39,2	1,61	5,50	1,39	28,3	1,21	0,39
return gas temp.	-75	-103	63,3	216	54,5	1,89	6,46	1,63	33,5	1,41	0,54
RGT= -20/-4	-70	-94	84,6	289	72,8	2,20	7,51	1,89	38,5	1,61	0,73
liquid temp	-65	-85	109,6	374	94,3	2,54	8,66	2,18	43,2	1,80	0,94
Tliq= -25/-13	-60	-76	138,5	473	119,2	2,92	9,96	2,51	47,5	1,99	1,20
[°C / °F]	-90	-130	25,9	89	22,3	1,44	4,90	1,24	18,1	0,87	0,21
cond. pressure	-85	-121	38,5	131	33,1	1,71	5,84	1,47	22,5	1,01	0,31
pc= -35/-31	-80	-112	54,1	185	46,5	2,03	6,92	1,74	26,7	1,16	0,43
return gas temp	-75	-103	73,0	249	62,8	2,39	8,15	2,05	30,6	1,30	0,58
RGT= -20/-4	-70	-94	95,5	326	82,2	2,81	9,59	2,42	34,0	1,43	0,77
liquid temp	-65	-85	121,7	416	104,7	3,31	11,30	2,85	36,8	1,55	0,98
Tliq= -35/-31	-60	-76	151,9	519	130,7	3,91	13,37	3,37	38,8	1,63	1,23

ULT - ready

Model

Designation **MP2UVULTM 12-24V DC** **4400rpm** Sales code: **101M0800**

Optimization + standard conditions

maximum speed, R170, 12V DC, BLPM, static, UL

Evaporating pressure (saturation temperature)					Condensing pressure (saturation temperature)						Power consumption						
					Return gas temp.			Liquid temp.			Cooling capacity		COP	EER	P1	I	Ref. mass flow
pe	pc	RGT	Tliq		[W]	[Btu/h]	[kcal/h]	[W/W]	[Btu/Wh]	[kcal/Wh]	[W]	[A]	[kg/h]				
[°C]	-90	-15	-20	-15	25,5	87	21,9	0,66	2,27	0,57	38,4	1,48	0,23	1			
[°F]	-130	5	-4	5													
[°C]	-90	-20	-20	-20	29,8	102	25,7	0,89	3,04	0,77	33,5	1,45	0,26	2			
[°F]	-130	-4	-4	-4													
[°C]	-90	-25	-20	-25	34,9	119	30,0	1,08	3,68	0,93	32,3	1,43	0,30	3			
[°F]	-130	-13	-4	-13													
[°C]	-90	-30	-20	-30	40,2	137	34,6	1,23	4,20	1,06	32,7	1,42	0,33	4			
[°F]	-130	-22	-4	-22													
[°C]	-90	-35	-20	-35	45,6	156	39,3	1,40	4,79	1,21	32,5	1,43	0,36	5			
[°F]	-130	-31	-4	-31													
[°C]	-90	-40	-20	-40	50,8	173	43,7	1,72	5,87	1,48	29,5	1,49	0,39	6			
[°F]	-130	-40	-4	-40													

Performance tables

maximum speed, R170, 12V DC, BLPM, static, UL

	pe		Cooling capacity			COP	EER	P1			I	m
	[°C]	[°F]	[W]	[Btu/h]	[kcal/h]	[W/W]	[Btu/Wh]	[kcal/Wh]	[W]	[A]	[kg/h]	
[°C / °F]	-90	-130	34,9	119	30,0	1,08	3,68	0,93	32,3	1,43	0,30	
cond. pressure	-85	-121	54,8	187	47,2	1,34	4,57	1,15	41,0	1,73	0,47	
pc= -25/-13	-80	-112	80,2	274	69,0	1,61	5,51	1,39	49,7	2,06	0,68	
return gas temp.	-75	-103	111,5	381	95,9	1,91	6,51	1,64	58,4	2,41	0,95	
RGT= -20/-4	-70	-94	148,9	509	128,1	2,22	7,60	1,91	66,9	2,77	1,28	
liquid temp	-65	-85	192,9	659	166,0	2,57	8,79	2,21	75,0	3,15	1,66	
Tliq= -25/-13	-60	-76	243,8	833	209,8	2,96	10,10	2,55	82,4	3,54	2,11	
[°C / °F]	-90	-130	45,6	156	39,3	1,40	4,79	1,21	32,5	1,43	0,36	
cond. pressure	-85	-121	67,7	231	58,2	1,69	5,76	1,45	40,2	1,73	0,54	
pc= -35/-31	-80	-112	95,2	325	81,9	2,01	6,87	1,73	47,3	2,00	0,76	
return gas temp	-75	-103	128,5	439	110,6	2,39	8,15	2,05	53,8	2,25	1,03	
RGT= -20/-4	-70	-94	168,1	574	144,6	2,83	9,65	2,43	59,5	2,46	1,35	
liquid temp	-65	-85	214,2	732	184,4	3,34	11,42	2,88	64,1	2,64	1,72	
Tliq= -35/-31	-60	-76	267,3	913	230,0	3,97	13,54	3,41	67,4	2,78	2,16	

ULT - ready

Model

Designation

MP2UVULTM 12-24V DC

Sales code:

101M0800

Application note

This compressor is designed for operation inside the low-temperature-stage of a two stage refrigeration cascade. Use of various refrigerants and refrigerant-mixtures is possible but it must be ensured that the pressure limits shown on the pages before are not exceeded.

Operation outside of the published operation limits (pressures, temperatures, compressor cooling, voltage range) may lead to serious overloading of motor protector and starting equipment and must be avoided. In case of frequent overloading defects of relays, capacitors or motor protectors can occur.

To avoid overloading (or to keep it on the lowest possible level) adjust size of heat-exchangers, temperature of intercooler, and on-off control of compressors and fans.

Please also read design recommendations for ULT cabinets:

<https://www.secop.com/ult>

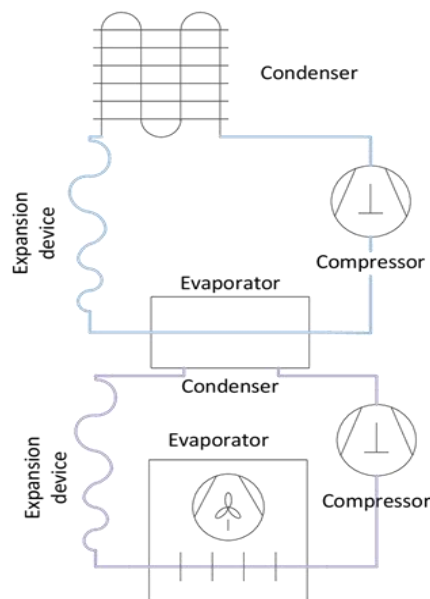

ULT - ready compressors

These compressors allow operation with various refrigerants. Chemical compatibility (UL) is proven for R170. Motor and motor-protector are adjusted for safe and reliable operation inside the published operation limits. Extra-robust starting equipment is used but unfortunate performance regulation of the high-temperature-stage may create serious overloading of the second stage during starting. Compressors are proven reliable by internal SECOP testing (running inside given operation limits).

Warranty

Since design and regulation-strategy of the two stage cascade significantly define overloading of the compressor in the low-temperature-stage SECOP can't give universal warranty. Conditional warranty can be given in cases of joined (cabinet producer & SECOP) testing and approval. No liability in case of design changes like: use of different oil, use of different starting equipment or motor protector. No warranty if operated relevant time outside of published operation limits.