

Model

Designation	MS18UVULTM	Sales code:	104M0823
-------------	-------------------	-------------	-----------------

Compressor design

Oil type	Polyolester	Refrigerant(s)	R290, R170, R1270
Oil viscosity	32cSt	Displacement	17,69cm ³ / 1,08cu.in
Oil quantity	473cm ³ / 16fl.oz	Compressors on pallet	80
Refr. charge - tech. limit	550g / 19,4oz		
Free gas volume comp.	1460cm ³ / 49,4fl.oz		
Weight	14,2kg / 31,3lbs		
Motor protection	2# internal		
Winding resist. ph. to ph.	3,92Ω (at 25°C)		
Max. winding temp.	125°C / 257°F		
Max. discharge temp.	130°C / 266°F		
Additional note	Good robustness against liquid intake. Compressor for laboratory and medical applications. Check special warranty terms with Secop Sales.		



General - Configurations and Applications with MS18UVULTM and Controller

	Conf. 1	Conf. 2	Conf. 3
Sales code single pack:	105N4932	105N4932	105N4932
Sales code industry pack:	105N4933	105N4933	105N4933
Power supply (nominal)	100-240V,50/60Hz	100-240V,50/60Hz	100-240V,50/60Hz
Approvals	UL,VDE,CCC	UL,VDE,CCC	UL,VDE
Refrigerant	R170	R290	R1270
Number of phases	1~AC	1~AC	1~AC
Application	ULT	L+MBP	LLBP
Starting torque	HST	HST	HST
Hot gas defrost	OK	OK	OK
Long interval pull down	OK	OK	OK
System cooling	Fan cooling 3m/s	Fan cooling 3m/s	Fan cooling 3m/s
Note	See operation limits for controller		

Controller functions

	Conf. 1	Conf. 2	Conf. 3
Protection	Mechanic	Mechanic	Mechanic
Max output power	1100W	1100W	1100W
No of relays	2	2	2
Hot gas defrost	yes	yes	yes
AEO speed setting	yes	yes	yes
Serial com, (Modbus)	SWI	SWI	SWI
DWI / Frequency input	yes	yes	yes
Reduced leakage current	yes	yes	yes
Note			

Model

Designation

MS18UVULTM

Sales code:

104M0823

Compressor dimensions

Housing	A Height	219,9mm / 8,66in
	B Height	214mm / 8,43in
	C Length shell	217mm / 8,54in
	D Length w. cover	257,6mm / 10,14in
	E Width	161,1mm / 6,34in

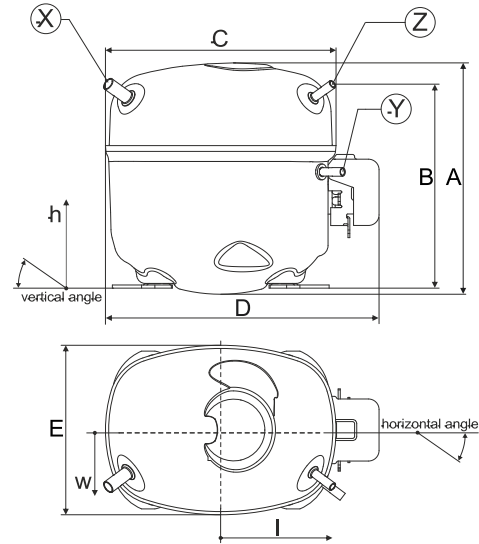

Connectors		Suction	Discharge	Process
		X	Y	Z
Diameter	[mm]	øi 9,54-9,72	øi 6,41-6,59	øi 6,41-6,59
(i:inside, o:outside)	[in]	øi 0,38-0,38	øi 0,25-0,26	øi 0,25-0,26
Material		copper	copper	copper
Horizontal angle	±2°	37°	37°	37°
Vertical angle	±2°	30°	0°	30°
Position l/h/w	[mm]	-106/193/57	114/110/81	106/94/72
	[in]	-4,2/7,6/2,2	4,5/4,3/3,2	4,2/3,7/2,8
Straight tube l.	[mm]	12	12	12
	[in]	0,5	0,5	0,5

Compressor fixation

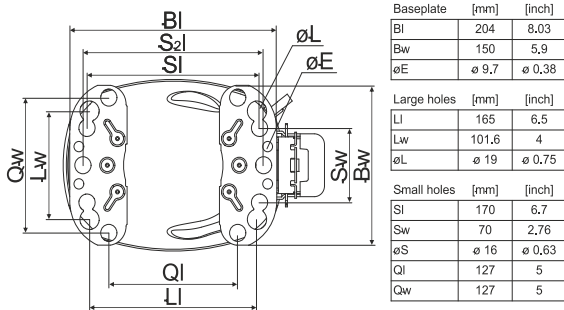

Bolt joint

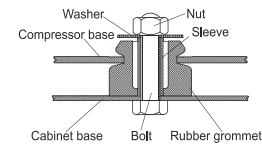

Snap-on

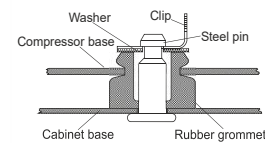

Mounting accessories

Bolt joint | M6 | ø16mm

Snap-on | ø7,3 | ø16mm

one comp. multi pack

118-1958 118-1961

118-1962

Application notes

Provision for PE Grounding is located at the PE Stamp on the compressor

Direct suction intake with telescope

QR Code and Hyperlink leads to the

[Operating Instructions.](#)



Model

Designation	MS18UVULTM	100-240V,50/60Hz	Conf. 1	Sales code:	104M0823
Controller	SLVE MP MV GFCI				105N4932

Sales code single pack:	105N4932 (1 units)
Sales code industry pack:	105N4933 (8 units)
Adaption to compressor:	detached
Protection class:	IP54
Weight:	1,4kg/3,08lbs
Voltage nom.:	100-240V,50/60Hz
Voltage range:	90–150/180–270V
Max. current:	4,2 A(230V)/8,4 A(115V)
LRA (Locked Rotor Amperage):	2,9A
Cable length:	915mm
Compressor speed range:	2200-4500rpm
Housing plastic:	UL94-5VA

Controller dimensions:

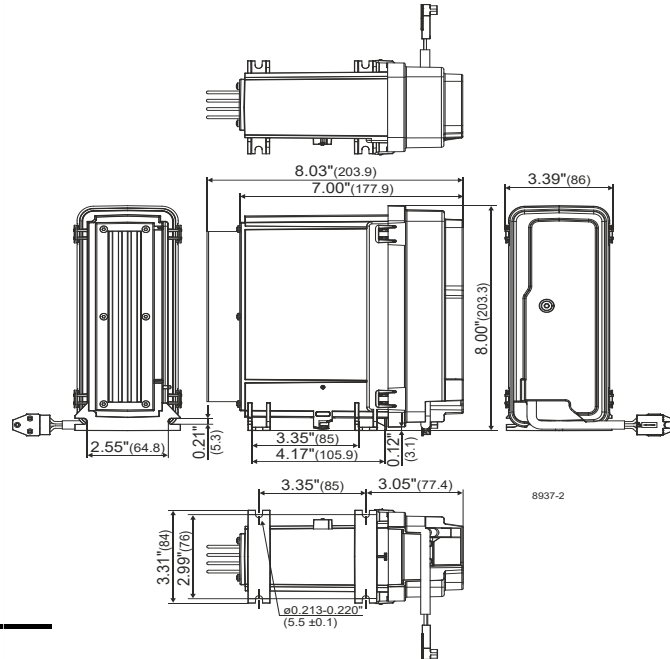

Operation Limits

Suctiongas temperature < +20°C (continuous operation)
 U:100-240V LBP; 208-240V MBP; 50/60Hz

System cooling

Ambient/ machineroom temperatures minimum /maximum

Ambient temperature range:	10 - 43°C / 50 - 110°F
Machine room temperature range compressor:	10 - 48°C / 50 - 119°F
Machine room temperature range controller:	10 - 50°C / 50 - 122°F

Compressor and Controller Cooling:

Fan cooling 3m/s
 Ensure proper airflow of 3 m/s at both compressor and electronic units.
 The airflow for the electronics must be directed to the heat sink.

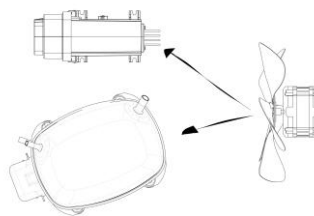

Operation pressure range

R170

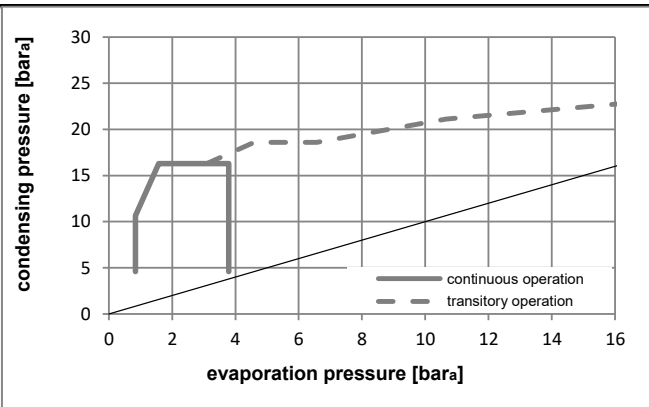
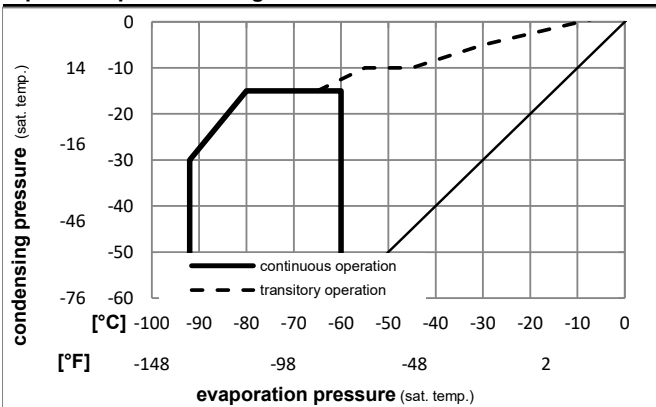

Model				
Designation	MS18UVULTM	100-240V,50/60Hz	Conf. 2	Sales code: 104M0823
Controller	SLVE MP MV GFCI			105N4932

Sales code single pack:	105N4932 (1 units)
Sales code industry pack:	105N4933 (8 units)
Adaption to compressor:	detached
Protection class:	IP54
Weight:	1,4kg/3,08lbs
Voltage nom.	100-240V,50/60Hz
Voltage range	90-150/180-270V
Max. current:	4,2 A(230V)/8,4 A(115V)
LRA (Locked Rotor Amperage)	2,9A
Cable length:	915mm
Compressor speed range:	2200-4500rpm
Housing plastic:	UL94-5VA

Controller dimensions:

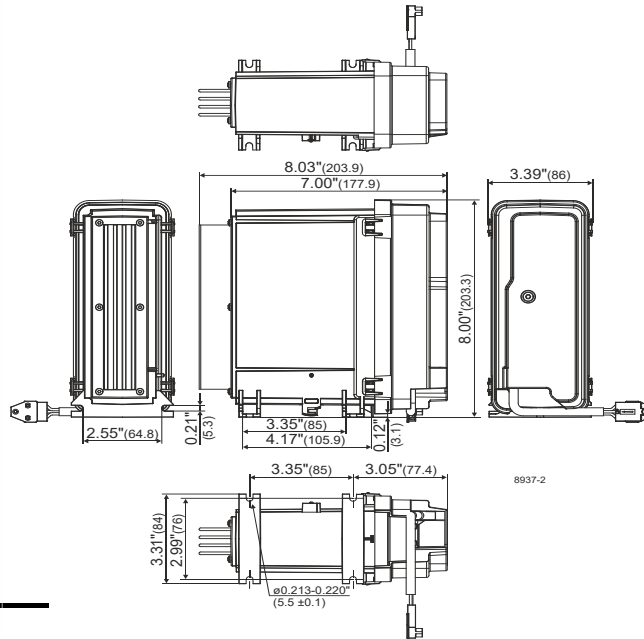

Operation Limits

Suctiongas temperature < +20°C (continous operation)
 U:100-240V LBP; 208-240V MBP; 50/60Hz

System cooling

Ambient/ machineroom temperatures minimum /maximum	
Ambient temperature range:	10 - 43°C / 50 - 110°F
Machine room temperature range compressor:	10 - 48°C / 50 - 119°F
Machine room temperature range controller:	10 - 50°C / 50 - 122°F
Compressor and Controller Cooling:	Fan cooling 3m/s

Ensure proper airflow of 3 m/s at both compressor and electronic units.
 The airflow for the electronics must be directed to the heat sink.

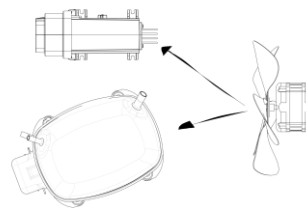

Operation pressure range

R290

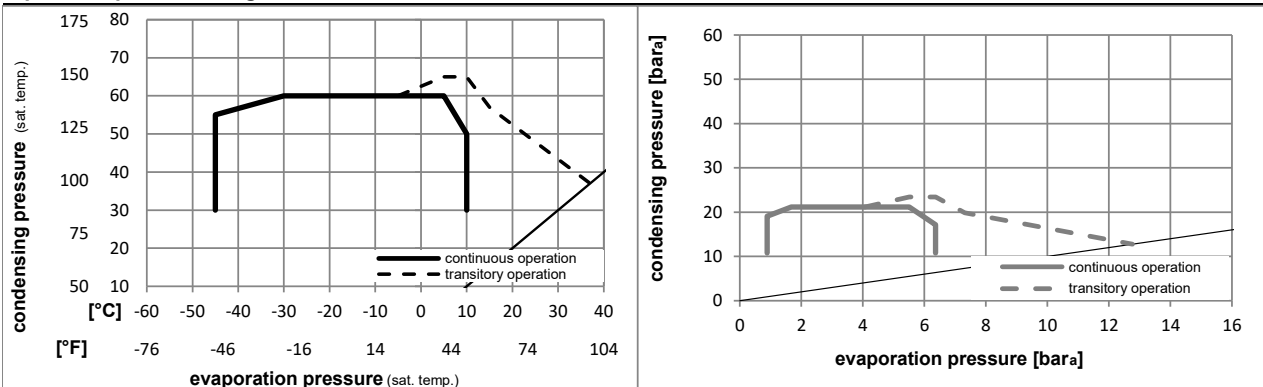

Model

Designation **MS18UVULTM 100-240V,50/60Hz Conf. 3** Sales code: **104M0823**

Controller **SLVE MP MV GFCI** **105N4932**

Sales code single pack: 105N4932 (1 units)

Controller dimensions:

Sales code industry pack: 105N4933 (8 units)

Adaption to compressor: detached

Protection class: IP54

Weight: 1,4kg/3,08lbs

Voltage nom. 100-240V,50/60Hz

Voltage range 90-150/180-270V

Max. current: 4,2 A(230V)/8,4 A(115V)

LRA (Locked Rotor Amperage) 2,9A

Cable length: 915mm

Compressor speed range: 2200-4500rpm

Housing plastic: UL94-5VA

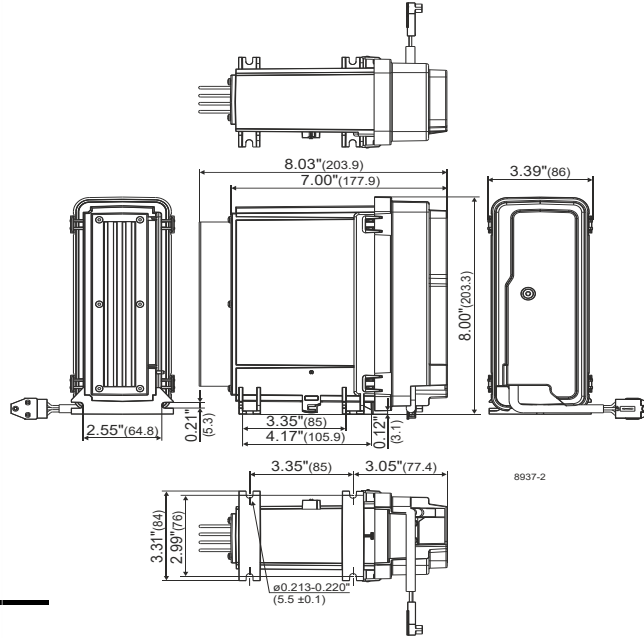

Operation Limits

Suctiongas temperature < +20°C (continous operation)

U:100-240V LBP; 208-240V MBP; 50/60Hz

System cooling

Ambient/ machineroom temperatures minimum /maximum

Ambient temperature range: 10 - 43°C / 50 - 110°F

Machine room temperature range compressor: 10 - 48°C / 50 - 119°F

Machine room temperature range controller: 10 - 50°C / 50 - 122°F

Compressor and Controller Cooling: Fan cooling 3m/s

Ensure proper airflow of 3 m/s at both compressor and electronic units.

The airflow for the electronics must be directed to the heat sink.

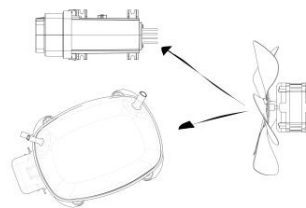

Operation pressure range

R1270

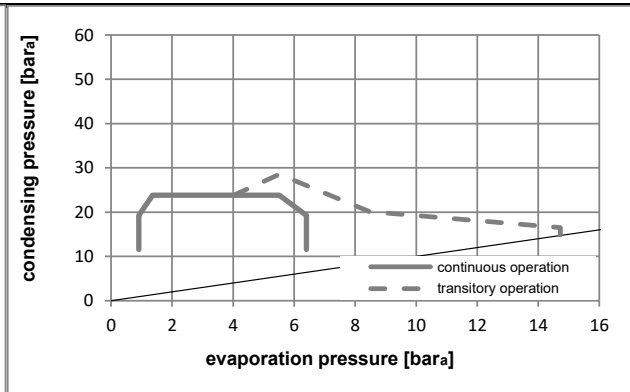
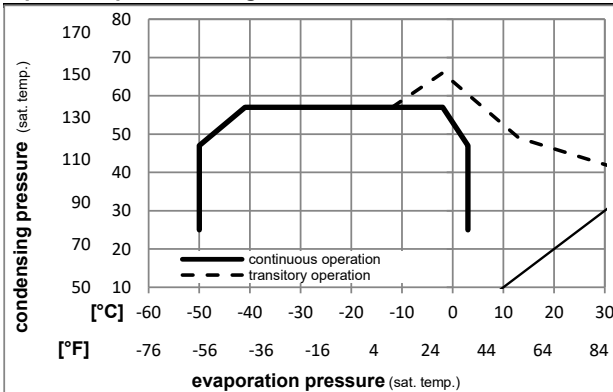

Model

Designation **MS18UVULTM 100-240V,50/60Hz Conf. 1,2,3** Sales code: **104M0823**

Controller **SLVE MP MV GFCI** **105N4932**

Controller connections

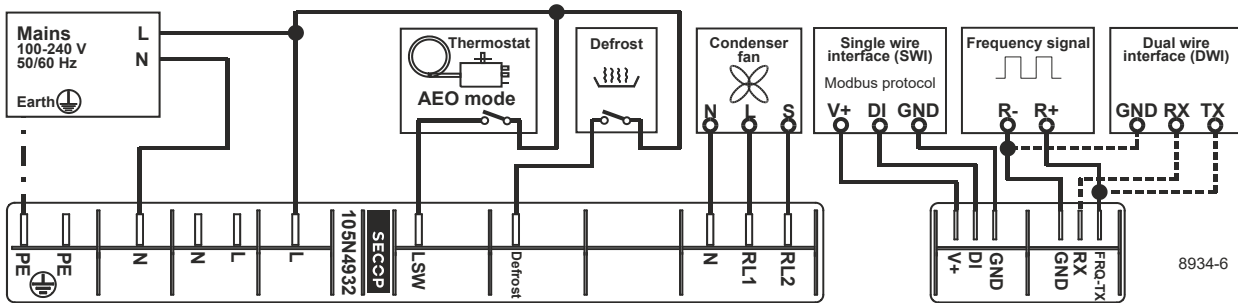
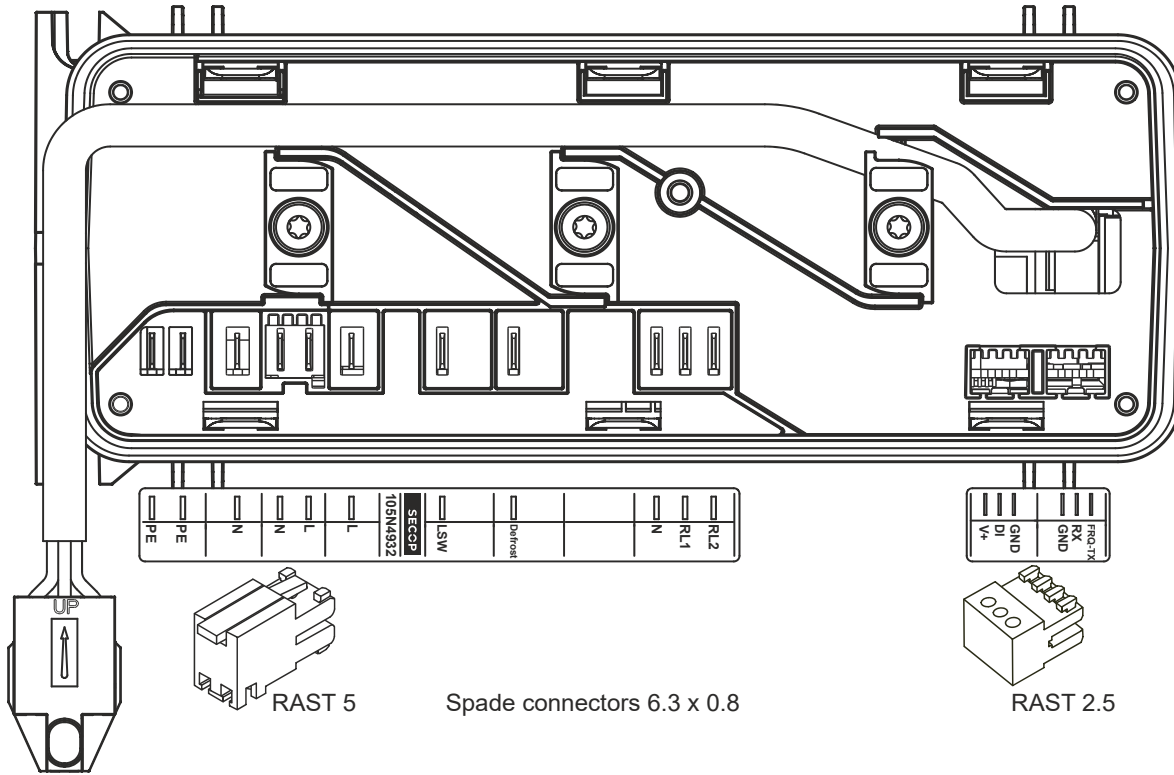

Accessories (Compressor + Controller) - check operation manual for details

103N2008 plastic cover 1 pcs

Model

Designation **MS18UVULTM 100-240V,50/60Hz Conf. 1** Sales code: **104M0823**

Controller **SLVE MP MV GFCI** **105N4932**

Optimization + standard conditions

R170, 220V, 50Hz, Rpm_N 4500, Fan cooling 3m/s

	Evaporating pressure (saturation temperature)		Condensing pressure (saturation temperature)				Return gas temp.			Liquid temp.			Cooling capacity			COP			EER			Power consumption			Ref. mass flow \dot{m} [kg/h]
	pe	pc	RGT	Tliq	[W]	[Btu/h]	[kcal/h]	[W/W]	[Btu/Wh]	[kcal/Wh]	P1	I													
	[°C]	[°C]	[°C]	[°C]							[W]	[A]													
ULT 1	-85	-35	10	-15	584,6	1996	503,1	1,38	4,71	1,19	423,7	2,10	4,76												
	[°F]	[°F]																							
ULT 2	-85	-40	10	-20	627,0	2141	539,6	1,56	5,33	1,34	401,9	2,00	4,93												
	[°F]	[°F]																							
ULT 3	-85	-45	10	-25	667,6	2280	574,6	1,77	6,06	1,53	376,3	1,87	5,08												
	[°F]	[°F]																							
ULT 4	-95	-35	10	-30	304,6	1040	262,2	1,03	3,50	0,88	297,1	1,48	2,25												
	[°F]	[°F]																							
ULT 5	-95	-40	10	-35	339,8	1160	292,4	1,18	4,04	1,02	287,4	1,43	2,43												
	[°F]	[°F]																							
ULT 6	-95	-45	10	-40	373,9	1277	321,7	1,36	4,66	1,17	274,0	1,37	2,60												
	[°F]	[°F]																							

Standard conditions with different RPM

R170, 220V, 50Hz, Fan cooling 3m/s

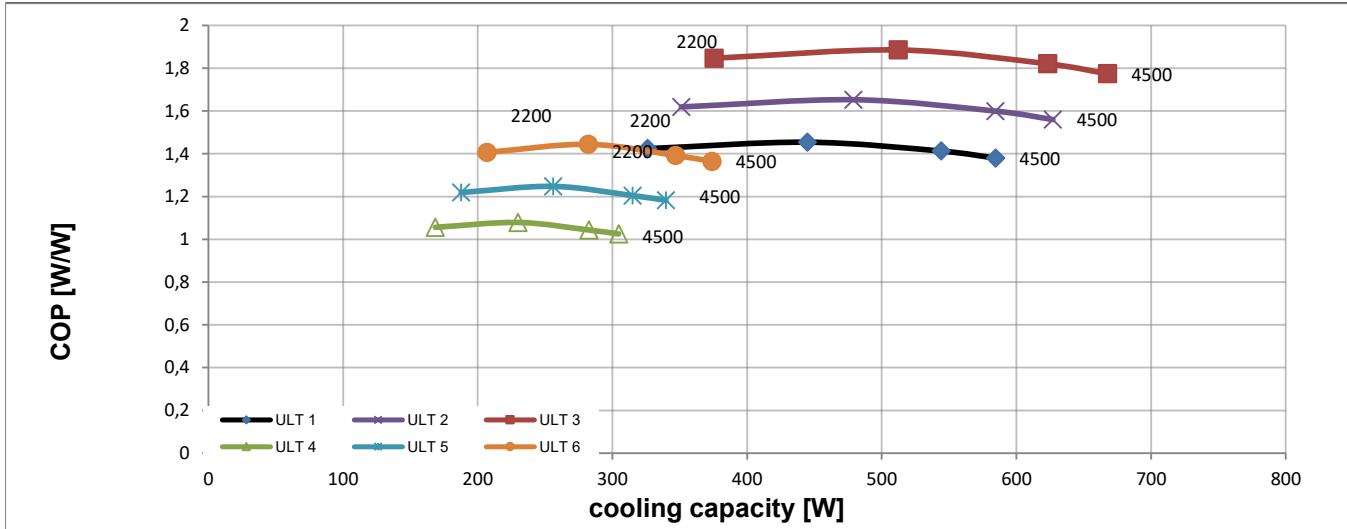

Test conditions:	pe [°C]	pc [°C]	Tliq [°C]	Tsuc [°C]
ULT 1	-85	-35	-15	10
ULT 2	-85	-40	-20	10
ULT 3	-85	-45	-25	10
ULT 4	-95	-35	-30	10
ULT 5	-95	-40	-35	10
ULT 6	-95	-45	-40	10

Model

Designation **MS18UVULTM 100-240V,50/60Hz Conf. 2** Sales code: **104M0823**

Controller **SLVE MP MV GFCI** **105N4932**

Optimization + standard conditions

R290, 220V, 50Hz, Rpm_N 4500, Fan cooling 3m/s

	Evaporating pressure (saturation temperature)				Condensing pressure (saturation temperature)			COP	EER	Power consumption			ASHRAE LBP	
	pe	pc	RGT	Tliq	[W]	[Btu/h]	[kcal/h]			P1	I	ṁ		
	[°C]	[°F]	[°C]	[°F]	[W]	[Btu/h]	[kcal/h]	[W/W]	[Btu/Wh]	[kcal/Wh]	[W]	[A]	[kg/h]	
	-23	54	32	32	1196,4	4086	1029,6	1,71	5,85	1,47	698,9	3,43	12,12	ASHRAE LBP
	-10	130	90	90										
	-25	55	32	55	891,7	3045	767,4	1,33	4,54	1,14	671,4	3,29	11,10	CECOMAF LBP
	-13	131	90	131										
	-35	40	20	40	654,6	2236	563,4	1,35	4,62	1,17	483,4	2,39	7,48	EN12900 LBP
	-31	104	68	104										
	-7	54	35	46	2172,8	7420	1869,9	2,22	7,57	1,91	979,8	4,76	24,79	ASHRAE MBP
	20	130	95	115										
	-10	55	32	55	1727,2	5899	1486,4	1,85	6,33	1,59	932,4	4,53	21,85	CECOMAF MBP
	14	131	90	131										
	-10	45	20	45	1890,2	6455	1626,7	2,26	7,73	1,95	835,4	4,07	23,21	EN12900 MBP
	14	113	68	113										

Standard conditions with different RPM

R290, 220V, 50Hz, Fan cooling 3m/s

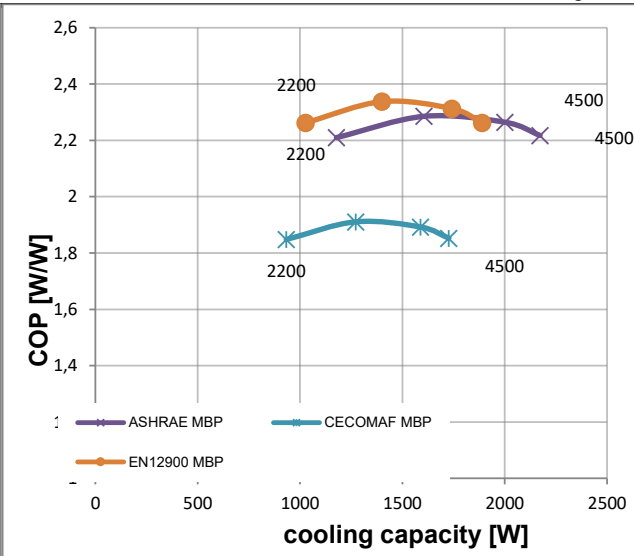
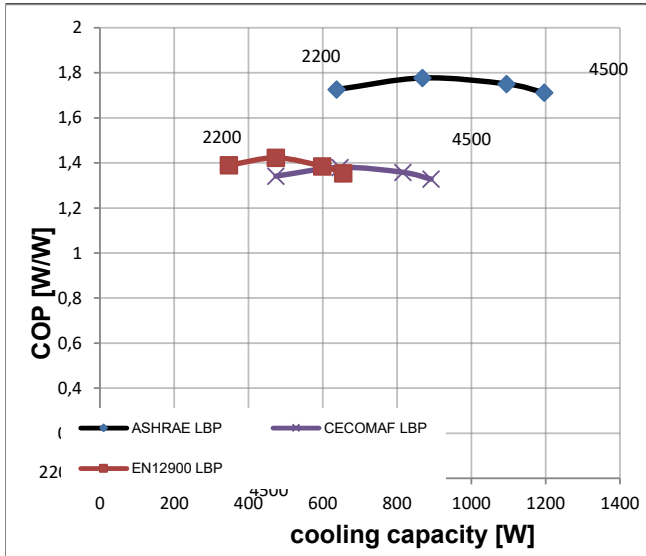

Test conditions:

	pe [°C]	pc [°C]	Tliq [°C]	Tsuc [°C]
ASHRAE LBP	-23	54,44	32,22	32,22
CECOMAF LBP	-25	55	55	32
EN12900 LBP	-35	40	40	20

	pe [°C]	pc [°C]	Tliq [°C]	Tsuc [°C]
ASHRAE MBP	-6,66	54,44	46,11	35,00
CECOMAF MBP	-10,00	55,00	55,00	32,00
EN12900 MBP	-10,00	45,00	45,00	20,00

Model

Designation **MS18UVULTM 100-240V,50/60Hz Conf. 3** Sales code: **104M0823**

Controller **SLVE MP MV GFCI** **105N4932**

Optimization + standard conditions

R1270, 220V, 50Hz, Rpm_N 4500, Fan cooling 3m/s

	Evaporating pressure (saturation temperature)				Condensing pressure (saturation temperature)			COP	EER	Power consumption	Current consumption		Ref. mass flow	
	pe	pc	RGT	Tliq	[W]	[Btu/h]	[kcal/h]				P1	I		
	[°C]	[°C]	[°C]	[°C]	[W]	[Btu/h]	[kcal/h]	[W/W]	[Btu/Wh]	[kcal/Wh]	[W]	[A]	[kg/h]	
ASHRAE LBP	-23	54	32	32	1384,0	4726	1191,1	1,66	5,68	1,43	832,3	4,06	13,98	
CECOMAF LBP	-25	55	32	55	1037,6	3544	893,0	1,30	4,43	1,12	799,9	3,90	12,85	
EN12900 LBP	-35	40	20	40	771,2	2634	663,7	1,36	4,63	1,17	568,3	2,80	8,72	
opt LBP 1	-40	35	20	35	631,0	2155	543,0	1,31	4,46	1,12	482,9	2,39	6,82	
opt LBP 2	-40	40	20	40	577,7	1973	497,1	1,18	4,03	1,01	489,9	2,42	6,52	
opt LBP 3	-40	45	20	45	524,6	1792	451,5	1,06	3,62	0,91	495,2	2,45	6,20	

Standard conditions with different RPM

R1270, 220V, 50Hz, Fan cooling 3m/s

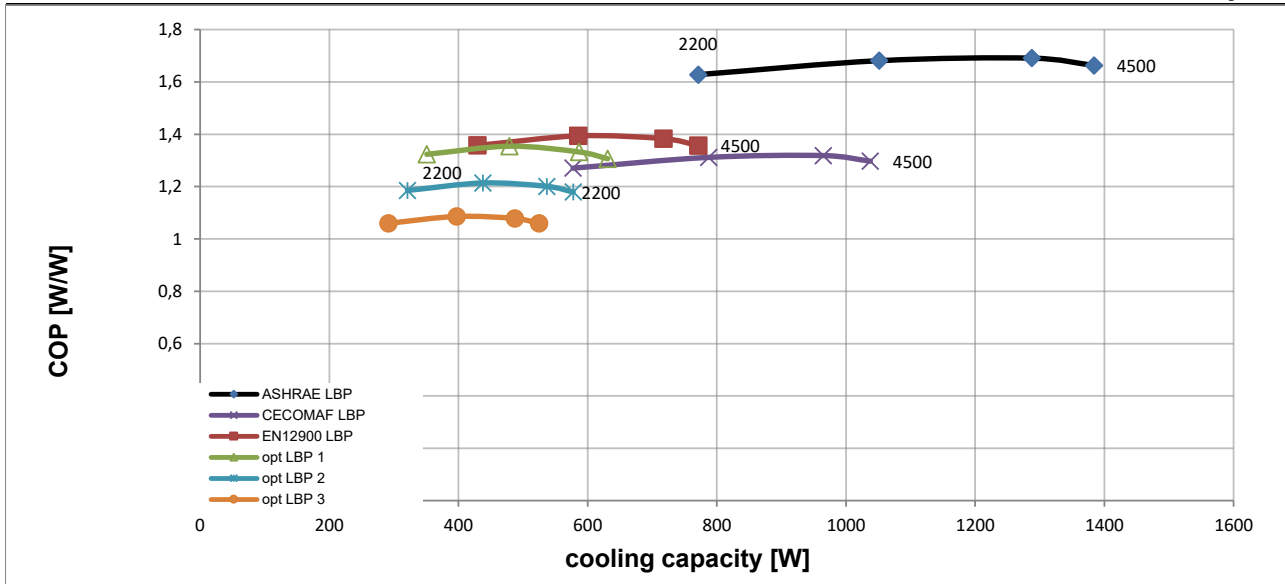

Test conditions:	pe [°C]	pc [°C]	Tliq [°C]	Tsuc [°C]
ASHRAE LBP	-23	54	32	32
CECOMAF LBP	-25	55	55	32
EN12900 LBP	-35	40	40	20
opt LBP 1	-40	35	35	20
opt LBP 2	-40	40	40	20
opt LBP 3	-40	45	45	20