

Model

Designation	NF11FX.2	115-127V/60Hz 1~	Sales code:	105G5916
-------------	-----------------	-------------------------	-------------	-----------------

Compressor design

Oil type	Polyolester	Refrigerant(s)	R134a, R513A
Oil viscosity	32cST	Displacement	11,25cm ³ / 0,69cu.in
Oil quantity	294cm ³ / 10fl.oz	Compressors on pallet	80
Refr. charge - tech. limit	400g / 14,1oz		
Free gas volume comp.	2360cm ³ / 79,8fl.oz		
Weight	10kg / 22lbs		
Motor protection	external		
Winding resistance main	1Ω (at 25°C)		
Winding resistance aux	2,9Ω (at 25°C)		
Max. winding temp.	125°C / 257°F		
Max. discharge temp.	130°C / 266°F		



General - Configurations with NF11FX.2

	Conf. 1	Conf. 2
Motorconfiguration	CSIR	CSIR
Power supply (nominal)	115V/60Hz	115V/60Hz
Number of phases	1	1
Voltage range	95-135V	95-135V
Approvals	UL, EAC	UL
Starting torque	HST	HST
Note	- / -	

Applications with NF11FX.2

	Conf. 1	Conf. 2
Refrigerant	R134a	R513A
Application	MBP	MBP
System cooling	fan 3m/s	fan 3m/s
Hot gas defrost	OK	OK
Long interval pull down	OK	OK

Electrical data - Configurations with NF11FX.2

	Conf. 1	Conf. 2
Starting device type	relay	relay
Run capacitor	- / -	- / -
Start capacitor	410μF	410μF
LRA (locked rotor amps / 4s)	40A	40A
RLA (rated load amps / 1s)	7A	7A
Cut in current	40A	40A
IP class	21	21

Model

Designation	NF11FX.2	115-127V/60Hz 1~	Sales code:	105G5916
-------------	-----------------	-------------------------	-------------	-----------------

Compressor dimensions

Housing	A Height	203mm / 7,99in
	B Height	197mm / 7,76in
	C Length shell	205mm / 8,07in
	D Length w. cover	254mm / 10in
	E Width	166mm / 6,54in

Connectors		Suction	Discharge	Process
		X	Y	Z
Diameter	[mm]	øi 8,11-8,29	øi 6,41-6,59	øi 6,41-6,59
(i:inside, o:outside)	[in]	øi 0,32-0,33	øi 0,25-0,26	øi 0,25-0,26
Material		copper	copper	copper
Horizontal angle	±2°	0°	0°	0°
Vertical angle	±2°	15°	35°	155°
Position l/h/w	[mm]	126/76/78	133/103/54	-107/94/72
	[in]	4,9/3/3,1	5,2/4/2,1	-4,2/3,7/2,8
Straight tube l.	[mm]	12	12	12
	[in]	0,5	0,5	0,5

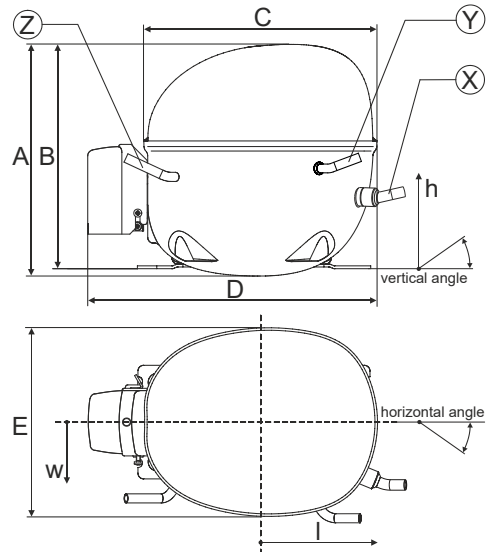

Compressor fixation

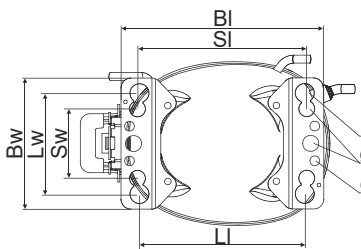

Baseplate	[mm]	[inch]
BI	204	8.03
Bw	132	5.2
øE	ø 9.7	ø 0.38
Large holes	[mm]	[inch]
LI	165	6.5
Lw	101.6	4
øL	ø 19	ø 0.75
Small holes	[mm]	[inch]
SI	170	6.7
Sw	70	2.76
øS	ø 16	ø 0.63

Bolt joint

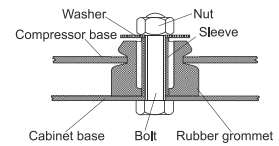

Snap-on

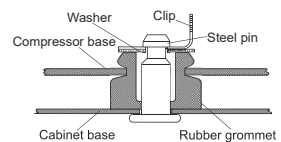

Mounting accessories	one comp.	multi pack
Bolt joint M6 ø16mm	118-1917	118-1918
Bolt joint ø1/4" ø16mm	118-1946	
Bolt joint ø1/4" ø19mm	118-1949	
Snap-on ø7,3 ø16mm	118-1947	118-1919

Application notes

LRA value on compressor label and datasheet may differ due to different test conditions for UL approval.

Model

Designation	NF11FX.2	115V/60Hz	Conf. 1	Sales code:	105G5916
-------------	-----------------	------------------	----------------	-------------	-----------------

Configuration

Motorconfiguration	CSIR
Power supply (nominal)	115V/60Hz 1~
Refrigerant	R134a
Application	MBP
Voltage range	95-135V
Starting torque	HST
Approvals	UL
	EAC

Electrical accessories / wiring diagram

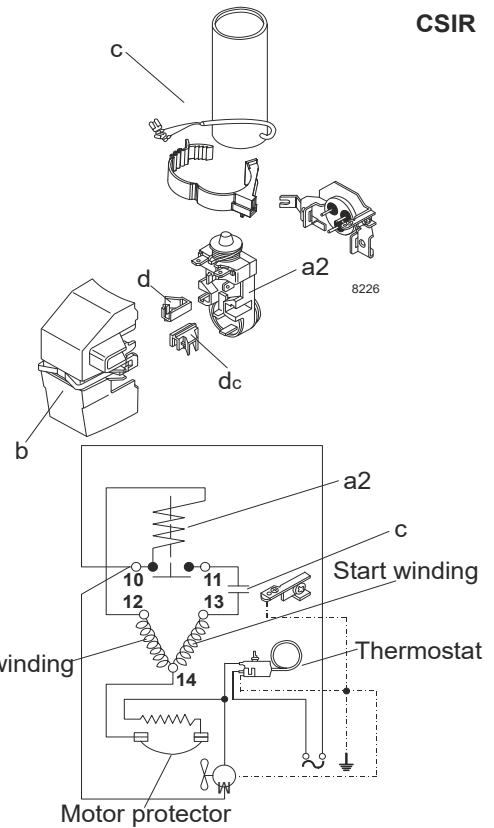

Ambient temperatures / system cooling

Ambient temperature min.:	10°C / 50°F
Ambient temperature max.:	43°C / 110°F

System cooling (n/a: outside limits)			
T ambient	LBP	MBP	HBP
32°C / 90°F	n/a	fan 3m/s	n/a
38°C / 100°F	n/a	fan 3m/s	n/a
43°C / 110°F	n/a	fan 3m/s	n/a

Operation pressure range

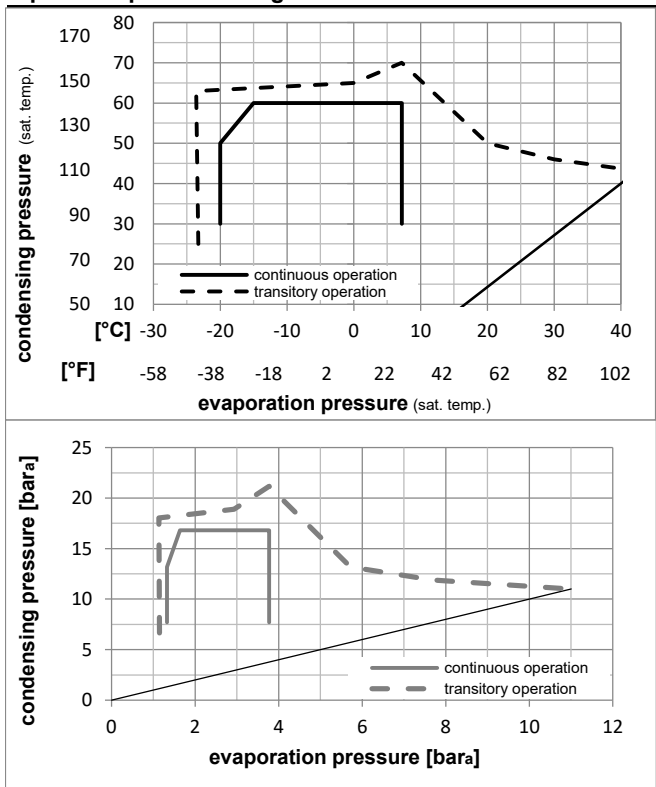

Components

a2	assy. Relay (TI MRT16ADK-6)	117U4151
c	start capacitor (410µF)	117U5028
b	plastic cover	117U1021
d/dc	cord relief	117U0349
d/dc	cord relief	117U0349

Model

Designation **NF11FX.2 115V/60Hz** Conf. 1 Sales code: **105G5916**

Optimization + standard conditions

115V/60Hz, CSIR, fan 3m/s, UL, EAC

Evaporating pressure (saturation temperature)					Condensing pressure (saturation temperature)						Power consumption				ASHRAE LBP
Return gas temp.					Liquid temp.						Current consumption			Ref. mass flow m	
Cooling capacity					COP		EER		P1	I	m				
pe	pc	RGT	Tliq	[W]	[Btu/h]	[kcal/h]	[W/W]	[Btu/Wh]	[kcal/Wh]	[W]		[A]	[kg/h]		
[°C]	-23,3	54,4	32,2	32,2	381,5	1303	328,3	1,16	3,95	0,99	330,2	5,21	7,41	ASHRAE LBP	
[°F]	-10	130	90	90											
[°C]	-25	55	32	55	277,9	949	239,2	0,89	3,02	0,76	313,9	5,14	6,65	cecomaf LBP	
[°F]	-13	131	89,6	131											
[°C]	-35	40	20	40	187,1	639	161,0	0,78	2,67	0,67	239,3	4,88	4,10	EN12900 LBP	
[°F]	-31	104	68	104											
[°C]	-6,66	54,4	35	46,1	795,8	2718	684,9	1,65	5,63	1,42	483,2	6,02	17,36	ASHRAE MBP	
[°F]	20	130	95	115											
[°C]	-10	55	32	55	617,9	2110	531,8	1,36	4,66	1,17	453,3	5,84	14,94	cecomaf MBP	
[°F]	14	131	89,6	131											
[°C]	-10	45	20	45	695,4	2375	598,5	1,62	5,52	1,39	430,3	5,70	16,28	EN12900 MBP	
[°F]	14	113	68	113											

Performance tables

115V/60Hz, CSIR, fan 3m/s, UL, EAC

	pe	Cooling capacity			COP		EER		P1	I	m
	[°C]	[°F]	[W]	[Btu/h]	[kcal/h]	[W/W]	[Btu/Wh]	[kcal/Wh]	[W]	[A]	[kg/h]
[°C / °F]	-20	-4	448,6	1532	386,1	1,26	4,32	1,09	355,1	5,28	9,75
cond. pressure	-15	5	574,9	1963	494,8	1,46	5,00	1,26	392,5	5,48	12,53
pc= 45/113	-9,4	15	739,1	2524	636,1	1,70	5,81	1,46	434,6	5,72	16,18
return gas temp.	-6,7	20	831,4	2839	715,5	1,82	6,22	1,57	456,3	5,86	18,25
RGT= 32/90	-3,9	25	930,8	3179	801,1	1,94	6,64	1,67	478,8	6,00	20,49
liquid temp	0	32	1082,9	3698	931,9	2,11	7,22	1,82	512,1	6,22	23,95
Tliq= 45/113	7,2	45	1407,6	4807	1211,4	2,42	8,27	2,09	580,9	6,66	31,44
[°C / °F]	-20	-4	372,6	1273	320,7	1,03	3,52	0,89	361,3	5,35	8,94
cond. pressure	-15	5	485,3	1658	417,7	1,19	4,07	1,03	407,3	5,58	11,68
pc= 55/131	-9,4	15	634,0	2165	545,6	1,38	4,72	1,19	458,5	5,87	15,34
return gas temp	-6,7	20	718,3	2453	618,2	1,48	5,06	1,28	484,6	6,03	17,43
RGT= 32/90	-3,9	25	809,8	2765	696,9	1,58	5,41	1,36	511,3	6,20	19,71
liquid temp	0	32	950,4	3246	817,9	1,73	5,90	1,49	550,3	6,44	23,25
Tliq= 55/131	7,2	45	1253,3	4280	1078,6	1,99	6,80	1,71	629,1	6,94	31,00

Model

Designation	NF11FX.2	115V/60Hz	Conf. 2	Sales code:	105G5916
-------------	-----------------	------------------	----------------	-------------	-----------------

Configuration

Motorconfiguration	CSIR
Power supply (nominal)	115V/60Hz 1~
Refrigerant	R513A
Application	MBP
Voltage range	95-135V
Starting torque	HST
Approvals	UL

Electrical accessories / wiring diagram

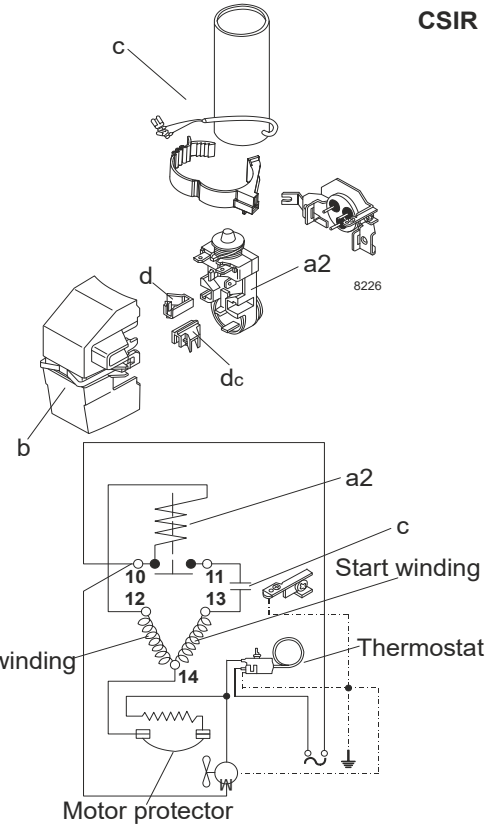

Ambient temperatures / system cooling

Ambient temperature min.:	10°C / 50°F
Ambient temperature max.:	43°C / 110°F

System cooling (n/a: outside limits)			
T ambient	LBP	MBP	HBP
32°C / 90°F	n/a	fan 3m/s	n/a
38°C / 100°F	n/a	fan 3m/s	n/a
43°C / 110°F	n/a	fan 3m/s	n/a

Operation pressure range

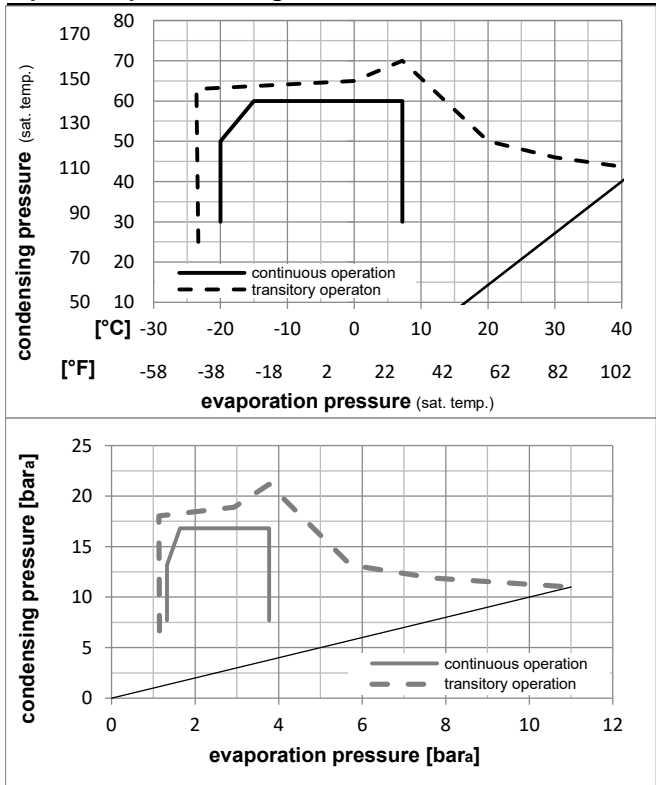

Components

a2	assy. Relay (TI MRT16ADK-6)	117U4151
c	start capacitor (410µF)	117U5028
b	plastic cover	117U1021
d/dc	cord relief	117U0349
d/dc	cord relief	117U0349

Model

Designation **NF11FX.2 115V/60Hz** Conf. **2** Sales code: **105G5916**

Optimization + standard conditions

115V/60Hz, CSIR, fan 3m/s, UL

Evaporating pressure (saturation temperature)														
Condensing pressure (saturation temperature)														
Return gas temp.														
Liquid temp.														
Cooling capacity														
COP														
EER														
Power consumption														
Current consumption														
Ref. mass flow														
	pe	pc	RGT	Tliq	[W]	[Btu/h]	[kcal/h]	[W/W]	[Btu/Wh]	[kcal/Wh]	P1	I	m	
[°C]	[°C]	[°C]	[°C]	[°C]	[W]	[Btu/h]	[kcal/h]	[W/W]	[Btu/Wh]	[kcal/Wh]	[W]	[A]	[kg/h]	
[°C]	-23,3	54,4	32,2	32,2	424,6	1450	365,4	1,17	3,99	1,01	363,3	5,35	9,14	ASHRAE LBP
[°F]	-10	130	90	90										
[°C]	-25	55	32	55	301,5	1030	259,5	0,87	2,97	0,75	347,2	5,26	8,26	cecomaf LBP
[°F]	-13	131	89,6	131										
[°C]	-35	40	20	40	211,9	724	182,3	0,79	2,70	0,68	268,2	4,80	5,24	EN12900 LBP
[°F]	-31	104	68	104										
[°C]	-6,66	54,4	35	46,1	836,2	2856	719,6	1,62	5,55	1,40	514,8	6,23	20,48	ASHRAE MBP
[°F]	20	130	95	115										
[°C]	-10	55	32	55	642,0	2193	552,5	1,32	4,52	1,14	485,5	6,06	17,75	cecomaf MBP
[°F]	14	131	89,6	131										
[°C]	-10	45	20	45	727,5	2484	626,1	1,58	5,41	1,36	459,5	5,91	19,28	EN12900 MBP
[°F]	14	113	68	113										

Performance tables

115V/60Hz, CSIR, fan 3m/s, UL

	pe	Cooling capacity			COP	EER	P1	I	m			
		[°C]	[°F]	[W]						[Btu/h]	[kcal/h]	[W/W]
[°C / °F]	-20	-4		483,4	1651	416,0	1,25	4,29	1,08	385,3	5,48	11,81
cond. pressure	-15	5		612,3	2091	527,0	1,45	4,95	1,25	422,2	5,69	15,00
pc= 45/113	-9,4	15		778,5	2659	670,0	1,68	5,73	1,44	463,7	5,93	19,15
return gas temp.	-6,7	20		871,4	2976	749,9	1,80	6,13	1,55	485,1	6,06	21,48
RGT= 32/90	-3,9	25		971,2	3317	835,8	1,91	6,54	1,65	507,3	6,19	24,00
liquid temp	0	32		1123,1	3836	966,6	2,08	7,10	1,79	540,2	6,38	27,86
Tliq= 45/113	7,2	45		1445,7	4937	1244,2	2,38	8,11	2,04	608,6	6,77	36,16
[°C / °F]	-20	-4		397,2	1357	341,8	1,01	3,44	0,87	394,4	5,53	10,91
cond. pressure	-15	5		510,1	1742	439,0	1,16	3,96	1,00	440,0	5,80	14,05
pc= 55/131	-9,4	15		657,9	2247	566,2	1,34	4,58	1,15	490,6	6,09	18,20
return gas temp	-6,7	20		741,4	2532	638,0	1,44	4,90	1,24	516,4	6,24	20,56
RGT= 32/90	-3,9	25		831,6	2840	715,6	1,53	5,23	1,32	542,9	6,39	23,12
liquid temp	0	32		969,7	3312	834,5	1,67	5,70	1,44	581,4	6,62	27,08
Tliq= 55/131	7,2	45		1265,7	4323	1089,3	1,92	6,55	1,65	659,7	7,07	35,68