

Model

Designation	NL10FT	220-240V/50Hz 1~	Sales code:	105G6829
-------------	---------------	-------------------------	-------------	-----------------

Compressor design

Oil type	Polyolester	Refrigerant(s)	R134a
Oil viscosity	32cST	Displacement	10,09cm ³ / 0,62cu.in
Oil quantity	300cm ³ / 10,1fl.oz	Compressors on pallet	80
Refr. charge - tech. limit	400g / 14,1oz		
Free gas volume comp.	2360cm ³ / 79,8fl.oz		
Weight	10,5kg / 23,1lbs		
Motor protection	1# internal		
Winding resistance main	8,7Ω (at 25°C)		
Winding resistance aux	13,8Ω (at 25°C)		
Max. winding temp.	125°C / 257°F		
Max. discharge temp.	130°C / 266°F		



General - Configurations with NL10FT

	Conf. 1	Conf. 2
Motorconfiguration	RSIR	CSIR
Power supply (nominal)	220-240V/50Hz	220-240V/50Hz
Number of phases	1	1
Voltage range	187-254V	187-254V
Approvals	VDE, CCC, EAC	VDE, CCC, EAC
Starting torque	LST	HST
Note	- / -	

Applications with NL10FT

	Conf. 1	Conf. 2
Refrigerant	R134a	R134a
Application	LBP	LBP
System cooling	static	static
Hot gas defrost	- / -	- / -
Long interval pull down	- / -	- / -

Electrical data - Configurations with NL10FT

	Conf. 1	Conf. 2
Starting device type	PTC	relay
Run capacitor	- / -	- / -
Start capacitor	- / -	80μF
LRA (locked rotor amps / 4s)	9,2A	10,4A
RLA (rated load amps / 1s)	1,8A	1,8A
Cut in current	13,6A	10,4A

Model

Designation	NL10FT	220-240V/50Hz 1~	Sales code:	105G6829
-------------	---------------	-------------------------	-------------	-----------------

Compressor dimensions

Housing	A Height	203mm / 7,99in
	B Height	197mm / 7,76in
	C Length shell	205mm / 8,07in
	D Length w. cover	254mm / 10in
	E Width	166mm / 6,54in

Connectors		Suction	Discharge	Process
		X	Y	Z
Diameter	[mm]	øi 8,11-8,29	øi 6,11-6,29	øi 6,11-6,29
(i:inside, o:outside)	[in]	øi 0,32-0,33	øi 0,24-0,25	øi 0,24-0,25
Material		copper	copper	copper
Horizontal angle	±2°	0°	0°	0°
Vertical angle	±2°	15°	35°	155°
Position l/h/w	[mm]	126/76/78	133/103/54	-107/94/72
	[in]	4,9/3/3,1	5,2/4/2,1	-4,2/3,7/2,8
Straight tube l.	[mm]	12	12	12
	[in]	0,5	0,5	0,5

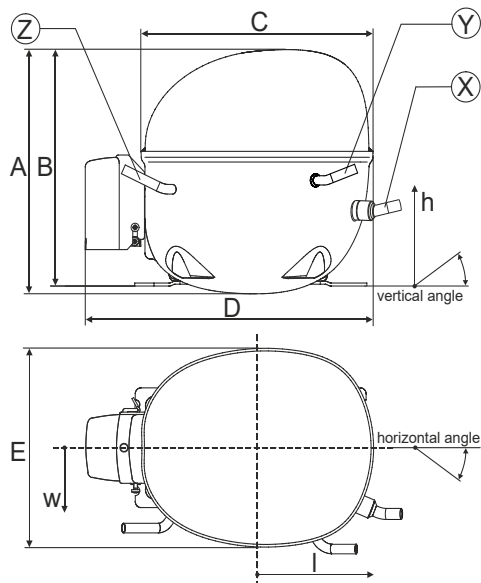

Compressor fixation

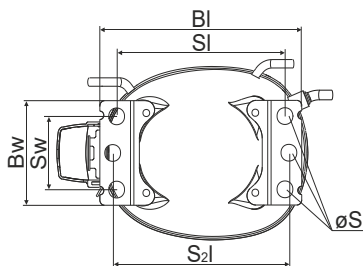

Baseplate	[mm]	[inch]
BI	204	8.03
BW	100	3.94

Small holes	[mm]	[inch]
SI	170	6.7
SW	70	2.76
S2l	178	7
øS	ø 16	ø 0.63

Bolt joint

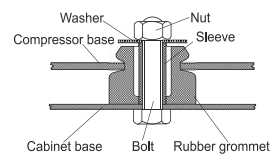

Snap-on

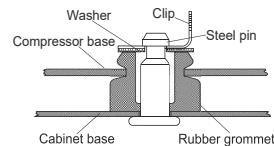

Mounting accessories

	one comp.	multi pack
Bolt joint M6 ø16mm	118-1917	118-1918
Bolt joint ø1/4" ø16mm	118-1946	
Bolt joint ø1/4" ø19mm	118-1949	
Snap-on ø7,3 ø16mm	118-1947	118-1919

Model

Designation	NL10FT	220-240V/50Hz	Conf. 1	Sales code:	105G6829
-------------	---------------	----------------------	----------------	-------------	-----------------

Configuration

Motorconfiguration	RSIR
Power supply (nominal)	220-240V/50Hz 1~
Refrigerant	R134a
Application	LBP
Voltage range	187-254V
Starting torque	LST
Approvals	VDE CCC EAC

Electrical accessories / wiring diagram

RSIR

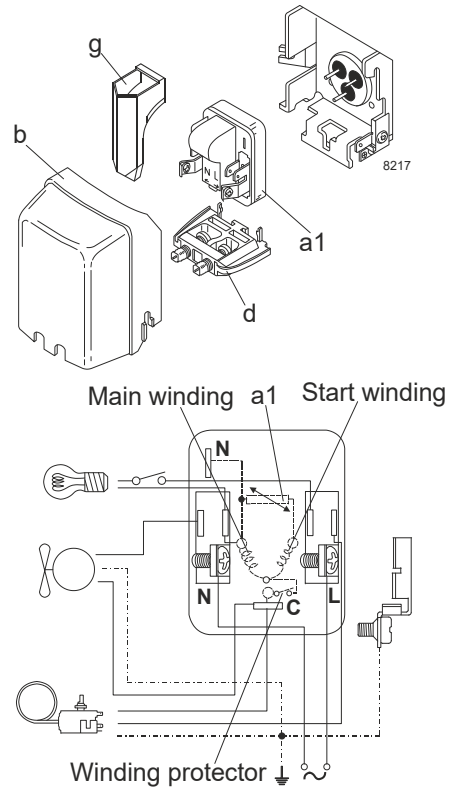

Ambient temperatures / system cooling

Ambient temperature min.:	10°C / 50°F
Ambient temperature max.:	43°C / 110°F

System cooling (n/a: outside limits)			
T ambient	LBP	MBP	HBP
32°C / 90°F	static	n/a	n/a
38°C / 100°F	fan 1,5m/s	n/a	n/a
43°C / 110°F	fan 3m/s	n/a	n/a

Operation pressure range

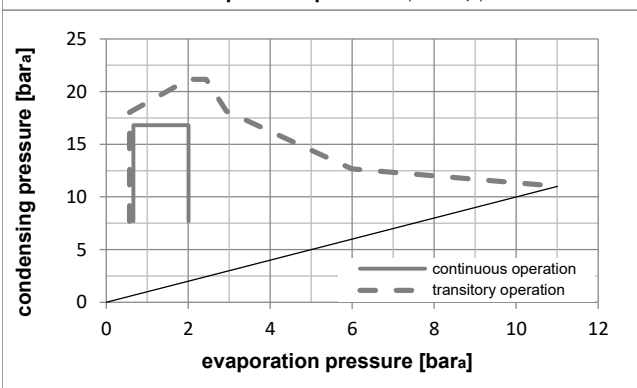
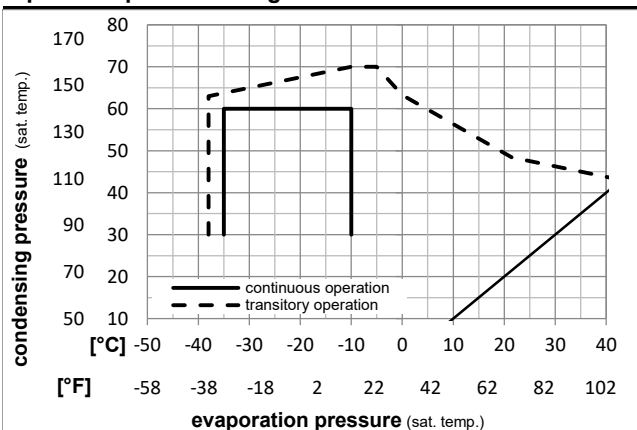

Components

a1	PTC starter (220V, 250hm, 4.8mm)	103N0018
b	plastic cover	103N2010
d	cord relief	103N1010
g	protection screen for PTC	103N0476

Alternative components

a1	PTC starter (220V, 250hm, 6.3mm)	103N0011
b	plastic cover	103N2011
d	cord relief	103N1010
g	protection screen for PTC	103N0476

Model

Designation	NL10FT	220-240V/50Hz	Conf. 1	Sales code:	105G6829
-------------	---------------	----------------------	----------------	-------------	-----------------

Optimization + standard conditions

R134a, 220V/50Hz, RSIR, static, VDE, CCC, EAC

Evaporating pressure (saturation temperature)		Condensing pressure (saturation temperature)				Cooling capacity		COP	EER	Power consumption		Current consumption		Ref. mass flow m	
pe	pc	RGT	Tliq	[W]	[Btu/h]	[kcal/h]	[W/W]	[Btu/Wh]	[kcal/Wh]	P1	I	[A]	[kg/h]		
[°C]	[°C]	[°C]	[°C]	[W]	[Btu/h]	[kcal/h]	[W/W]	[Btu/Wh]	[kcal/Wh]	[W]	[A]	[A]	[kg/h]		
-23,3 [-10]	54,4 [130]	32,2 [90]	32,2 [90]	283,8	969	244,2	1,25	4,27	1,08	227,0	1,54	5,51	ASHRAE LBP		
-25 [-13]	55 [131]	32 [89,6]	55 [131]	210,3	718	181,0	0,98	3,34	0,84	215,1	1,50	5,03	cecomaf LBP		
-35 [-31]	40 [104]	20 [68]	40 [104]	152,2	520	131,0	0,95	3,26	0,82	159,4	1,36	3,34	EN12900 LBP		
-23,3 [-10]	48,9 [120]	4,44 [40]	48,9 [120]	230,8	788	198,6	1,01	3,46	0,87	227,9	1,55	6,10	ARI540 LBP		
-23,3 [-10]	40,6 [105]	32,2 [90]	32,2 [90]	313,4	1070	269,7	1,44	4,91	1,24	217,9	1,52	6,08	AHAM LBP		
-35 [-31]	45 [113]	32 [89,6]	45 [113]	141,9	484	122,1	0,88	3,00	0,76	161,5	1,36	3,06	opt		

Performance tables

R134a, 220V/50Hz, RSIR, static, VDE, CCC, EAC

[°C / °F]	pe	Cooling capacity			COP	EER	P1		I	m	
	[°C]	[°F]	[W]	[Btu/h]	[kcal/h]	[W/W]	[Btu/Wh]	[kcal/Wh]	[W]	[A]	[kg/h]
-35	-31	141,9	484	122,1	0,88	3,00	0,76	161,5	1,36	3,06	
cond. pressure	-30	-22	189,6	648	163,2	1,03	3,51	0,88	184,6	1,42	4,10
pc= 45/113	-25	-13	248,7	849	214,0	1,16	3,98	1,00	213,5	1,50	5,39
return gas temp.	-23,3	-10	271,6	928	233,7	1,21	4,14	1,04	224,2	1,54	5,89
RGT= 32/90	-20	-4	320,6	1095	275,9	1,31	4,46	1,12	245,4	1,61	6,97
liquid temp	-15	5	407,2	1391	350,4	1,47	5,01	1,26	277,5	1,72	8,88
Tliq= 45/113	-10	14	510,1	1742	439,0	1,66	5,68	1,43	306,8	1,83	11,16
-35	-31	114,8	392	98,8	0,72	2,47	0,62	158,9	1,35	2,73	
cond. pressure	-30	-22	157,7	538	135,7	0,86	2,93	0,74	183,9	1,41	3,76
pc= 55/131	-25	-13	210,3	718	181,0	0,98	3,34	0,84	215,1	1,50	5,03
return gas temp	-23,3	-10	230,8	788	198,6	1,02	3,48	0,88	226,5	1,54	5,52
RGT= 32/90	-20	-4	274,5	937	236,2	1,10	3,76	0,95	249,4	1,62	6,58
liquid temp	-15	5	351,7	1201	302,7	1,24	4,23	1,07	284,2	1,74	8,47
Tliq= 55/131	-10	14	443,7	1515	381,9	1,40	4,79	1,21	316,4	1,87	10,73

Model

Designation	NL10FT	220-240V/50Hz	Conf. 2	Sales code:	105G6829
-------------	---------------	----------------------	----------------	-------------	-----------------

Configuration

Motorconfiguration	CSIR
Power supply (nominal)	220-240V/50Hz 1~
Refrigerant	R134a
Application	LBP
Voltage range	187-254V
Starting torque	HST
Approvals	VDE CCC EAC

Electrical accessories / wiring diagram

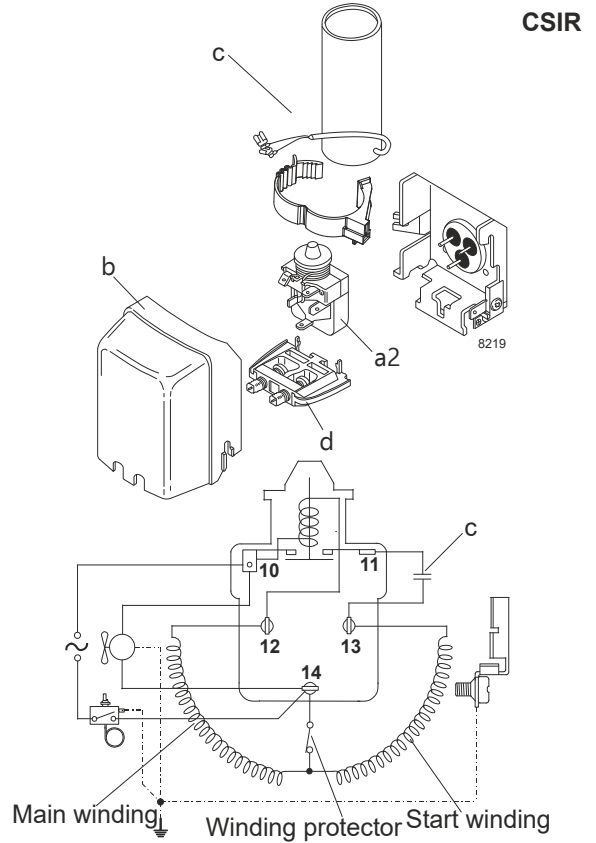

Ambient temperatures / system cooling

Ambient temperature min.:	10°C / 50°F
Ambient temperature max.:	43°C / 110°F

System cooling (n/a: outside limits)			
T ambient	LBP	MBP	HBP
32°C / 90°F	static	n/a	n/a
38°C / 100°F	fan 1,5m/s	n/a	n/a
43°C / 110°F	fan 3m/s	n/a	n/a

Operation pressure range

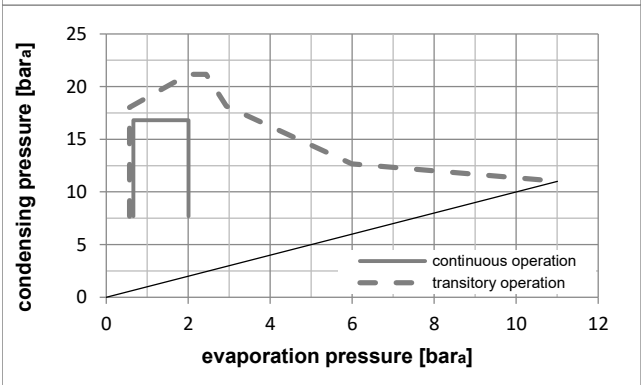
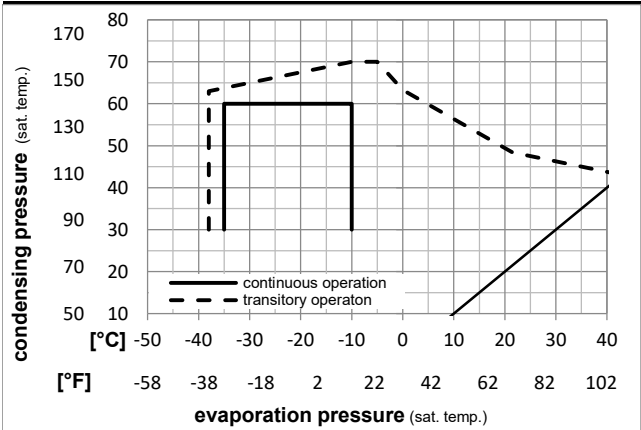

Components

a2	assy. relay	117U6002
c	start capacitor (80µF)	117U5015
b	plastic cover	103N2010
d	cord relief	103N1010

Alternative components

b	plastic cover	103N2011
---	---------------	----------

Model

Designation	NL10FT	220-240V/50Hz	Conf. 2	Sales code:	105G6829
-------------	---------------	----------------------	----------------	-------------	-----------------

Optimization + standard conditions

R134a, 220V/50Hz, CSIR, static, VDE, CCC, EAC

Evaporating pressure (saturation temperature)					Condensing pressure (saturation temperature)						Power consumption			ASHRAE LBP	
					Return gas temp.			Liquid temp.			Current consumption				Ref. mass flow m
					Cooling capacity			COP	EER	P1	I				
pe	pc	RGT	Tliq		[W]	[Btu/h]	[kcal/h]	[W/W]	[Btu/Wh]	[kcal/Wh]	[W]	[A]	[kg/h]		
[°C]	-23	54,4	32,2	32,2	283,8	969	244,2	1,25	4,27	1,08	227,0	1,54	5,51	ASHRAE LBP	
[°F]	-10	130	90	90											
[°C]	-25	55	32	55	210,3	718	181,0	0,98	3,34	0,84	215,1	1,50	5,03	cecomaf LBP	
[°F]	-13	131	89,6	131											
[°C]	-35	40	20	40	152,2	520	131,0	0,95	3,26	0,82	159,4	1,36	3,34	EN12900 LBP	
[°F]	-31	104	68	104											
[°C]	-23	48,9	4,44	48,9	230,8	788	198,6	1,01	3,46	0,87	227,9	1,55	6,10	ARI540 LBP	
[°F]	-10	120	40	120											
[°C]	-23	40,6	32,2	32,2	313,4	1070	269,7	1,44	4,91	1,24	217,9	1,52	6,08	AHAM LBP	
[°F]	-10	105	90	90											
[°C]	-35	45	32	45	141,9	484	122,1	0,88	3,00	0,76	161,5	1,36	3,06	opt	
[°F]	-31	113	89,6	113											

Performance tables

R134a, 220V/50Hz, CSIR, static, VDE, CCC, EAC

	pe		Cooling capacity			COP	EER	P1	I	m	
	[°C]	[°F]	[W]	[Btu/h]	[kcal/h]	[W/W]	[Btu/Wh]	[kcal/Wh]	[W]	[A]	[kg/h]
[°C / °F]	-35	-31	141,9	484	122,1	0,88	3,00	0,76	161,5	1,36	3,06
cond. pressure	-30	-22	189,6	648	163,2	1,03	3,51	0,88	184,6	1,42	4,10
pc= 45/113	-25	-13	248,7	849	214,0	1,16	3,98	1,00	213,5	1,50	5,39
return gas temp.	-23	-10	271,6	928	233,7	1,21	4,14	1,04	224,2	1,54	5,89
RGT= 32/90	-20	-4	320,6	1095	275,9	1,31	4,46	1,12	245,4	1,61	6,97
liquid temp	-15	5	407,2	1391	350,4	1,47	5,01	1,26	277,5	1,72	8,88
Tliq= 45/113	-10	14	510,1	1742	439,0	1,66	5,68	1,43	306,8	1,83	11,16
[°C / °F]	-35	-31	114,8	392	98,8	0,72	2,47	0,62	158,9	1,35	2,73
cond. pressure	-30	-22	157,7	538	135,7	0,86	2,93	0,74	183,9	1,41	3,76
pc= 55/131	-25	-13	210,3	718	181,0	0,98	3,34	0,84	215,1	1,50	5,03
return gas temp	-23	-10	230,8	788	198,6	1,02	3,48	0,88	226,5	1,54	5,52
RGT= 32/90	-20	-4	274,5	937	236,2	1,10	3,76	0,95	249,4	1,62	6,58
liquid temp	-15	5	351,7	1201	302,7	1,24	4,23	1,07	284,2	1,74	8,47
Tliq= 55/131	-10	14	443,7	1515	381,9	1,40	4,79	1,21	316,4	1,87	10,73