

Model

| | | | | |
|-------------|-----------------|------------------------------|-------------|-----------------|
| Designation | NL6.1MLX | 220V/50Hz 1~208-230V/60Hz 1~ | Sales code: | 105F3610 |
|-------------|-----------------|------------------------------|-------------|-----------------|

Compressor design

| | | | |
|----------------------------|---------------------------------|-----------------------|---------------------------------|
| Oil type | Polyolester | Refrigerant(s) | R404A, R507 |
| Oil viscosity | 32cST | Displacement | 6,13cm ³ / 0,37cu.in |
| Oil quantity | 298cm ³ / 10,1fl.oz | Compressors on pallet | 80 |
| Refr. charge - tech. limit | 400g / 14,1oz | | |
| Free gas volume comp. | 2310cm ³ / 78,1fl.oz | | |
| Weight | 10,5kg / 23,1lbs | | |
| Motor protection | 1# internal | | |
| Winding resistance main | 6,1Ω (at 25°C) | | |
| Winding resistance aux | 17,5Ω (at 25°C) | | |
| Max. winding temp. | 125°C / 257°F | | |
| Max. discharge temp. | 130°C / 266°F | | |



General - Configurations with NL6.1MLX

| | Conf. 1 | Conf. 2 |
|------------------------|-------------------|-------------------|
| Motorconfiguration | CSIR | CSIR |
| Power supply (nominal) | 220-240V/50Hz | 208-230V/60Hz |
| Number of phases | 1 | 1 |
| Voltage range | 187-254V | 187-254V |
| Approvals | VDE, CCC, EAC, UL | VDE, CCC, EAC, UL |
| Starting torque | HST | HST |
| Note | - / - | |

Applications with NL6.1MLX

| | Conf. 1 | Conf. 2 |
|-------------------------|----------------|----------------|
| Refrigerant | R404A | R404A |
| Application | MBP | MBP |
| System cooling | fan 3m/s | fan 3m/s |
| Hot gas defrost | - / - | - / - |
| Long interval pull down | OK | OK |

Electrical data - Configurations with NL6.1MLX

| | Conf. 1 | Conf. 2 |
|------------------------------|----------------|----------------|
| Starting device type | relay | relay |
| Run capacitor | - / - | - / - |
| Start capacitor | 80μF | 80μF |
| LRA (locked rotor amps / 4s) | 16,6A | 16,1A |
| RLA (rated load amps / 1s) | 2,8A | 2,4A |
| Cut in current | 17A | 15,5A |

Model

| | | | | |
|-------------|-----------------|------------------------------|-------------|-----------------|
| Designation | NL6.1MLX | 220V/50Hz 1~208-230V/60Hz 1~ | Sales code: | 105F3610 |
|-------------|-----------------|------------------------------|-------------|-----------------|

Compressor dimensions

| | | |
|----------------|-------------------|----------------|
| Housing | A Height | 203mm / 7,99in |
| | B Height | 197mm / 7,76in |
| | C Length shell | 205mm / 8,07in |
| | D Length w. cover | 254mm / 10in |
| | E Width | 166mm / 6,54in |

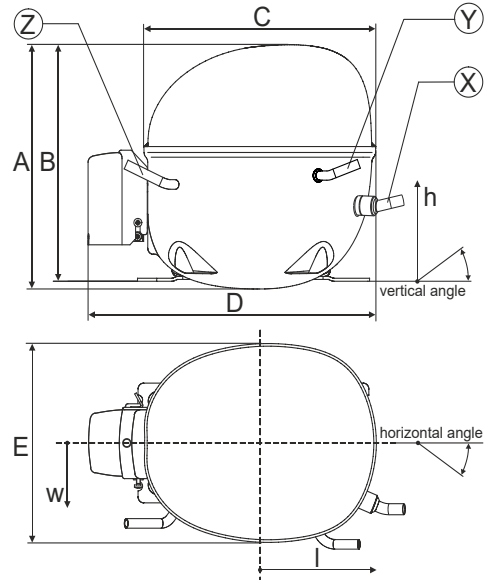

| Connectors | | Suction | | Discharge | | Process | |
|-------------------|----------------------------|----------------|--------------|------------------|--------------|----------------|--------------|
| | | X | Y | Z | X | Y | Z |
| Diameter | [mm] | øi 9,61-9,79 | øi 6,41-6,59 | øi 6,41-6,59 | øi 6,41-6,59 | øi 6,41-6,59 | øi 6,41-6,59 |
| | (i:inside, o:outside) [in] | øi 0,38-0,39 | øi 0,25-0,26 | øi 0,25-0,26 | øi 0,25-0,26 | øi 0,25-0,26 | øi 0,25-0,26 |
| Material | | copper | copper | copper | copper | copper | copper |
| Horizontal angle | ±2° | 0° | 0° | 0° | 0° | 0° | 0° |
| Vertical angle | ±2° | 15° | 35° | 35° | 155° | 155° | 155° |
| Position l/h/w | [mm] | 126/76/78 | 133/103/54 | -107/94/72 | 126/76/78 | 133/103/54 | -107/94/72 |
| | [in] | 4,9/3/3,1 | 5,2/4/2,1 | -4,2/3,7/2,8 | 4,9/3/3,1 | 5,2/4/2,1 | -4,2/3,7/2,8 |
| Straight tube l. | [mm] | 12 | 12 | 12 | 12 | 12 | 12 |
| | [in] | 0,5 | 0,5 | 0,5 | 0,5 | 0,5 | 0,5 |

Compressor fixation

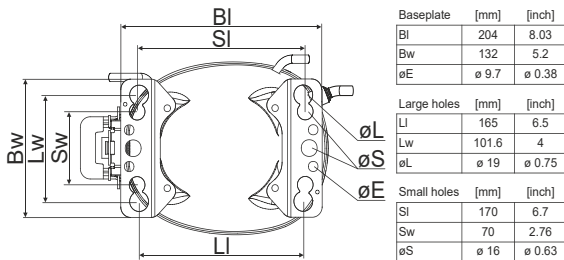

Bolt joint

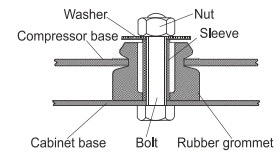

Snap-on

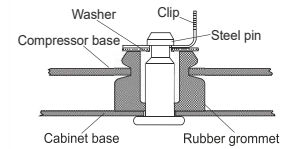

| Mounting accessories | one comp. | multi pack |
|-----------------------------|-----------|------------|
| Bolt joint M6 ø16mm | 118-1917 | 118-1918 |
| Bolt joint ø1/4" ø16mm | 118-1946 | |
| Bolt joint ø1/4" ø19mm | 118-1949 | |
| Snap-on ø7,3 ø16mm | 118-1947 | 118-1919 |

Application notes

LRA value on compressor label and datasheet may differ due to different test conditions for UL approval.

Model

| | | | | | |
|-------------|-----------------|----------------------|----------------|-------------|-----------------|
| Designation | NL6.1MLX | 220-240V/50Hz | Conf. 1 | Sales code: | 105F3610 |
|-------------|-----------------|----------------------|----------------|-------------|-----------------|

Configuration

| | |
|------------------------|-----------------------|
| Motorconfiguration | CSIR |
| Power supply (nominal) | 220-240V/50Hz 1~ |
| Refrigerant | R404A |
| Application | MBP |
| Voltage range | 187-254V |
| Starting torque | HST |
| Approvals | VDE (2) |
| | (1): Made in China |
| | CCC (1),(2) |
| | (2): Made in Slovakia |
| | EAC (1),(2) |
| | UL (1),(2) |

Electrical accessories / wiring diagram

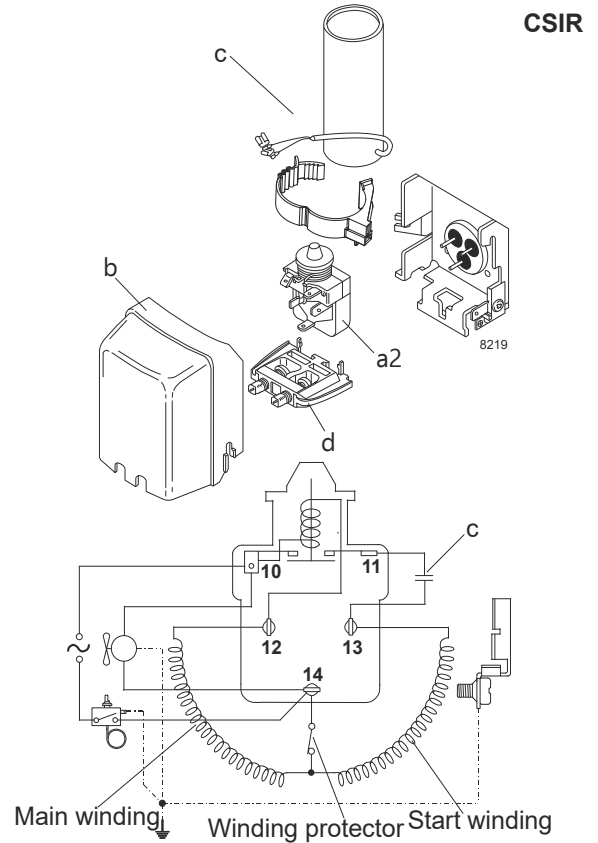

Ambient temperatures / system cooling

| | |
|---------------------------|--------------|
| Ambient temperature min.: | 10°C / 50°F |
| Ambient temperature max.: | 43°C / 110°F |

| System cooling (n/a: outside limits) | | | |
|--------------------------------------|-----|----------|-----|
| T ambient | LBP | MBP | HBP |
| 32°C / 90°F | n/a | fan 3m/s | n/a |
| 38°C / 100°F | n/a | fan 3m/s | n/a |
| 43°C / 110°F | n/a | fan 3m/s | n/a |

Operation pressure range

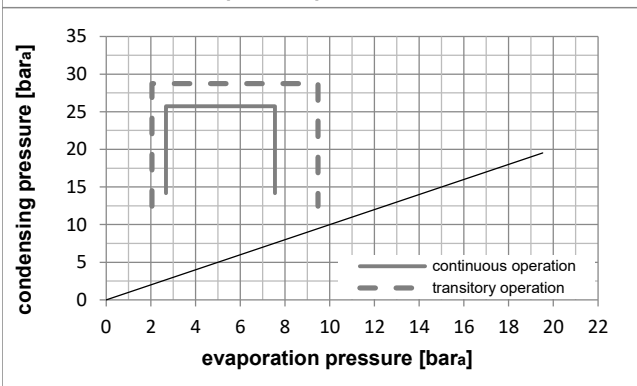
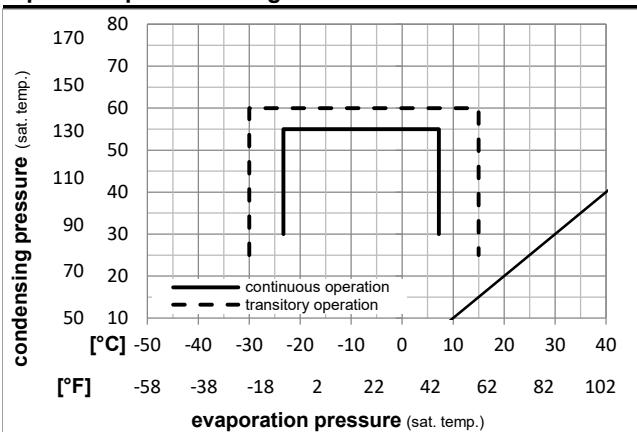

Components

| | | |
|----|------------------------|----------|
| a2 | relay | 117U6022 |
| c | start capacitor (80µF) | 117U5015 |
| b | plastic cover | 103N2011 |
| d | cord relief | 103N1010 |

Model

Designation **NL6.1MLX 220-240V/50Hz** Conf. 1 Sales code: **105F3610**

Optimization + standard conditions

R404A, 220V/50Hz, CSIR, fan 3m/s, VDE, CCC, EAC, UL

| Evaporating pressure (saturation temperature) | | | | | | | | | | | | | | | |
|---|-------|------|------|------|-------|---------|----------|-------|----------|---------------------|-------|------|--------|-------------|--|
| Condensing pressure (saturation temperature) | | | | | | | | | | Power consumption | | | | | |
| Return gas temp. | | | | | | | | | | Current consumption | | | | | |
| Liquid temp. | | | | | | | | | | Ref. mass flow | | | | | |
| Cooling capacity | | | | | | | | | | COP | EER | P1 | I | m | |
| | pe | pc | RGT | Tliq | [W] | [Btu/h] | [kcal/h] | [W/W] | [Btu/Wh] | [kcal/Wh] | [W] | [A] | [kg/h] | | |
| [°C] | -6,66 | 54,4 | 35 | 46,1 | 569,4 | 1945 | 490,1 | 1,61 | 5,51 | 1,39 | 352,8 | 2,43 | 15,67 | ASHRAE MBP | |
| [°F] | 20 | 130 | 95 | 115 | | | | | | | | | | | |
| [°C] | -10 | 55 | 32 | 55 | 422,4 | 1442 | 363,5 | 1,26 | 4,30 | 1,08 | 335,8 | 2,38 | 13,52 | cecomaf MBP | |
| [°F] | 14 | 131 | 89,6 | 131 | | | | | | | | | | | |
| [°C] | -10 | 45 | 20 | 45 | 499,3 | 1705 | 429,7 | 1,60 | 5,47 | 1,38 | 311,9 | 2,29 | 15,04 | EN12900 MBP | |
| [°F] | 14 | 113 | 68 | 113 | | | | | | | | | | | |
| [°C] | -6,66 | 48,9 | 18,3 | 48,9 | 520,3 | 1777 | 447,8 | 1,54 | 5,27 | 1,33 | 337,3 | 2,37 | 17,00 | ARI540 MBP | |
| [°F] | 20 | 120 | 65 | 120 | | | | | | | | | | | |
| [°C] | -10 | 45 | 32 | 45 | 529,9 | 1810 | 456,0 | 1,70 | 5,80 | 1,46 | 311,9 | 2,29 | 14,59 | opt | |
| [°F] | 14 | 113 | 89,6 | 113 | | | | | | | | | | | |
| [°C] | -25 | 45 | 32 | 45 | 256,1 | 875 | 220,4 | 1,09 | 3,73 | 0,94 | 234,1 | 2,10 | 6,91 | opt | |
| [°F] | -13 | 113 | 89,6 | 113 | | | | | | | | | | | |

Performance tables

R404A, 220V/50Hz, CSIR, fan 3m/s, VDE, CCC, EAC, UL

| | pe | Cooling capacity | | | COP | EER | P1 | I | m | | |
|------------------|-------|------------------|--------|---------|----------|-------|----------|-----------|-------|------|--------|
| | [°C] | [°F] | [W] | [Btu/h] | [kcal/h] | [W/W] | [Btu/Wh] | [kcal/Wh] | [W] | [A] | [kg/h] |
| [°C / °F] | -23,3 | -10 | 281,4 | 961 | 242,2 | 1,16 | 3,95 | 0,99 | 243,6 | 2,12 | 7,61 |
| cond. pressure | -20 | -4 | 334,4 | 1142 | 287,8 | 1,28 | 4,37 | 1,10 | 261,5 | 2,16 | 9,07 |
| pc= 45/113 | -15 | 5 | 425,1 | 1452 | 365,9 | 1,48 | 5,05 | 1,27 | 287,4 | 2,22 | 11,61 |
| return gas temp. | -10 | 14 | 529,9 | 1810 | 456,0 | 1,70 | 5,80 | 1,46 | 311,9 | 2,29 | 14,59 |
| RGT= 32/90 | -5 | 23 | 650,5 | 2221 | 559,8 | 1,94 | 6,63 | 1,67 | 334,8 | 2,36 | 18,08 |
| liquid temp | 0 | 32 | 788,6 | 2693 | 678,7 | 2,22 | 7,56 | 1,91 | 356,0 | 2,43 | 22,17 |
| Tliq= 45/113 | 7,2 | 45 | 1021,9 | 3490 | 879,4 | 2,67 | 9,11 | 2,29 | 383,2 | 2,54 | 29,30 |
| [°C / °F] | -23,3 | -10 | 214,5 | 733 | 184,6 | 0,84 | 2,87 | 0,72 | 255,4 | 2,18 | 6,72 |
| cond. pressure | -20 | -4 | 259,5 | 886 | 223,3 | 0,94 | 3,21 | 0,81 | 276,1 | 2,23 | 8,16 |
| pc= 55/131 | -15 | 5 | 335,4 | 1146 | 288,7 | 1,09 | 3,74 | 0,94 | 306,6 | 2,30 | 10,64 |
| return gas temp | -10 | 14 | 422,4 | 1442 | 363,5 | 1,26 | 4,30 | 1,08 | 335,8 | 2,38 | 13,52 |
| RGT= 32/90 | -5 | 23 | 522,0 | 1783 | 449,3 | 1,44 | 4,90 | 1,24 | 363,6 | 2,47 | 16,90 |
| liquid temp | 0 | 32 | 636,2 | 2173 | 547,5 | 1,63 | 5,57 | 1,40 | 389,9 | 2,55 | 20,86 |
| Tliq= 55/131 | 7,2 | 45 | 829,4 | 2833 | 713,8 | 1,95 | 6,67 | 1,68 | 424,8 | 2,69 | 27,84 |

Model

| | | | | | |
|-------------|-----------------|----------------------|----------------|-------------|-----------------|
| Designation | NL6.1MLX | 208-230V/60Hz | Conf. 2 | Sales code: | 105F3610 |
|-------------|-----------------|----------------------|----------------|-------------|-----------------|

Configuration

| | |
|------------------------|-----------------------------------|
| Motorconfiguration | CSIR |
| Power supply (nominal) | 208-230V/60Hz 1~ |
| Refrigerant | R404A |
| Application | MBP |
| Voltage range | 187-254V |
| Starting torque | HST |
| Approvals | VDE (2) |
| | (1): Made in China CCC (1),(2) |
| | (2): Made in Slovakia EAC (1),(2) |
| | UL (1),(2) |

Electrical accessories / wiring diagram

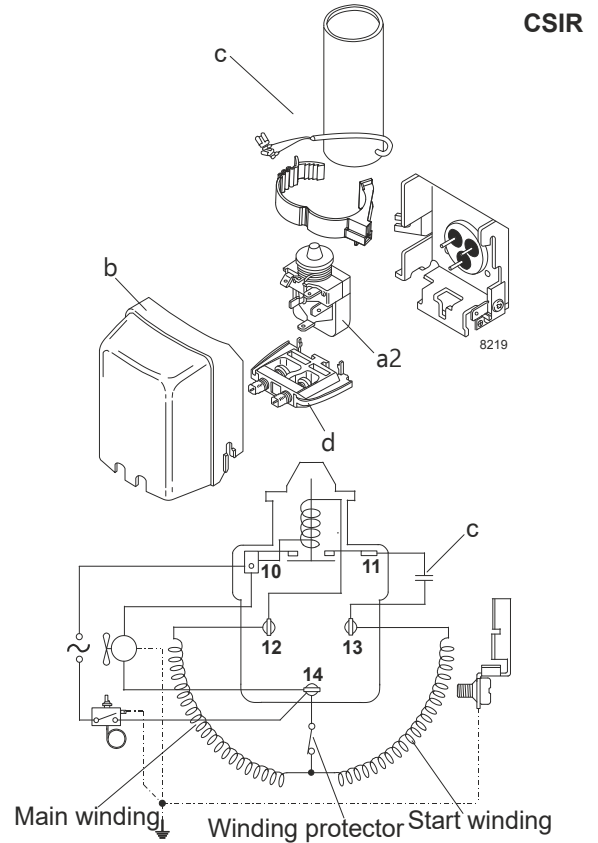

Ambient temperatures / system cooling

| | |
|---------------------------|--------------|
| Ambient temperature min.: | 10°C / 50°F |
| Ambient temperature max.: | 43°C / 110°F |

| System cooling (n/a: outside limits) | | | |
|--------------------------------------|-----|----------|-----|
| T ambient | LBP | MBP | HBP |
| 32°C / 90°F | n/a | fan 3m/s | n/a |
| 38°C / 100°F | n/a | fan 3m/s | n/a |
| 43°C / 110°F | n/a | fan 3m/s | n/a |

Operation pressure range

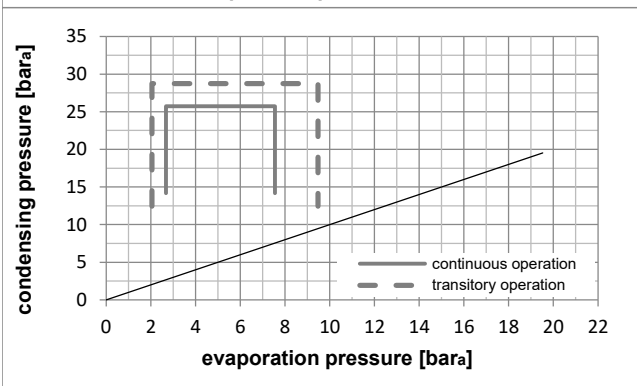
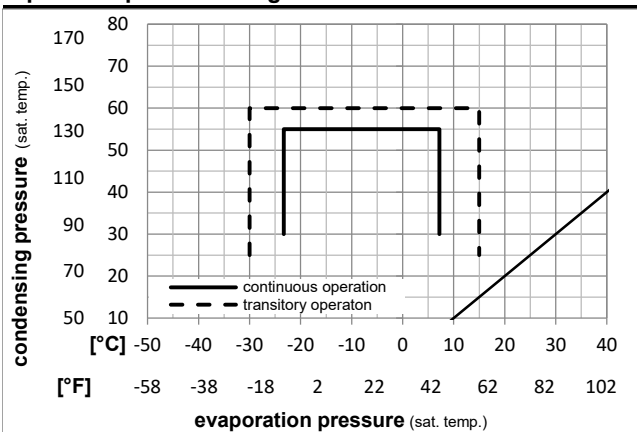

Components

| | | |
|----|------------------------|----------|
| a2 | relay | 117U6022 |
| c | start capacitor (80µF) | 117U5015 |
| b | plastic cover | 103N2011 |
| d | cord relief | 103N1010 |

Model

| | | | | | |
|-------------|-----------------|----------------------|----------------|-------------|-----------------|
| Designation | NL6.1MLX | 208-230V/60Hz | Conf. 2 | Sales code: | 105F3610 |
|-------------|-----------------|----------------------|----------------|-------------|-----------------|

Optimization + standard conditions

R404A, 230V/60Hz, CSIR, fan 3m/s, VDE, CCC, EAC, UL

| | | Evaporating pressure (saturation temperature) | | | Condensing pressure (saturation temperature) | | | Return gas temp. | | Liquid temp. | | Cooling capacity | | | COP | EER | Power consumption | | | ASHRAE MBP |
|------|------|---|-----|------|--|------|---------|------------------|-------|--------------|-----------|------------------|------|--------|---------------------|-------|-------------------|----------------|----------------|---------------|
| | | pe | pc | RGT | Tliq | [W] | [Btu/h] | [kcal/h] | [W/W] | [Btu/Wh] | [kcal/Wh] | P1 | I | m | Current consumption | | | cecomaf MBP | | |
| [°C] | [°F] | | | | | | | | | | | [W] | [A] | [kg/h] | | | | | EN12900 MBP | |
| -6,7 | 20 | 54,4 | 130 | 35 | 95 | 46,1 | 115 | 676,9 | 2312 | 582,6 | 1,62 | 5,52 | 1,39 | 419,0 | 2,39 | 18,63 | | | | |
| -10 | 14 | 55 | 131 | 32 | 89,6 | 55 | 131 | 502,8 | 1717 | 432,7 | 1,28 | 4,36 | 1,10 | 394,1 | 2,30 | 16,09 | | | | |
| -10 | 14 | 45 | 113 | 20 | 68 | 45 | 113 | 593,2 | 2026 | 510,5 | 1,61 | 5,51 | 1,39 | 367,6 | 2,20 | 17,87 | | | | |
| -6,7 | 20 | 48,9 | 120 | 18,3 | 65 | 48,9 | 120 | 617,8 | 2110 | 531,7 | 1,54 | 5,26 | 1,33 | 400,8 | 2,33 | 20,19 | | | | |
| -10 | 14 | 45 | 113 | 32 | 89,6 | 45 | 113 | 629,6 | 2150 | 541,8 | 1,71 | 5,85 | 1,47 | 367,6 | 2,20 | 17,34 | opt | | | |
| -25 | -13 | 45 | 113 | 32 | 89,6 | 45 | 113 | 309,2 | 1056 | 266,1 | 1,17 | 4,00 | 1,01 | 264,2 | 1,84 | 8,34 | opt | | | |

Performance tables

R404A, 230V/60Hz, CSIR, fan 3m/s, VDE, CCC, EAC, UL

| | pe | | Cooling capacity | | | COP | EER | P1 | I | m | |
|------------------|------|------|------------------|---------|----------|-------|----------|-----------|-------|------|--------|
| | [°C] | [°F] | [W] | [Btu/h] | [kcal/h] | [W/W] | [Btu/Wh] | [kcal/Wh] | [W] | [A] | [kg/h] |
| [°C / °F] | -23 | -10 | 338,9 | 1157 | 291,7 | 1,23 | 4,19 | 1,05 | 276,5 | 1,88 | 9,16 |
| cond. pressure | -20 | -4 | 400,9 | 1369 | 345,0 | 1,34 | 4,57 | 1,15 | 299,9 | 1,96 | 10,88 |
| pc= 45/113 | -15 | 5 | 507,0 | 1732 | 436,4 | 1,52 | 5,18 | 1,31 | 334,3 | 2,08 | 13,85 |
| return gas temp. | -10 | 14 | 629,6 | 2150 | 541,8 | 1,71 | 5,85 | 1,47 | 367,6 | 2,20 | 17,34 |
| RGT= 32/90 | -5 | 23 | 770,7 | 2632 | 663,2 | 1,93 | 6,58 | 1,66 | 400,0 | 2,33 | 21,42 |
| liquid temp | 0 | 32 | 932,3 | 3184 | 802,3 | 2,16 | 7,38 | 1,86 | 431,5 | 2,46 | 26,21 |
| Tliq= 45/113 | 7,2 | 45 | 1205,2 | 4116 | 1037,2 | 2,53 | 8,65 | 2,18 | 475,6 | 2,66 | 34,56 |
| [°C / °F] | -23 | -10 | 257,8 | 881 | 221,9 | 0,91 | 3,12 | 0,79 | 282,3 | 1,89 | 8,08 |
| cond. pressure | -20 | -4 | 310,8 | 1061 | 267,5 | 1,00 | 3,41 | 0,86 | 310,8 | 1,99 | 9,78 |
| pc= 55/131 | -15 | 5 | 400,3 | 1367 | 344,5 | 1,13 | 3,87 | 0,98 | 353,1 | 2,14 | 12,69 |
| return gas temp | -10 | 14 | 502,8 | 1717 | 432,7 | 1,28 | 4,36 | 1,10 | 394,1 | 2,30 | 16,09 |
| RGT= 32/90 | -5 | 23 | 620,3 | 2118 | 533,8 | 1,43 | 4,88 | 1,23 | 434,2 | 2,45 | 20,08 |
| liquid temp | 0 | 32 | 754,8 | 2578 | 649,6 | 1,59 | 5,45 | 1,37 | 473,3 | 2,62 | 24,75 |
| Tliq= 55/131 | 7,2 | 45 | 982,7 | 3356 | 845,7 | 1,86 | 6,35 | 1,60 | 528,5 | 2,85 | 32,98 |