

Model

Designation	NL7.3MF	220-240V/50Hz 1~ 208-230V/60Hz 1~	Sales code:	105G6772
-------------	----------------	-----------------------------------	-------------	-----------------

Compressor design

Oil type	Polyolester	Refrigerant(s)	R134a, R513A
Oil viscosity	32cST	Displacement	7,27cm ³ / 0,44cu.in
Oil quantity	268cm ³ / 9,1fl.oz	Compressors on pallet	80
Refr. charge - tech. limit	600g / 21,2oz		
Free gas volume comp.	2360cm ³ / 79,8fl.oz		
Weight	10kg / 22lbs		
Motor protection	1# internal		
Winding resistance main	8,3Ω (at 25°C)		
Winding resistance aux	11,8Ω (at 25°C)		
Max. winding temp.	125°C / 257°F		
Max. discharge temp.	130°C / 266°F		
Additional note	See data for different refrigerant attached		



General - Configurations with NL7.3MF

	Conf. 1	Conf. 2	Conf. 3
Motorconfiguration	RSIR	CSIR	CSIR
Power supply (nominal)	220-240V/50Hz	220-240V/50Hz	208-230V/60Hz
Number of phases	1	1	1
Voltage range	187-254V	187-254V	187-254V
Approvals	VDE, UL, CCC, EAC, KC	VDE, UL, CCC, EAC, KC	VDE, UL, CCC, EAC, KC
Starting torque	LST	HST	HST
Note	- / -		

Applications with NL7.3MF

	Conf. 1	Conf. 2	Conf. 3
Refrigerant	R134a	R134a	R134a
Application	MBP	MBP	MBP
System cooling	fan 3m/s	fan 3m/s	fan 1,5m/s
Hot gas defrost	- / -	- / -	- / -
Long interval pull down	OK	OK	OK

Electrical data - Configurations with NL7.3MF

	Conf. 1	Conf. 2	Conf. 3
Starting device type	PTC	relay	relay
Run capacitor	- / -	- / -	- / -
Start capacitor	- / -	80μF	80μF
LRA (locked rotor amps / 4s)	10,2A	10,7A	10,8A
RLA (rated load amps / 1s)	2,1A	2,1A	1,8A
Cut in current	15,1A	10,7A	10,8A

Model

Designation

NL7.3MF

220-240V/50Hz 1~ 208-230V/60Hz 1~

Sales code:

105G6772

Compressor dimensions

Housing	A Height	197mm / 7,76in
	B Height	191mm / 7,52in
	C Length shell	205mm / 8,07in
	D Length w. cover	254mm / 10in
	E Width	166mm / 6,54in

Connectors		Suction	Discharge	Process
		X	Y	Z
Diameter	[mm]	øi 8,11-8,29	øi 6,11-6,29	øi 6,11-6,29
	(i:inside, o:outside) [in]	øi 0,32-0,33	øi 0,24-0,25	øi 0,24-0,25
Material		copper	copper	copper
Horizontal angle	±2°	0°	0°	0°
Vertical angle	±2°	15°	35°	155°
Position l/h/w	[mm]	126/76/78	133/103/54	-107/94/72
	[in]	4,9/3/3,1	5,2/4/2,1	-4,2/3,7/2,8
Straight tube l.	[mm]	12	12	12
	[in]	0,5	0,5	0,5

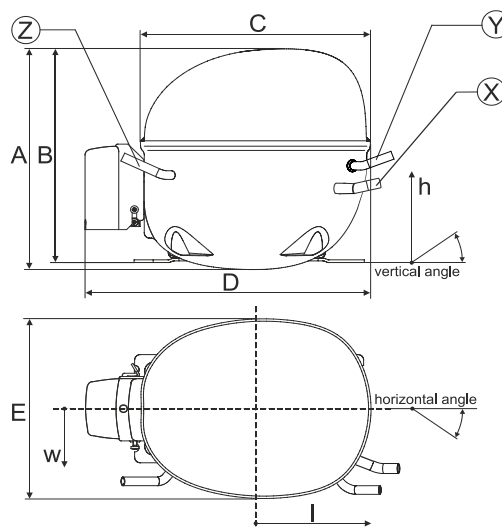

Compressor fixation

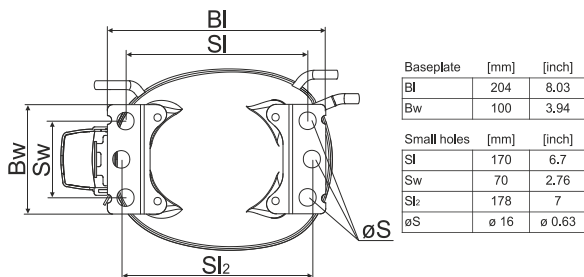

Bolt joint

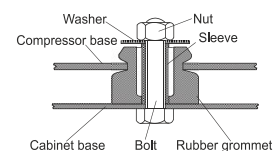

Snap-on

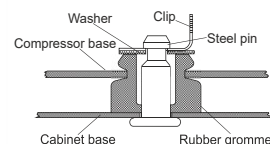

Mounting accessories

	one comp.	multi pack
Bolt joint M6 ø16mm	118-1917	118-1918
Bolt joint ø1/4" ø16mm	118-1946	
Bolt joint ø1/4" ø19mm	118-1949	
Snap-on ø7,3 ø16mm	118-1947	118-1919

Application notes

LRA value on compressor label and datasheet may differ due to different test conditions for UL approval.

CSIR strongly recommended for 60Hz

F2 for 230-240V 50Hz nominal below -12°C evaporating temp

Provision for PE Grounding is located at the PE Stamp on the compressor

Model

Designation	NL7.3MF	220-240V/50Hz	Conf. 1	Sales code:	105G6772
-------------	----------------	----------------------	----------------	-------------	-----------------

Configuration

Motorconfiguration	RSIR
Power supply (nominal)	220-240V/50Hz 1~
Refrigerant	R134a
Application	MBP
Voltage range	187-254V
Starting torque	LST
Approvals	VDE UL CCC EAC KC

Electrical accessories / wiring diagram

RSIR

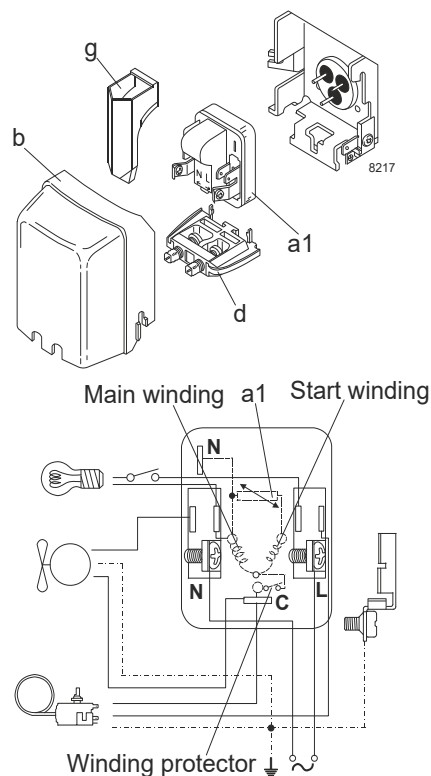

Ambient/ machine room temperatures minimum /maximum

Ambient temperature range:	10 - 43°C / 50 - 110°F
Machine room temperature range:	10 - 48°C / 50 - 119°F
Compressor cooling:	fan 1,5m/s

Operation Limits

Operation pressure range

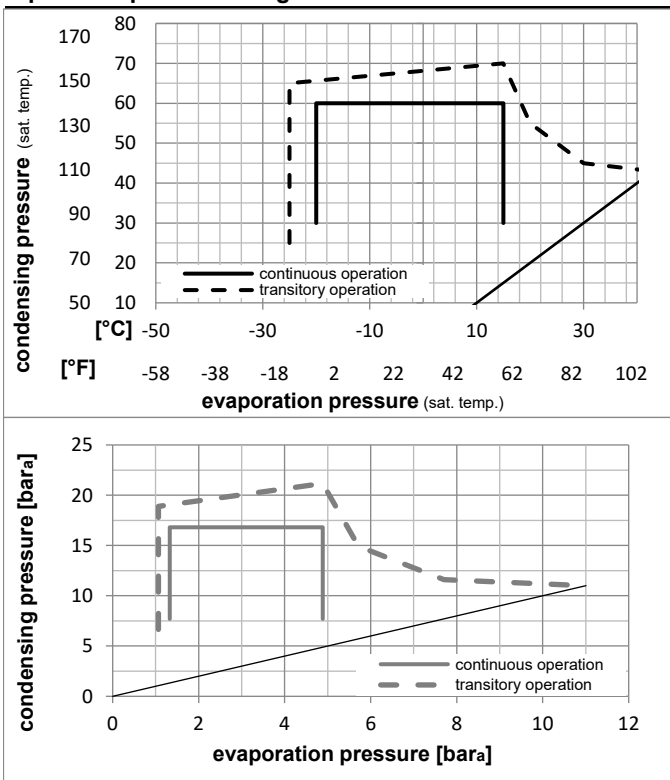

Components

a1	PTC starter (220V, 250hm, 4.8mm)	103N0018
b	plastic cover	103N2011
d	cord relief	103N1010
g	protection screen for PTC	103N0476

Alternative components

a1	PTC starter (220V, 250hm, 6.3mm)	103N0011
b	plastic cover	103N2010
d	cord relief	103N1010
g	protection screen for PTC	103N0476

Model

Designation **NL7.3MF** **220-240V/50Hz** Conf. 1 Sales code: **105G6772**

Optimization + standard conditions

R134a, 220V/50Hz, RSIR, fan 1,5m/s, VDE, UL, CCC, EAC, KC

	Evaporating pressure (saturation temperature)				Condensing pressure (saturation temperature)			Return gas temp.	Liquid temp.	Cooling capacity	COP	EER	Power consumption			ASHRAE MBP
	pe	pc	RGT	Tliq	[W]	[Btu/h]	[kcal/h]						P1	I	Ref. mass flow	
[°C]	-7	54	35	46	395,0	1349	340,0	1,64	5,59	1,41	241,4	1,71	8,62			
[°F]	20	130	95	115												
	-10	55	32	55	304,1	1039	261,7	1,34	4,58	1,15	226,8	1,67	7,35	cecomaf MBP		
	-10	45	20	45	347,1	1185	298,7	1,62	5,52	1,39	214,8	1,63	8,12	EN12900 MBP		
	-10	49	18	49	377,8	1290	325,1	1,62	5,53	1,39	233,4	1,69	9,33	ARI540 MBP		
	-10	45	32	45	360,1	1230	309,9	1,68	5,72	1,44	214,8	1,63	7,88	opt		
	-25	45	32	45	160,7	549	138,3	1,03	3,50	0,88	156,6	1,54	3,48	opt		

Performance tables

R134a, 220V/50Hz, RSIR, fan 1,5m/s, VDE, UL, CCC, EAC, KC

	pe		Cooling capacity			COP	EER	P1	I	m	
	[°C]	[°F]	[W]	[Btu/h]	[kcal/h]	[W/W]	[Btu/Wh]	[kcal/Wh]	[W]	[A]	[kg/h]
[°C / °F]	-20	-4	215,3	735	185,3	1,22	4,18	1,05	176,0	1,56	4,68
cond. pressure	-15	5	281,3	961	242,0	1,44	4,92	1,24	195,3	1,59	6,13
pc= 45/113	-10	14	360,1	1230	309,9	1,68	5,72	1,44	214,8	1,63	7,88
return gas temp.	-5	23	453,4	1549	390,2	1,93	6,60	1,66	234,8	1,69	9,97
RGT= 32/90	0	32	562,9	1923	484,5	2,20	7,52	1,90	255,7	1,76	12,45
liquid temp	5	41	690,2	2357	594,0	2,49	8,49	2,14	277,7	1,84	15,37
Tliq= 45/113	15	59	1004,7	3431	864,7	3,08	10,51	2,65	326,6	2,04	22,76
[°C / °F]	-20	-4	179,3	612	154,3	0,99	3,37	0,85	181,5	1,57	4,30
cond. pressure	-15	5	236,2	807	203,3	1,16	3,95	1,00	204,1	1,61	5,69
pc= 55/131	-10	14	304,1	1039	261,7	1,34	4,58	1,15	226,8	1,67	7,35
return gas temp	-5	23	384,8	1314	331,1	1,54	5,26	1,32	249,9	1,74	9,35
RGT= 32/90	0	32	479,7	1638	412,8	1,75	5,99	1,51	273,7	1,82	11,73
liquid temp	5	41	590,5	2017	508,2	1,98	6,76	1,70	298,5	1,91	14,55
Tliq= 55/131	15	59	866,6	2960	745,8	2,46	8,40	2,12	352,5	2,14	21,77

Model

Designation	NL7.3MF	220-240V/50Hz	Conf. 2	Sales code:	105G6772
-------------	----------------	----------------------	----------------	-------------	-----------------

Configuration

Motorconfiguration	CSIR
Power supply (nominal)	220-240V/50Hz 1~
Refrigerant	R134a
Application	MBP
Voltage range	187-254V
Starting torque	HST
Approvals	VDE UL CCC EAC KC

Electrical accessories / wiring diagram

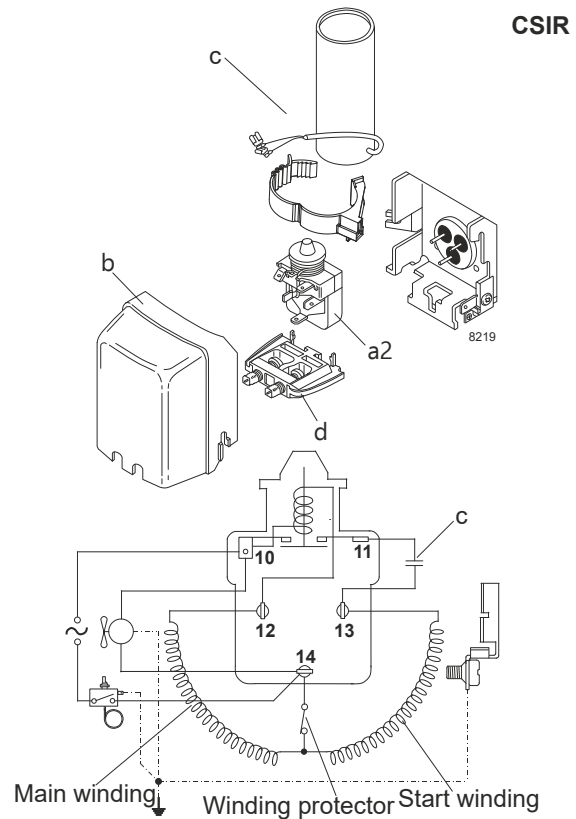

Ambient/ machine room temperatures minimum /maximum

Ambient temperature range:	10 - 43°C / 50 - 110°F
Machine room temperature range:	10 - 48°C / 50 - 119°F
Compressor cooling:	fan 1,5m/s

Operation Limits

Operation pressure range

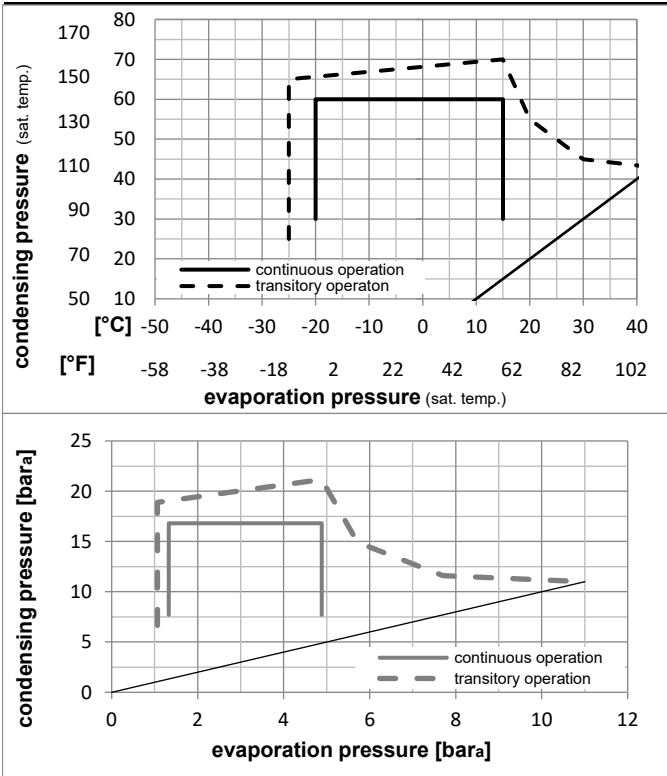

Components

a2	relay	117U6016
c	start capacitor (80µF)	117U5015
b	plastic cover	103N2011
d	cord relief	103N1010

Model

Designation **NL7.3MF** **220-240V/50Hz** Conf. 2 Sales code: **105G6772**

Optimization + standard conditions

R134a, 220V/50Hz, CSIR, fan 1,5m/s, VDE, UL, CCC, EAC, KC

		Evaporating pressure (saturation temperature)				Condensing pressure (saturation temperature)						Power consumption			
		Return gas temp.		Liquid temp.		Cooling capacity		COP	EER		P1	I	Ref. mass flow		
		pe	pc	RGT	Tliq	[W]	[Btu/h]	[kcal/h]	[W/W]	[Btu/Wh]	[kcal/Wh]	[W]	[A]	[kg/h]	
[°C]	-7	54	35	46	395,0	1349	340,0	1,64	5,59	1,41	241,4	1,71	8,62	ASHRAE MBP	
[°F]	20	130	95	115											
[°C]	-10	55	32	55	304,1	1039	261,7	1,34	4,58	1,15	226,8	1,67	7,35	cecomaf MBP	
[°F]	14	131	90	131											
[°C]	-10	45	20	45	347,1	1185	298,7	1,62	5,52	1,39	214,8	1,63	8,12	EN12900 MBP	
[°F]	14	113	68	113											
[°C]	-7	49	18	49	377,8	1290	325,1	1,62	5,53	1,39	233,4	1,69	9,33	ARI540 MBP	
[°F]	20	120	65	120											
[°C]	-10	45	32	45	360,1	1230	309,9	1,68	5,72	1,44	214,8	1,63	7,88	opt	
[°F]	14	113	90	113											
[°C]	-25	45	32	45	160,7	549	138,3	1,03	3,50	0,88	156,6	1,54	3,48	opt	
[°F]	-13	113	90	113											

Performance tables

R134a, 220V/50Hz, CSIR, fan 1,5m/s, VDE, UL, CCC, EAC, KC

	pe		Cooling capacity			COP	EER	P1	I	m	
	[°C]	[°F]	[W]	[Btu/h]	[kcal/h]	[W/W]	[Btu/Wh]	[kcal/Wh]	[W]	[A]	[kg/h]
[°C / °F]	-20	-4	215,3	735	185,3	1,22	4,18	1,05	176,0	1,56	4,68
cond. pressure	-15	5	281,3	961	242,0	1,44	4,92	1,24	195,3	1,59	6,13
pc= 45/113	-10	14	360,1	1230	309,9	1,68	5,72	1,44	214,8	1,63	7,88
return gas temp.	-5	23	453,4	1549	390,2	1,93	6,60	1,66	234,8	1,69	9,97
RGT= 32/90	0	32	562,9	1923	484,5	2,20	7,52	1,90	255,7	1,76	12,45
liquid temp	5	41	690,2	2357	594,0	2,49	8,49	2,14	277,7	1,84	15,37
Tliq= 45/113	15	59	1004,7	3431	864,7	3,08	10,51	2,65	326,6	2,04	22,76
[°C / °F]	-20	-4	179,3	612	154,3	0,99	3,37	0,85	181,5	1,57	4,30
cond. pressure	-15	5	236,2	807	203,3	1,16	3,95	1,00	204,1	1,61	5,69
pc= 55/131	-10	14	304,1	1039	261,7	1,34	4,58	1,15	226,8	1,67	7,35
return gas temp	-5	23	384,8	1314	331,1	1,54	5,26	1,32	249,9	1,74	9,35
RGT= 32/90	0	32	479,7	1638	412,8	1,75	5,99	1,51	273,7	1,82	11,73
liquid temp	5	41	590,5	2017	508,2	1,98	6,76	1,70	298,5	1,91	14,55
Tliq= 55/131	15	59	866,6	2960	745,8	2,46	8,40	2,12	352,5	2,14	21,77

Model

Designation	NL7.3MF	208-230V/60Hz	Conf. 3	Sales code:	105G6772
-------------	----------------	----------------------	----------------	-------------	-----------------

Configuration

Motorconfiguration	CSIR
Power supply (nominal)	208-230V/60Hz 1~
Refrigerant	R134a
Application	MBP
Voltage range	187-254V
Starting torque	HST
Approvals	VDE UL CCC EAC KC

Electrical accessories / wiring diagram

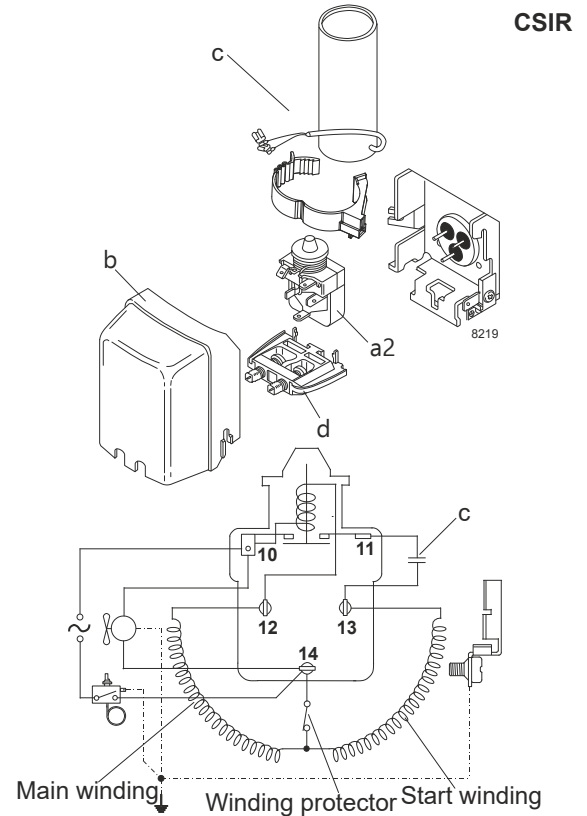

Ambient/ machine room temperatures minimum /maximum

Ambient temperature range:	10 - 43°C / 50 - 110°F
Machine room temperature range:	10 - 48°C / 50 - 119°F
Compressor cooling:	fan 1,5m/s

Operation Limits

Operation pressure range

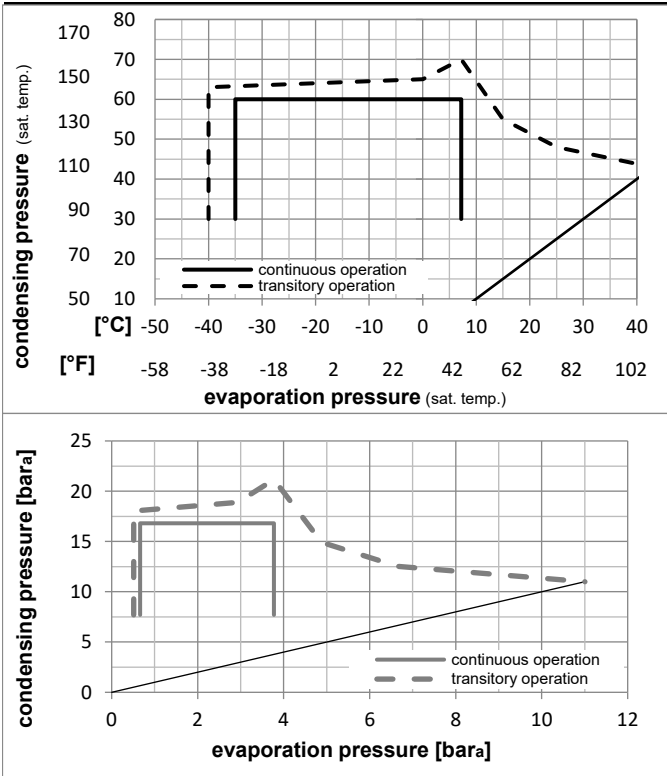

Components

a2	relay	117U6016
c	start capacitor (80µF)	117U5015
b	plastic cover	103N2011
d	cord relief	103N1010

Model

Designation **NL7.3MF** **208-230V/60Hz** Conf. 3 Sales code: **105G6772**

Optimization + standard conditions

R134a, 220V/60Hz, CSIR, fan 1,5m/s, VDE, UL, CCC, EAC, KC

		Evaporating pressure (saturation temperature)				Condensing pressure (saturation temperature)					Power consumption				
		Return gas temp.			Liquid temp.		Cooling capacity			COP	EER	Current consumption		Ref. mass flow	
		pe	pc	RGT	Tliq	[W]	[Btu/h]	[kcal/h]	[W/W]	[Btu/Wh]	[kcal/Wh]	P1	I	m	
[°C]	[°F]	[°C]	[°F]	[°C]	[°C]							[W]	[A]	[kg/h]	
[°C]	-7	54	35	46	471,3	1610	405,6	1,59	5,42	1,37	297,0	1,75	10,28	ASHRAE MBP	
[°F]	20	130	95	115											
[°C]	-10	55	32	55	363,0	1240	312,4	1,32	4,51	1,14	275,0	1,66	8,78	cecomaf MBP	
[°F]	14	131	90	131											
[°C]	-10	45	20	45	417,0	1424	358,9	1,60	5,47	1,38	260,6	1,61	9,76	EN12900 MBP	
[°F]	14	113	68	113											
[°C]	-7	49	18	49	453,6	1549	390,3	1,58	5,41	1,36	286,3	1,71	11,20	ARI540 MBP	
[°F]	20	120	65	120											
[°C]	-10	45	32	45	432,6	1478	372,3	1,66	5,67	1,43	260,6	1,61	9,47	opt	
[°F]	14	113	90	113											
[°C]	-25	45	32	45	200,2	684	172,3	1,13	3,88	0,98	176,4	1,32	4,34	opt	
[°F]	-13	113	90	113											

Performance tables

R134a, 220V/60Hz, CSIR, fan 1,5m/s, VDE, UL, CCC, EAC, KC

	pe		Cooling capacity			COP	EER	P1	I	m	
	[°C]	[°F]	[W]	[Btu/h]	[kcal/h]	[W/W]	[Btu/Wh]	[kcal/Wh]	[W]	[A]	[kg/h]
[°C / °F]	-35	-31	105,3	360	90,7	0,86	2,93	0,74	122,9	1,16	2,27
cond. pressure	-25	-13	200,2	684	172,3	1,13	3,88	0,98	176,4	1,32	4,34
pc= 45/113	-15	5	340,7	1164	293,2	1,47	5,01	1,26	232,2	1,50	7,43
return gas temp.	-10	14	432,6	1478	372,3	1,66	5,67	1,43	260,6	1,61	9,47
RGT= 32/90	-5	23	541,4	1849	465,9	1,87	6,40	1,61	289,1	1,72	11,91
liquid temp	0	32	668,9	2284	575,6	2,11	7,19	1,81	317,6	1,85	14,79
Tliq= 45/113	7,2	45	888,9	3036	765,0	2,48	8,47	2,14	358,3	2,04	19,86
[°C / °F]	-35	-31	73,1	250	62,9	0,67	2,27	0,57	109,8	1,11	1,74
cond. pressure	-25	-13	159,4	544	137,2	0,92	3,13	0,79	173,8	1,30	3,81
pc= 55/131	-15	5	282,8	966	243,4	1,17	4,01	1,01	240,8	1,53	6,81
return gas temp	-10	14	363,0	1240	312,4	1,32	4,51	1,14	275,0	1,66	8,78
RGT= 32/90	-5	23	458,0	1564	394,2	1,48	5,05	1,27	309,6	1,80	11,13
liquid temp	0	32	569,6	1945	490,2	1,65	5,65	1,42	344,3	1,94	13,93
Tliq= 55/131	7,2	45	763,1	2606	656,7	1,93	6,61	1,67	394,4	2,16	18,87

Model

Designation	NL7.3MF	220-240V/50Hz 1~ 208-230V/60Hz 1~	Sales code:	105G6772
-------------	----------------	-----------------------------------	-------------	-----------------

Compressor design

Oil type	Polyolester	Refrigerant(s)	R134a, R513A
Oil viscosity	32cST	Displacement	7,27cm ³ / 0,44cu.in
Oil quantity	268cm ³ / 9,1fl.oz	Compressors on pallet	80
Refr. charge - tech. limit	600g / 21,2oz		
Free gas volume comp.	2360cm ³ / 79,8fl.oz		
Weight	10kg / 22lbs		
Motor protection	1# internal		
Winding resistance main	8,3Ω (at 25°C)		
Winding resistance aux	11,8Ω (at 25°C)		
Max. winding temp.	125°C / 257°F		
Max. discharge temp.	130°C / 266°F		



General - Configurations with NL7.3MF

	Conf. 1	Conf. 2	Conf. 3	Conf. 4
Motorconfiguration	CSIR	CSIR	RSIR	RSIR
Power supply (nominal)	220-240V/50Hz	208-230V/60Hz	220-240V/50Hz	208-230V/60Hz
Number of phases	1	1	1	1
Voltage range	187-254V	187-253V	187-254V	187-253V
Approvals	VDE, UL, CCC	VDE, UL, CCC	VDE, UL, CCC	VDE, UL, CCC
Starting torque	HST	HST	LST	LST
Note	- / -			

Applications with NL7.3MF

	Conf. 1	Conf. 2	Conf. 3	Conf. 4
Refrigerant	R513A	R513A	R513A	R513A
Application	MBP	MBP	MBP	MBP
System cooling	fan 3m/s	fan 1,5m/s	fan 3m/s	fan 1,5m/s
Hot gas defrost	- / -	- / -	- / -	- / -
Long interval pull down	OK	OK	OK	OK

Electrical data - Configurations with NL7.3MF

	Conf. 1	Conf. 2	Conf. 3	Conf. 4
Starting device type	relay	relay	PTC	PTC
Run capacitor	- / -	- / -	- / -	- / -
Start capacitor	80μF	80μF	- / -	- / -
LRA (locked rotor amps / 4s)	10,7A	10,8A	10,2A	9,3A
RLA (rated load amps / 1s)	2,1A	1,8A	2,1A	1,8A
Cut in current	10,7A	10,8A	15,1A	14,1A

Model

Designation

NL7.3MF

220-240V/50Hz 1~ 208-230V/60Hz 1~

Sales code:

105G6772

Compressor dimensions

Housing	A Height	197mm / 7,76in
	B Height	191mm / 7,52in
	C Length shell	205mm / 8,07in
	D Length w. cover	254mm / 10in
	E Width	166mm / 6,54in

Connectors		Suction	Discharge	Process
		X	Y	Z
Diameter	[mm]	ø 8,11-8,29	ø 6,11-6,29	ø 6,11-6,29
	(i:inside, o:outside) [in]	ø 0,32-0,33	ø 0,24-0,25	ø 0,24-0,25
Material		copper	copper	copper
Horizontal angle	±2°	0°	0°	0°
Vertical angle	±2°	15°	35°	155°
Position l/h/w	[mm]	126/76/78	133/103/54	-107/94/72
	[in]	4,9/3/3,1	5,2/4/2,1	-4,2/3,7/2,8
Straight tube l.	[mm]	12	12	12
	[in]	0,5	0,5	0,5

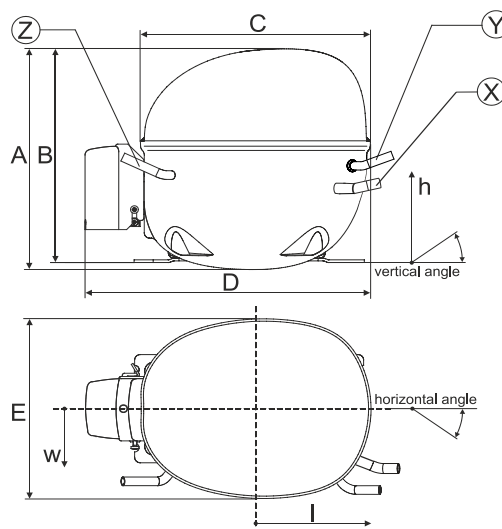

Compressor fixation

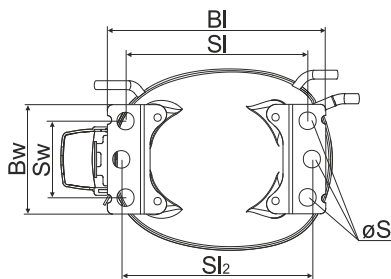

Baseplate	[mm]	[inch]
BI	204	8,03
Bw	100	3,94
Small holes		
	[mm]	[inch]
SI	170	6,7
Sw	70	2,76
Sl2	178	7
øS	ø 16	ø 0,63

Bolt joint

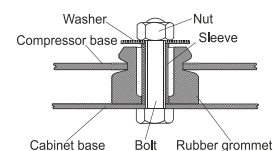

Snap-on

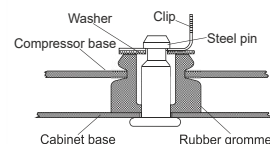

Mounting accessories	one comp.	multi pack
Bolt joint M6 ø16mm	118-1917	118-1918
Bolt joint ø1/4" ø16mm	118-1946	
Bolt joint ø1/4" ø19mm	118-1949	
Snap-on ø7,3 ø16mm	118-1947	118-1919

Application notes

LRA value on compressor label and datasheet may differ due to different test conditions for UL approval.

CSIR strongly recommended for 60Hz

F2 for 230-240V 50Hz nominal below -12°C evaporating temp

Provision for PE Grounding is located at the PE Stamp on the compressor

Model

Designation	NL7.3MF	220-240V/50Hz	Conf. 1	Sales code:	105G6772
-------------	----------------	----------------------	----------------	-------------	-----------------

Configuration

Motorconfiguration	CSIR
Power supply (nominal)	220-240V/50Hz 1~
Refrigerant	R513A
Application	MBP
Voltage range	187-254V
Starting torque	HST
Approvals	VDE
	UL
	CCC

Electrical accessories / wiring diagram

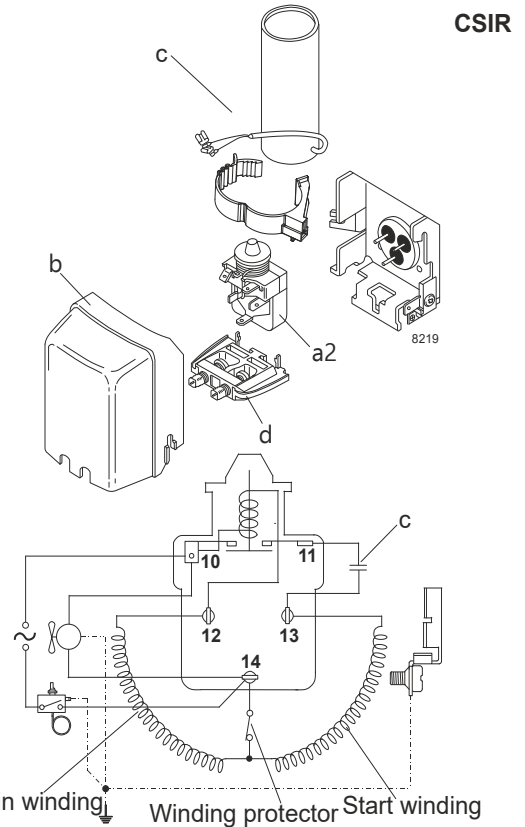

Ambient/ machine room temperatures minimum /maximum

Ambient temperature range:	10 - 43°C / 50 - 110°F
Machine room temperature range:	10 - 48°C / 50 - 119°F
Compressor cooling:	fan 1,5m/s

Operation Limits

Operation pressure range

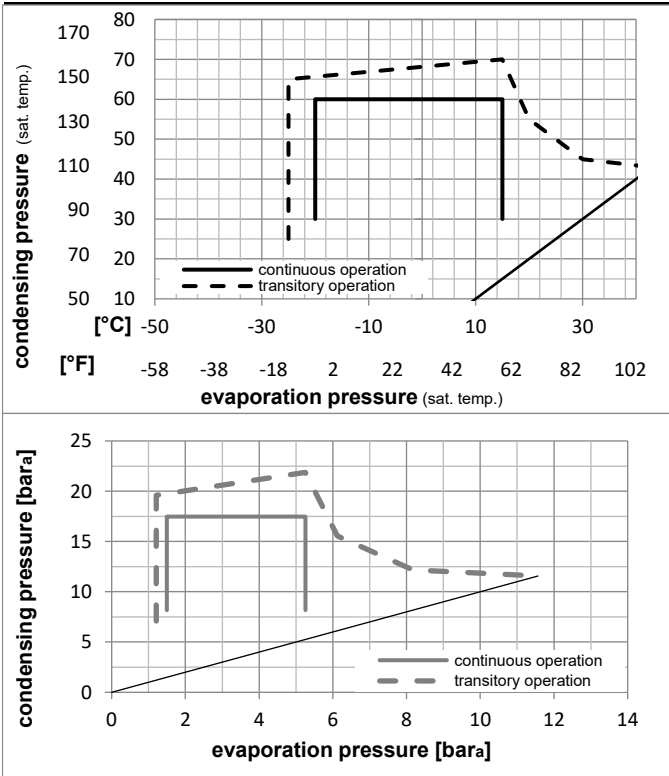

Components

a2	relay	117U6016
c	start capacitor (80μF)	117U5015
b	plastic cover	103N2011
d	cord relief	103N1010

Model

Designation **NL7.3MF** **220-240V/50Hz** Conf. 1 Sales code: **105G6772**

Optimization + standard conditions

R513A, 220V/50Hz, CSIR, fan 1,5m/s, VDE, UL, CCC

	Evaporating pressure (saturation temperature)				Condensing pressure (saturation temperature)			Return gas temp.	Liquid temp.	Cooling capacity	COP	EER	Power consumption			ASHRAE MBP
	pe	pc	RGT	Tliq	[W]	[Btu/h]	[kcal/h]						P1	I	Ref. mass flow	
[°C]	-7	54	35	46	415,5	1419	357,6	1,63	5,57	1,40	254,9	1,76	10,18			
[°F]	20	130	95	115												
	-10	55	32	55	316,3	1080	272,2	1,32	4,49	1,13	240,5	1,72	8,75	cecomaf MBP		
	-10	45	20	45	363,4	1241	312,8	1,60	5,47	1,38	227,0	1,68	9,63	EN12900 MBP		
	-10	45	32	45	380,0	1298	327,1	1,67	5,72	1,44	227,0	1,68	9,34	opt		
	-25	45	32	45	175,8	601	151,3	1,05	3,57	0,90	168,1	1,52	4,29	opt		

Performance tables

R513A, 220V/50Hz, CSIR, fan 1,5m/s, VDE, UL, CCC

	pe		Cooling capacity			COP	EER	P1	I	m	
	[°C]	[°F]	[W]	[Btu/h]	[kcal/h]	[W/W]	[Btu/Wh]	[kcal/Wh]	[W]	[A]	[kg/h]
[°C / °F]	-20	-4	232,3	793	199,9	1,24	4,22	1,06	187,9	1,58	5,67
cond. pressure	-15	5	299,8	1024	258,0	1,45	4,94	1,24	207,4	1,63	7,35
pc= 45/113	-10	14	380,0	1298	327,1	1,67	5,72	1,44	227,0	1,68	9,34
return gas temp.	-5	23	474,4	1620	408,3	1,92	6,56	1,65	247,0	1,74	11,71
RGT= 32/90	0	32	584,4	1996	503,0	2,18	7,46	1,88	267,7	1,79	14,50
liquid temp	5	41	711,7	2431	612,5	2,46	8,39	2,11	289,6	1,85	17,75
Tliq= 45/113	15	59	1023,9	3497	881,2	3,03	10,33	2,60	338,4	1,98	25,91
[°C / °F]	-20	-4	191,3	653	164,6	0,98	3,35	0,84	194,9	1,59	5,25
cond. pressure	-15	5	248,5	849	213,9	1,14	3,90	0,98	217,8	1,66	6,84
pc= 55/131	-10	14	316,3	1080	272,2	1,32	4,49	1,13	240,5	1,72	8,75
return gas temp	-5	23	396,3	1354	341,1	1,50	5,14	1,29	263,5	1,78	11,01
RGT= 32/90	0	32	490,0	1674	421,7	1,71	5,83	1,47	287,1	1,84	13,68
liquid temp	5	41	598,9	2045	515,4	1,92	6,56	1,65	311,7	1,91	16,83
Tliq= 55/131	15	59	868,3	2966	747,3	2,38	8,12	2,05	365,3	2,05	24,80

Model

Designation	NL7.3MF	208-230V/60Hz	Conf. 2	Sales code:	105G6772
-------------	----------------	----------------------	----------------	-------------	-----------------

Configuration

Motorconfiguration	CSIR
Power supply (nominal)	208-230V/60Hz 1~
Refrigerant	R513A
Application	MBP
Voltage range	187-253V
Starting torque	HST
Approvals	VDE UL CCC

Electrical accessories / wiring diagram

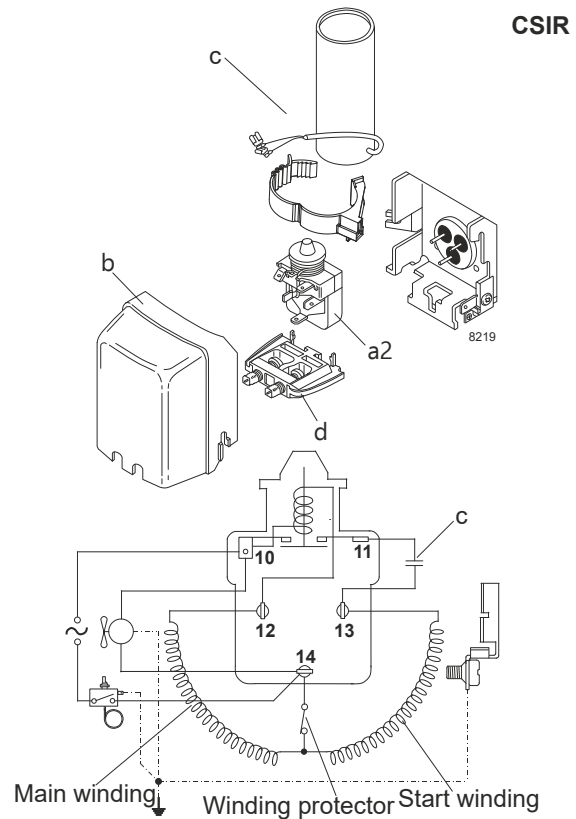

Ambient/ machine room temperatures minimum /maximum

Ambient temperature range:	10 - 43°C / 50 - 110°F
Machine room temperature range:	10 - 48°C / 50 - 119°F
Compressor cooling:	fan 1,5m/s

Operation Limits

Operation pressure range

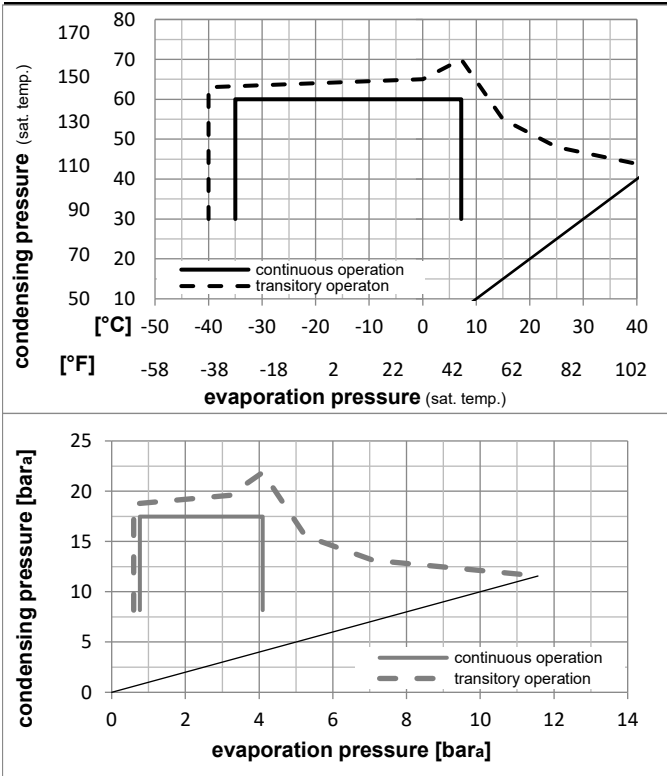

Components

a2	relay	117U6016
c	start capacitor (80µF)	117U5015
b	plastic cover	103N2011
d	cord relief	103N1010

Model

Designation **NL7.3MF** **208-230V/60Hz** Conf. 2 Sales code: **105G6772**

Optimization + standard conditions

R513A, 220V/60Hz, CSIR, fan 1,5m/s, VDE, UL, CCC

		Evaporating pressure (saturation temperature)				Condensing pressure (saturation temperature)					Power consumption				
		Return gas temp.			Liquid temp.		Cooling capacity			COP	EER	Current consumption		Ref. mass flow	
		pe	pc	RGT	Tliq	[W]	[Btu/h]	[kcal/h]	[W/W]	[Btu/Wh]	[kcal/Wh]	P1	I	m	
[°C]	[°F]	[°C]	[°F]	[°C]	[°C]							[W]	[A]	[kg/h]	
[°C]	-7	54	35	46	495,7	1693	426,6	1,57	5,36	1,35	315,6	1,84	12,14	ASHRAE MBP	
[°F]	20	130	95	115											
[°C]	-10	55	32	55	377,5	1289	324,9	1,29	4,39	1,11	293,6	1,75	10,44	cecomaf MBP	
[°F]	14	131	90	131											
[°C]	-10	45	20	45	436,6	1491	375,7	1,57	5,38	1,35	277,3	1,69	11,57	EN12900 MBP	
[°F]	14	113	68	113											
[°C]	-7	49	18	49	468,7	1601	403,4	1,54	5,27	1,33	303,8	1,79	13,21	ARI540 MBP	
[°F]	20	120	65	120											
[°C]	-10	45	32	45	456,5	1559	392,9	1,65	5,62	1,42	277,3	1,69	11,22	opt	
[°F]	14	113	90	113											
[°C]	-25	45	32	45	219,1	748	188,6	1,14	3,90	0,98	191,7	1,35	5,34	opt	
[°F]	-13	113	90	113											

Performance tables

R513A, 220V/60Hz, CSIR, fan 1,5m/s, VDE, UL, CCC

	pe		Cooling capacity			COP	EER	P1			I	m
	[°C]	[°F]	[W]	[Btu/h]	[kcal/h]	[W/W]	[Btu/Wh]	[kcal/Wh]	[W]	[A]	[kg/h]	
[°C / °F]	-35	-31	120,6	412	103,8	0,88	3,02	0,76	136,3	1,14	2,93	
cond. pressure	-25	-13	219,1	748	188,6	1,14	3,90	0,98	191,7	1,35	5,34	
pc= 45/113	-15	5	363,2	1240	312,6	1,46	4,99	1,26	248,6	1,58	8,90	
return gas temp.	-10	14	456,5	1559	392,9	1,65	5,62	1,42	277,3	1,69	11,22	
RGT= 32/90	-5	23	566,3	1934	487,4	1,85	6,32	1,59	306,0	1,80	13,98	
liquid temp	0	32	694,2	2371	597,5	2,08	7,09	1,79	334,4	1,91	17,22	
Tliq= 45/113	7,2	45	913,8	3121	786,4	2,44	8,33	2,10	374,8	2,07	22,86	
[°C / °F]	-35	-31	84,9	290	73,1	0,69	2,34	0,59	123,7	1,09	2,32	
cond. pressure	-25	-13	173,1	591	149,0	0,91	3,11	0,78	190,2	1,35	4,74	
pc= 55/131	-15	5	297,5	1016	256,0	1,15	3,93	0,99	258,8	1,61	8,19	
return gas temp	-10	14	377,5	1289	324,9	1,29	4,39	1,11	293,6	1,75	10,44	
RGT= 32/90	-5	23	471,7	1611	406,0	1,44	4,90	1,24	328,5	1,89	13,10	
liquid temp	0	32	581,7	1987	500,6	1,60	5,47	1,38	363,3	2,02	16,25	
Tliq= 55/131	7,2	45	771,4	2634	663,9	1,87	6,38	1,61	413,1	2,22	21,75	

Model

Designation	NL7.3MF	220-240V/50Hz	Conf. 3	Sales code:	105G6772
-------------	----------------	----------------------	----------------	-------------	-----------------

Configuration

Motorconfiguration	RSIR
Power supply (nominal)	220-240V/50Hz 1~
Refrigerant	R513A
Application	MBP
Voltage range	187-254V
Starting torque	LST
Approvals	VDE UL CCC

Electrical accessories / wiring diagram

RSIR

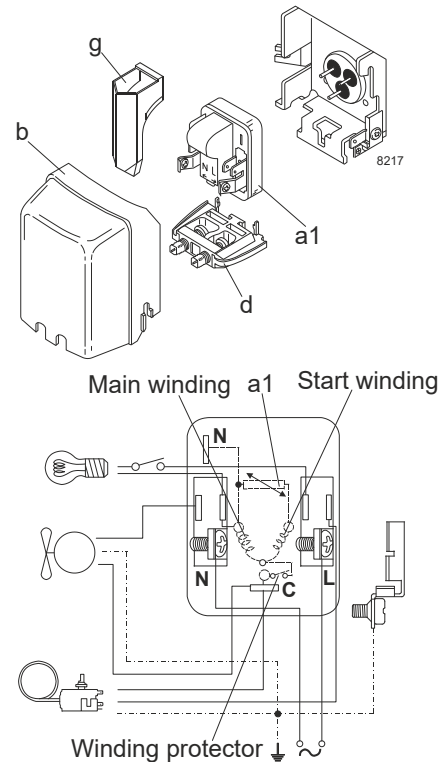

Ambient/ machine room temperatures minimum /maximum

Ambient temperature range:	10 - 43°C / 50 - 110°F
Machine room temperature range:	10 - 48°C / 50 - 119°F
Compressor cooling:	fan 1,5m/s

Operation Limits

Operation pressure range

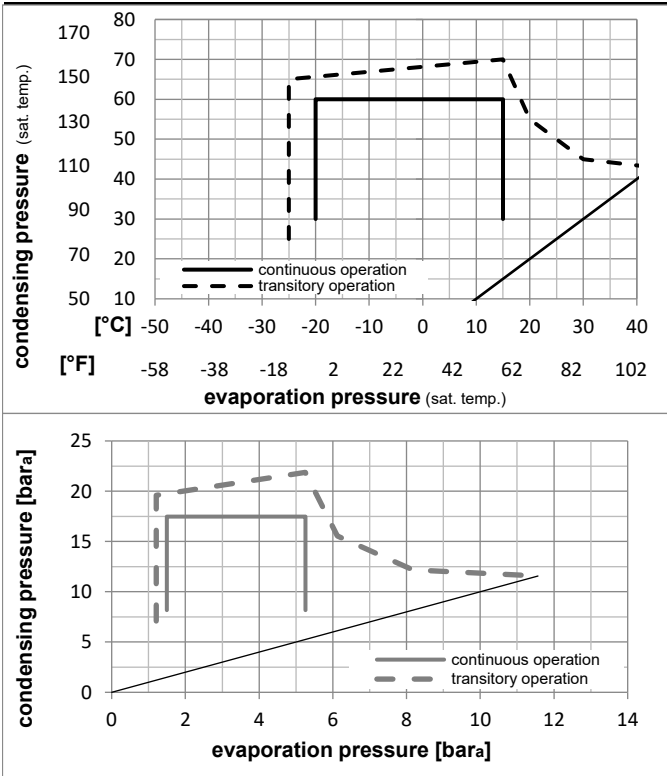

Components

a1	PTC starter (220V, 25Ohm, 4.8mm)	103N0018
b	plastic cover	103N2011
d	cord relief	103N1010
g	protection screen for PTC	103N0476

Alternative components

a1	PTC starter (220V, 25Ohm, 6.3mm)	103N0011
b	plastic cover	103N2010
d	cord relief	103N1010
g	protection screen for PTC	103N0476

Model

Designation **NL7.3MF** **220-240V/50Hz** Conf. 3 Sales code: **105G6772**

Optimization + standard conditions

R513A, 220V/50Hz, RSIR, fan 1,5m/s, VDE, UL, CCC

		Evaporating pressure (saturation temperature)				Condensing pressure (saturation temperature)						Power consumption			
		Return gas temp.		Liquid temp.		Cooling capacity		COP	EER		P1	I	Ref. mass flow		
		pe	pc	RGT	Tliq	[W]	[Btu/h]	[kcal/h]	[W/W]	[Btu/Wh]	[kcal/Wh]	[W]	[A]	[kg/h]	
[°C]	-7	54	35	46	415,5	1419	357,6	1,63	5,57	1,40	254,9	1,76	10,18	ASHRAE MBP	
[°F]	20	130	95	115											
[°C]	-10	55	32	55	316,3	1080	272,2	1,32	4,49	1,13	240,5	1,72	8,75	cecomaf MBP	
[°F]	14	131	90	131											
[°C]	-10	45	20	45	363,4	1241	312,8	1,60	5,47	1,38	227,0	1,68	9,63	EN12900 MBP	
[°F]	14	113	68	113											
[°C]	-7	49	18	49	390,5	1334	336,1	1,59	5,42	1,37	246,1	1,73	11,00	ARI540 MBP	
[°F]	20	120	65	120											
[°C]	-10	45	32	45	380,0	1298	327,1	1,67	5,72	1,44	227,0	1,68	9,34	opt	
[°F]	14	113	90	113											
[°C]	-25	45	32	45	175,8	601	151,3	1,05	3,57	0,90	168,1	1,52	4,29	opt	
[°F]	-13	113	90	113											

Performance tables

R513A, 220V/50Hz, RSIR, fan 1,5m/s, VDE, UL, CCC

	pe		Cooling capacity			COP	EER	P1			I	m
	[°C]	[°F]	[W]	[Btu/h]	[kcal/h]	[W/W]	[Btu/Wh]	[kcal/Wh]	[W]	[A]	[kg/h]	
[°C / °F]	-20	-4	232,3	793	199,9	1,24	4,22	1,06	187,9	1,58	5,67	
cond. pressure	-15	5	299,8	1024	258,0	1,45	4,94	1,24	207,4	1,63	7,35	
pc= 45/113	-10	14	380,0	1298	327,1	1,67	5,72	1,44	227,0	1,68	9,34	
return gas temp.	-5	23	474,4	1620	408,3	1,92	6,56	1,65	247,0	1,74	11,71	
RGT= 32/90	0	32	584,4	1996	503,0	2,18	7,46	1,88	267,7	1,79	14,50	
liquid temp	5	41	711,7	2431	612,5	2,46	8,39	2,11	289,6	1,85	17,75	
Tliq= 45/113	15	59	1023,9	3497	881,2	3,03	10,33	2,60	338,4	1,98	25,91	
[°C / °F]	-20	-4	191,3	653	164,6	0,98	3,35	0,84	194,9	1,59	5,25	
cond. pressure	-15	5	248,5	849	213,9	1,14	3,90	0,98	217,8	1,66	6,84	
pc= 55/131	-10	14	316,3	1080	272,2	1,32	4,49	1,13	240,5	1,72	8,75	
return gas temp	-5	23	396,3	1354	341,1	1,50	5,14	1,29	263,5	1,78	11,01	
RGT= 32/90	0	32	490,0	1674	421,7	1,71	5,83	1,47	287,1	1,84	13,68	
liquid temp	5	41	598,9	2045	515,4	1,92	6,56	1,65	311,7	1,91	16,83	
Tliq= 55/131	15	59	868,3	2966	747,3	2,38	8,12	2,05	365,3	2,05	24,80	

Model

Designation	NL7.3MF	208-230V/60Hz	Conf. 4	Sales code:	105G6772
-------------	----------------	----------------------	----------------	-------------	-----------------

Configuration

Motorconfiguration	RSIR
Power supply (nominal)	208-230V/60Hz 1~
Refrigerant	R513A
Application	MBP
Voltage range	187-253V
Starting torque	LST
Approvals	VDE UL CCC

Electrical accessories / wiring diagram

RSIR

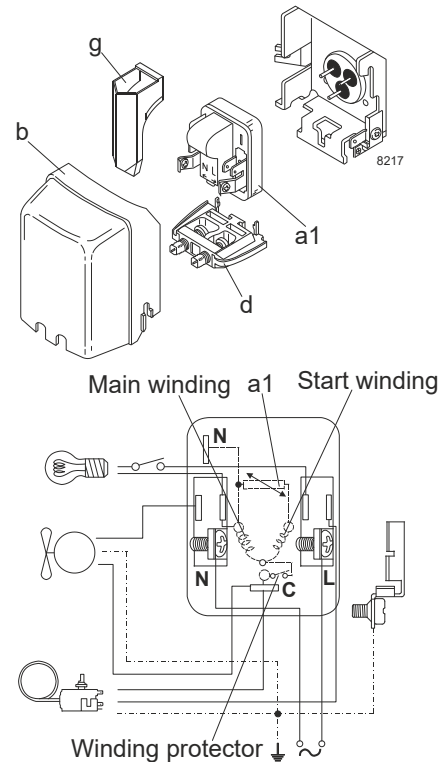

Ambient/ machine room temperatures minimum /maximum

Ambient temperature range:	10 - 43°C / 50 - 110°F
Machine room temperature range:	10 - 48°C / 50 - 119°F
Compressor cooling:	fan 1,5m/s

Operation Limits

Operation pressure range

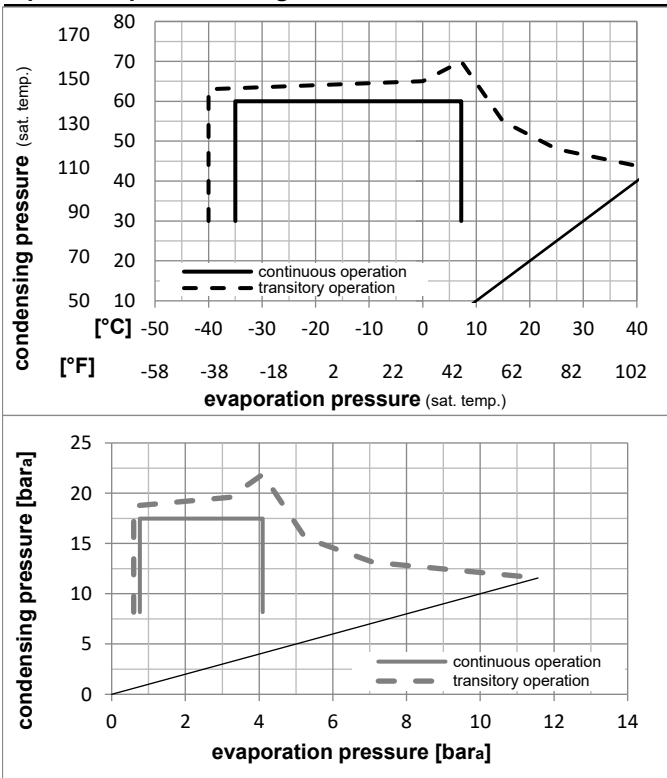

Components

a1	PTC starter (220V, 250hm, 4.8mm)	103N0018
b	plastic cover	103N2011
d	cord relief	103N1010
g	protection screen for PTC	103N0476

Alternative components

a1	PTC starter (220V, 250hm, 6.3mm)	103N0011
b	plastic cover	103N2010
d	cord relief	103N1010
g	protection screen for PTC	103N0476

Model

Designation **NL7.3MF** **208-230V/60Hz** Conf. 4 Sales code: **105G6772**

Optimization + standard conditions

R513A, 220V/60Hz, RSIR, fan 1,5m/s, VDE, UL, CCC

		Evaporating pressure (saturation temperature)				Condensing pressure (saturation temperature)					Power consumption				
		Return gas temp.			Liquid temp.		Cooling capacity			COP	EER	Current consumption		Ref. mass flow	
		pe	pc	RGT	Tliq	[W]	[Btu/h]	[kcal/h]	[W/W]	[Btu/Wh]	[kcal/Wh]	P1	I	m	
[°C]	[°F]	[°C]	[°F]	[°C]	[°C]							[W]	[A]	[kg/h]	
[°C]	-7	54	35	46	495,7	1693	426,6	1,57	5,36	1,35	315,6	1,84	12,14	ASHRAE MBP	
[°F]	20	130	95	115											
[°C]	-10	55	32	55	377,5	1289	324,9	1,29	4,39	1,11	293,6	1,75	10,44	cecomaf MBP	
[°F]	14	131	90	131											
[°C]	-10	45	20	45	436,6	1491	375,7	1,57	5,38	1,35	277,3	1,69	11,57	EN12900 MBP	
[°F]	14	113	68	113											
[°C]	-7	49	18	49	468,7	1601	403,4	1,54	5,27	1,33	303,8	1,79	13,21	ARI540 MBP	
[°F]	20	120	65	120											
[°C]	-10	45	32	45	456,5	1559	392,9	1,65	5,62	1,42	277,3	1,69	11,22	opt	
[°F]	14	113	90	113											
[°C]	-25	45	32	45	219,1	748	188,6	1,14	3,90	0,98	191,7	1,35	5,34	opt	
[°F]	-13	113	90	113											

Performance tables

R513A, 220V/60Hz, RSIR, fan 1,5m/s, VDE, UL, CCC

	pe		Cooling capacity			COP	EER	P1			I	m
	[°C]	[°F]	[W]	[Btu/h]	[kcal/h]	[W/W]	[Btu/Wh]	[kcal/Wh]	[W]	[A]	[kg/h]	
[°C / °F]	-35	-31	120,6	412	103,8	0,88	3,02	0,76	136,3	1,14	2,93	
cond. pressure	-25	-13	219,1	748	188,6	1,14	3,90	0,98	191,7	1,35	5,34	
pc= 45/113	-15	5	363,2	1240	312,6	1,46	4,99	1,26	248,6	1,58	8,90	
return gas temp.	-10	14	456,5	1559	392,9	1,65	5,62	1,42	277,3	1,69	11,22	
RGT= 32/90	-5	23	566,3	1934	487,4	1,85	6,32	1,59	306,0	1,80	13,98	
liquid temp	0	32	694,2	2371	597,5	2,08	7,09	1,79	334,4	1,91	17,22	
Tliq= 45/113	7,2	45	913,8	3121	786,4	2,44	8,33	2,10	374,8	2,07	22,86	
[°C / °F]	-35	-31	84,9	290	73,1	0,69	2,34	0,59	123,7	1,09	2,32	
cond. pressure	-25	-13	173,1	591	149,0	0,91	3,11	0,78	190,2	1,35	4,74	
pc= 55/131	-15	5	297,5	1016	256,0	1,15	3,93	0,99	258,8	1,61	8,19	
return gas temp	-10	14	377,5	1289	324,9	1,29	4,39	1,11	293,6	1,75	10,44	
RGT= 32/90	-5	23	471,7	1611	406,0	1,44	4,90	1,24	328,5	1,89	13,10	
liquid temp	0	32	581,7	1987	500,6	1,60	5,47	1,38	363,3	2,02	16,25	
Tliq= 55/131	7,2	45	771,4	2634	663,9	1,87	6,38	1,61	413,1	2,22	21,75	