

Model

Designation	NL7FT	220-240V/50Hz 1~	Sales code:	105G6718
-------------	--------------	-------------------------	-------------	-----------------

Compressor design

Oil type	Polyolester	Refrigerant(s)	R134a
Oil viscosity	32cST	Displacement	7,27cm ³ / 0,44cu.in
Oil quantity	268cm ³ / 9,1fl.oz	Compressors on pallet	80
Refr. charge - tech. limit	400g / 14,1oz		
Free gas volume comp.	2360cm ³ / 79,8fl.oz		
Weight	10kg / 22lbs		
Motor protection	1# internal		
Winding resistance main	10,7Ω (at 25°C)		
Winding resistance aux	13Ω (at 25°C)		
Max. winding temp.	125°C / 257°F		
Max. discharge temp.	130°C / 266°F		



General - Configurations with NL7FT

	Conf. 1	Conf. 2
Motorconfiguration	CSIR	RSIR
Power supply (nominal)	220-240V/50Hz	220-240V/50Hz
Number of phases	1	1
Voltage range	187-254V	187-254V
Approvals	CCC, EAC, VDE	CCC, EAC, VDE
Starting torque	HST	LST
Note	- / -	

Applications with NL7FT

	Conf. 1	Conf. 2
Refrigerant	R134a	R134a
Application	LBP	LBP
System cooling	static	static
Hot gas defrost	- / -	- / -
Long interval pull down	- / -	- / -

Electrical data - Configurations with NL7FT

	Conf. 1	Conf. 2
Starting device type	relay	PTC
Run capacitor	- / -	- / -
Start capacitor	80μF	- / -
LRA (locked rotor amps / 4s)	8,7A	7,9A
RLA (rated load amps / 1s)		
Cut in current	10,9A	7,9A

Model

Designation	NL7FT	220-240V/50Hz 1~	Sales code:	105G6718
-------------	--------------	-------------------------	-------------	-----------------

Compressor dimensions

Housing	A Height	197mm / 7,76in
	B Height	191mm / 7,52in
	C Length shell	205mm / 8,07in
	D Length w. cover	254mm / 10in
	E Width	166mm / 6,54in

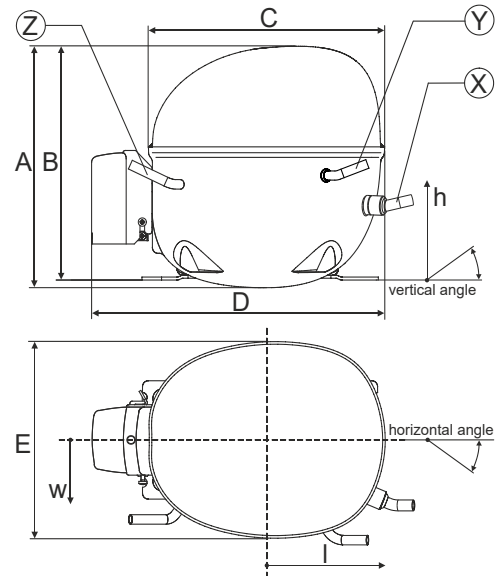

Connectors		Suction	Discharge	Process
		X	Y	Z
Diameter	[mm]	øi 6,11-6,29	øi 5,12-5,22	øi 6,11-6,29
(i:inside, o:outside)	[in]	øi 0,24-0,25	øi 0,2-0,21	øi 0,24-0,25
Material		copper	copper	copper
Horizontal angle	±2°	0°	0°	0°
Vertical angle	±2°	15°	35°	155°
Position l/h/w	[mm]	126/76/78	133/103/54	-107/94/72
	[in]	4,9/3/3,1	5,2/4/2,1	-4,2/3,7/2,8
Straight tube l.	[mm]	12	12	12
	[in]	0,5	0,5	0,5

Compressor fixation

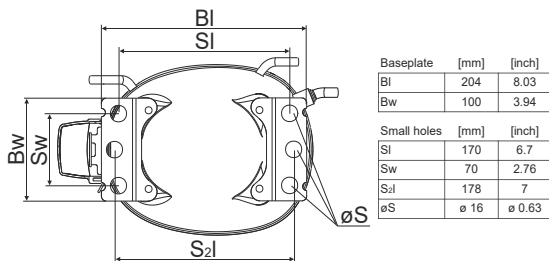

Bolt joint

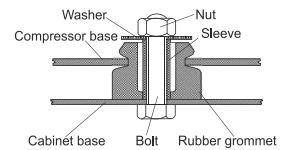

Snap-on

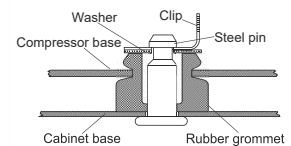

Mounting accessories	one comp.	multi pack
Bolt joint M6 ø16mm	118-1917	118-1918
Bolt joint ø1/4" ø16mm	118-1946	
Bolt joint ø1/4" ø19mm	118-1949	
Snap-on ø7,3 ø16mm	118-1947	118-1919

Model

Designation	NL7FT	220-240V/50Hz	Conf. 1	Sales code:	105G6718
-------------	--------------	----------------------	----------------	-------------	-----------------

Configuration

Motorconfiguration	CSIR
Power supply (nominal)	220-240V/50Hz 1~
Refrigerant	R134a
Application	LBP
Voltage range	187-254V
Starting torque	HST
Approvals	CCC
	EAC
	VDE

Electrical accessories / wiring diagram

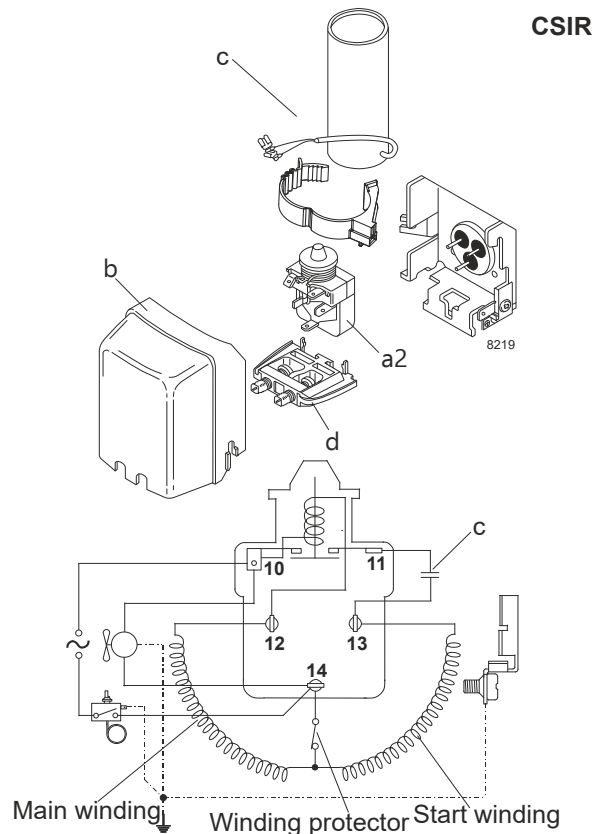

Ambient temperatures / system cooling

Ambient temperature min.:	10°C / 50°F
Ambient temperature max.:	43°C / 110°F

System cooling (n/a: outside limits)			
T ambient	LBP	MBP	HBP
32°C / 90°F	static	n/a	n/a
38°C / 100°F	static	n/a	n/a
43°C / 110°F	fan 1,5m/s	n/a	n/a

Operation pressure range

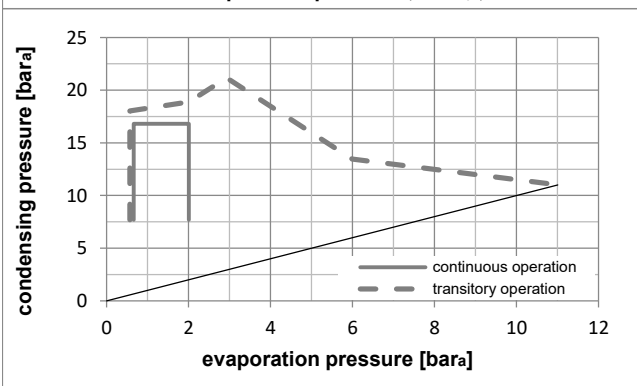
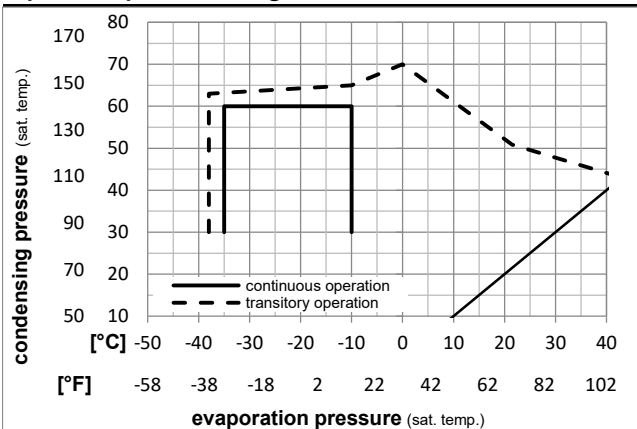

Components

a2	current relay	117U6001
c	start capacitor (80µF)	117U5015
b	plastic cover	103N2010
d	cord relief	103N1010

Alternative components

b	plastic cover	103N2011
---	---------------	----------

Model

Designation	NL7FT	220-240V/50Hz	Conf. 1	Sales code:	105G6718
-------------	--------------	----------------------	----------------	-------------	-----------------

Optimization + standard conditions

R134a, 220V/50Hz, CSIR, static, CCC, EAC, VDE

		Evaporating pressure (saturation temperature)				Condensing pressure (saturation temperature)					Power consumption				
											Current consumption				
														Ref. mass flow	
											P1	I	m		
		pe	pc	RGT	Tliq	[W]	[Btu/h]	[kcal/h]	COP	EER	[W]	[A]	[kg/h]		
[°C]	[°F]														
-23,3	-10	54,4	32,2	32,2	185,6	634	159,7	1,22	4,16	1,05	152,5	0,96	3,60	ASHRAE LBP	
-25	-13	55	32	55	136,2	465	117,2	0,94	3,21	0,81	144,7	0,94	3,26	cecomaf LBP	
-35	-31	40	20	40	93,9	321	80,9	0,88	3,01	0,76	106,6	0,84	2,06	EN12900 LBP	
-23,3	-10	48,9	4,44	48,9	153,6	525	132,2	1,01	3,46	0,87	151,7	0,95	4,06	ARI540 LBP	
-23,3	-10	40,6	32,2	32,2	207,5	709	178,6	1,41	4,83	1,22	146,7	0,94	4,03	AHAM LBP	
-35	-31	45	32	45	88,8	303	76,5	0,82	2,81	0,71	108,0	0,84	1,92	opt	

Performance tables

R134a, 220V/50Hz, CSIR, static, CCC, EAC, VDE

[°C / °F]	pe	Cooling capacity			COP	EER	P1	I	m		
	[°C]	[°F]	[W]	[Btu/h]	[kcal/h]	[W/W]	[Btu/Wh]	[kcal/Wh]	[W]	[A]	[kg/h]
-35	-31	88,8	303	76,5	0,82	2,81	0,71	108,0	0,84	1,92	
cond. pressure	-30	-22	122,4	418	105,4	0,99	3,38	0,85	123,6	0,87	2,65
pc= 45/113	-25	-13	164,2	561	141,3	1,15	3,93	0,99	142,7	0,92	3,56
return gas temp.	-23,3	-10	180,4	616	155,3	1,21	4,12	1,04	149,7	0,94	3,91
RGT= 32/90	-20	-4	215,3	735	185,3	1,31	4,49	1,13	163,9	0,99	4,68
liquid temp	-15	5	277,2	947	238,5	1,49	5,08	1,28	186,2	1,07	6,04
Tliq= 45/113	-10	14	350,9	1198	302,0	1,68	5,75	1,45	208,4	1,16	7,68
-35	-31	71,0	242	61,1	0,66	2,25	0,57	107,7	0,86	1,69	
cond. pressure	-30	-22	100,1	342	86,1	0,81	2,75	0,69	124,1	0,88	2,39
pc= 55/131	-25	-13	136,2	465	117,2	0,94	3,21	0,81	144,7	0,94	3,26
return gas temp	-23,3	-10	150,3	513	129,4	0,99	3,37	0,85	152,4	0,96	3,60
RGT= 32/90	-20	-4	180,6	617	155,5	1,07	3,67	0,92	168,3	1,01	4,33
liquid temp	-15	5	234,6	801	201,9	1,21	4,14	1,04	193,6	1,11	5,65
Tliq= 55/131	-10	14	299,4	1022	257,6	1,36	4,66	1,17	219,6	1,21	7,24

Model

Designation	NL7FT	220-240V/50Hz	Conf. 2	Sales code:	105G6718
-------------	--------------	----------------------	----------------	-------------	-----------------

Configuration

Motorconfiguration	RSIR
Power supply (nominal)	220-240V/50Hz 1~
Refrigerant	R134a
Application	LBP
Voltage range	187-254V
Starting torque	LST
Approvals	CCC
	EAC
	VDE

Electrical accessories / wiring diagram

RSIR

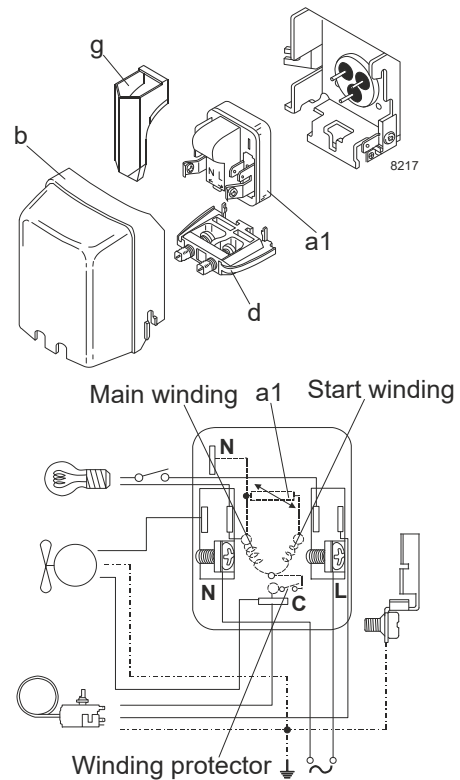

Ambient temperatures / system cooling

Ambient temperature min.:	10°C / 50°F
Ambient temperature max.:	43°C / 110°F

System cooling (n/a: outside limits)			
T ambient	LBP	MBP	HBP
32°C / 90°F	static	n/a	n/a
38°C / 100°F	static	n/a	n/a
43°C / 110°F	fan 1,5m/s	n/a	n/a

Operation pressure range

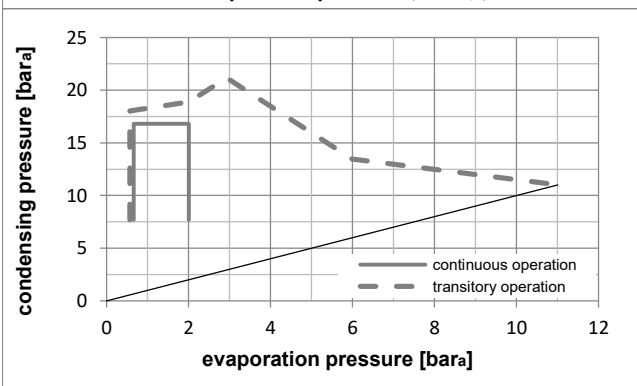
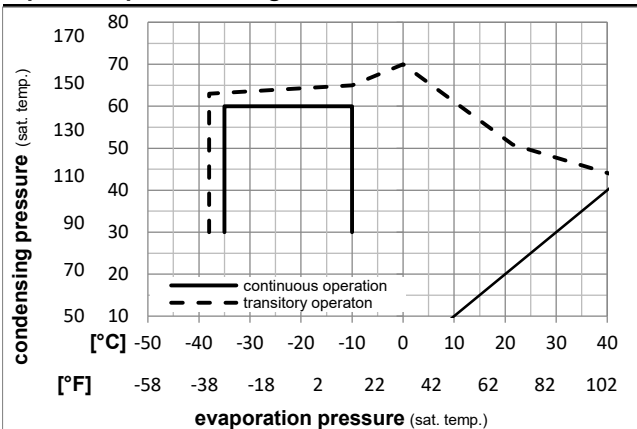

Components

a1	PTC starter (220V, 250hm, 4.8mm)	103N0018
b	plastic cover	103N2010
d	cord relief	103N1010
g	protection screen for PTC	103N0476

Alternative components

a1	PTC starter (220V, 250hm, 6.3mm)	103N0011
b	plastic cover	103N2011
d	cord relief	103N1010
g	protection screen for PTC	103N0476

Model

Designation **NL7FT 220-240V/50Hz** Conf. 2 Sales code: **105G6718**

Optimization + standard conditions

R134a, 220V/50Hz, RSIR, static, CCC, EAC, VDE

Evaporating pressure (saturation temperature)					Condensing pressure (saturation temperature)						Power consumption				ASHRAE LBP
Return gas temp.					Liquid temp.						Current consumption			Ref. mass flow	
Cooling capacity					COP		EER		P1	I	m				
pe	pc	RGT	Tliq	[W]	[Btu/h]	[kcal/h]	[W/W]	[Btu/Wh]	[kcal/Wh]	[W]	[A]	[kg/h]			
[°C]	-23	54,4	32,2	32,2	185,6	634	159,7	1,22	4,16	1,05	152,5	0,96	3,60	ASHRAE LBP	
[°F]	-10	130	90	90											
[°C]	-25	55	32	55	136,2	465	117,2	0,94	3,21	0,81	144,7	0,94	3,26	cecomaf LBP	
[°F]	-13	131	89,6	131											
[°C]	-35	40	20	40	93,9	321	80,9	0,88	3,01	0,76	106,6	0,84	2,06	EN12900 LBP	
[°F]	-31	104	68	104											
[°C]	-23	48,9	4,44	48,9	153,6	525	132,2	1,01	3,46	0,87	151,7	0,95	4,06	ARI540 LBP	
[°F]	-10	120	40	120											
[°C]	-23	40,6	32,2	32,2	207,5	709	178,6	1,41	4,83	1,22	146,7	0,94	4,03	AHAM LBP	
[°F]	-10	105	90	90											
[°C]	-35	45	32	45	88,8	303	76,5	0,82	2,81	0,71	108,0	0,84	1,92	opt	
[°F]	-31	113	89,6	113											

Performance tables

R134a, 220V/50Hz, RSIR, static, CCC, EAC, VDE

	pe	Cooling capacity			COP		EER		P1	I	m
	[°C]	[°F]	[W]	[Btu/h]	[kcal/h]	[W/W]	[Btu/Wh]	[kcal/Wh]	[W]	[A]	[kg/h]
[°C / °F]	-35	-31	88,8	303	76,5	0,82	2,81	0,71	108,0	0,84	1,92
cond. pressure	-30	-22	122,4	418	105,4	0,99	3,38	0,85	123,6	0,87	2,65
pc= 45/113	-25	-13	164,2	561	141,3	1,15	3,93	0,99	142,7	0,92	3,56
return gas temp.	-23	-10	180,4	616	155,3	1,21	4,12	1,04	149,7	0,94	3,91
RGT= 32/90	-20	-4	215,3	735	185,3	1,31	4,49	1,13	163,9	0,99	4,68
liquid temp	-15	5	277,2	947	238,5	1,49	5,08	1,28	186,2	1,07	6,04
Tliq= 45/113	-10	14	350,9	1198	302,0	1,68	5,75	1,45	208,4	1,16	7,68
[°C / °F]	-35	-31	71,0	242	61,1	0,66	2,25	0,57	107,7	0,86	1,69
cond. pressure	-30	-22	100,1	342	86,1	0,81	2,75	0,69	124,1	0,88	2,39
pc= 55/131	-25	-13	136,2	465	117,2	0,94	3,21	0,81	144,7	0,94	3,26
return gas temp	-23	-10	150,3	513	129,4	0,99	3,37	0,85	152,4	0,96	3,60
RGT= 32/90	-20	-4	180,6	617	155,5	1,07	3,67	0,92	168,3	1,01	4,33
liquid temp	-15	5	234,6	801	201,9	1,21	4,14	1,04	193,6	1,11	5,65
Tliq= 55/131	-10	14	299,4	1022	257,6	1,36	4,66	1,17	219,6	1,21	7,24