

Model

Designation	NL9CLX	220-240V/50Hz 1~	Sales code:	105F3802
-------------	---------------	-------------------------	-------------	-----------------

Compressor design

Oil type	Polyolester	Refrigerant(s)	R404A, R507
Oil viscosity	32cST	Displacement	8,35cm ³ / 0,51cu.in
Oil quantity	298cm ³ / 10,1fl.oz	Compressors on pallet	80
Refr. charge - tech. limit	600g / 21,2oz		
Free gas volume comp.	2310cm ³ / 78,1fl.oz		
Weight	10,4kg / 22,9lbs		
Motor protection	1# internal		
Winding resistance main	6,1Ω (at 25°C)		
Winding resistance aux	16Ω (at 25°C)		
Max. winding temp.	125°C / 257°F		
Max. discharge temp.	130°C / 266°F		



General - Configurations with NL9CLX

	Conf. 1
Motorconfiguration	CSIR
Power supply (nominal)	220-240V/50Hz
Number of phases	1
Voltage range	198-254V
Approvals	CCC
Starting torque	HST
Note	- / -

Applications with NL9CLX

	Conf. 1
Refrigerant	R404A
Application	LBP
System cooling	fan 3m/s
Hot gas defrost	- / -
Long interval pull down	- / -

Electrical data - Configurations with NL9CLX

	Conf. 1
Starting device type	relay
Run capacitor	- / -
Start capacitor	80μF
LRA (locked rotor amps / 4s)	13,7A
RLA (rated load amps / 1s)	2,5A
Cut in current	13,7A

Model

Designation	NL9CLX	220-240V/50Hz 1~	Sales code:	105F3802
-------------	---------------	------------------	-------------	-----------------

Compressor dimensions

Housing	A Height	203mm / 7,99in
	B Height	197mm / 7,76in
	C Length shell	205mm / 8,07in
	D Length w. cover	254mm / 10in
	E Width	166mm / 6,54in

Connectors		Suction	Discharge	Process
		X	Y	Z
Diameter	[mm]	øi 8,11-8,29	øi 6,11-6,29	øi 6,11-6,29
	(i:inside, o:outside) [in]	øi 0,32-0,33	øi 0,24-0,25	øi 0,24-0,25
Material		copper	copper	copper
Horizontal angle	±2°	0°	0°	0°
Vertical angle	±2°	15°	35°	155°
Position l/h/w	[mm]	126/76/78	133/103/54	-107/94/72
	[in]	4,9/3/3,1	5,2/4/2,1	-4,2/3,7/2,8
Straight tube l.	[mm]	12	12	12
	[in]	0,5	0,5	0,5

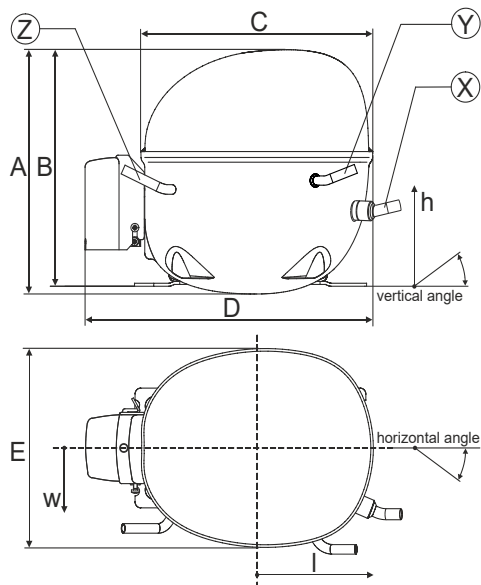

Compressor fixation

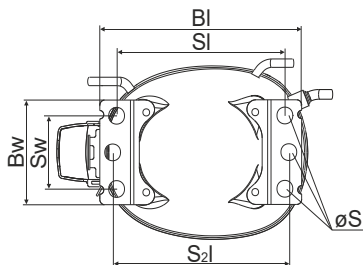

Baseplate	[mm]	[inch]
BI	204	8.03
Bw	100	3.94

Small holes	[mm]	[inch]
SI	170	6.7
Sw	70	2.76
S2l	178	7
øS	ø 16	ø 0.63

Bolt joint

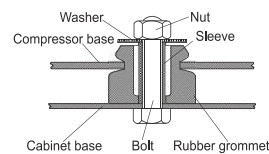

Snap-on

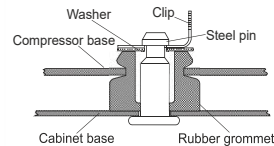

Mounting accessories	one comp.	multi pack
Bolt joint M6 ø16mm	118-1917	118-1918
Bolt joint ø1/4" ø16mm	118-1946	
Bolt joint ø1/4" ø19mm	118-1949	
Snap-on ø7,3 ø16mm	118-1947	118-1919

Model

Designation	NL9CLX	220-240V/50Hz	Conf. 1	Sales code:	105F3802
-------------	---------------	----------------------	----------------	-------------	-----------------

Configuration

Motorconfiguration	CSIR
Power supply (nominal)	220-240V/50Hz 1~
Refrigerant	R404A
Application	LBP
Voltage range	198-254V
Starting torque	HST
Approvals	CCC

Electrical accessories / wiring diagram

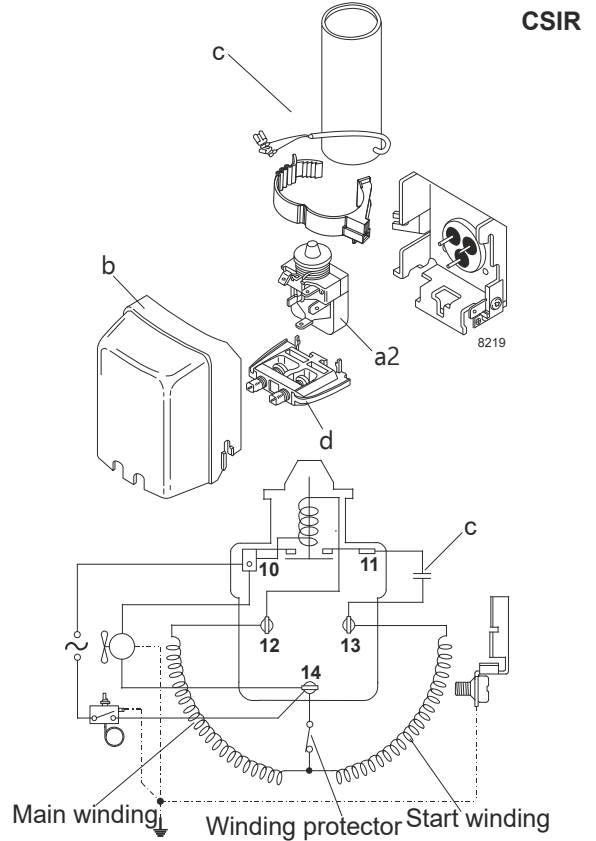

Ambient temperatures / system cooling

Ambient temperature min.:	10°C / 50°F
Ambient temperature max.:	43°C / 110°F

System cooling (n/a: outside limits)			
T ambient	LBP	MBP	HBP
32°C / 90°F	fan 3m/s	n/a	n/a
38°C / 100°F	fan 3m/s	n/a	n/a
43°C / 110°F	n/a	n/a	n/a

Operation pressure range

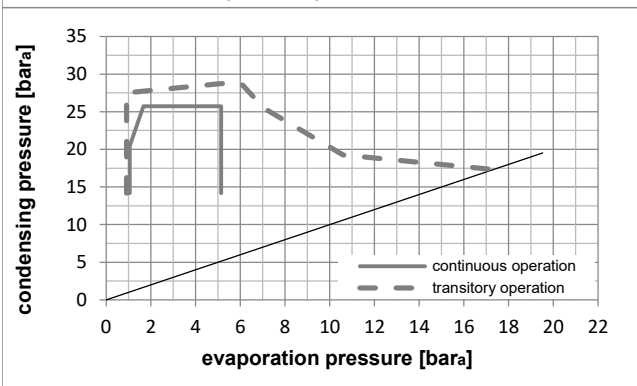
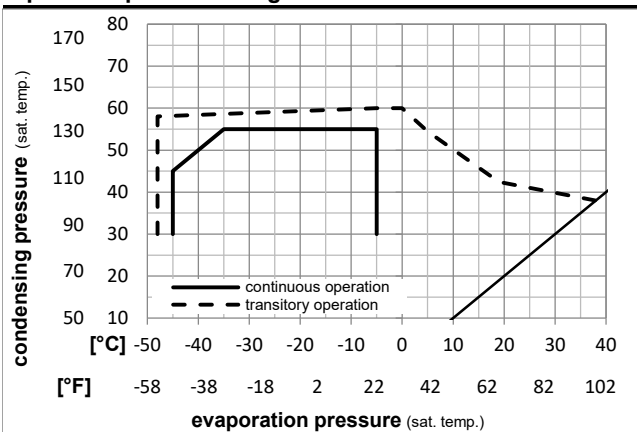

Components

a2	assy. relay	117U6003
c	start capacitor (80µF)	117U5015
b	plastic cover	103N2010
d	cord relief	103N1010

Alternative components

b	plastic cover	103N2011
---	---------------	----------

Model

Designation **NL9CLX 220-240V/50Hz** Conf. 1 Sales code: **105F3802**

Optimization + standard conditions

R404A, 220V/50Hz, CSIR, fan 3m/s, CCC

		Evaporating pressure (saturation temperature)				Condensing pressure (saturation temperature)					Power consumption				
						Return gas temp.					Current consumption				
						Liquid temp.									
						Cooling capacity					COP EER				
											P1 I m				
		pe	pc	RGT	Tliq	[W]	[Btu/h]	[kcal/h]	[W/W]	[Btu/Wh]	[kcal/Wh]	[W]	[A]	[kg/h]	
[°C]	-23,3	54,4	32,2	32,2	456,1	1558	392,6	1,34	4,57	1,15	340,9	2,11	10,63	ASHRAE LBP	
[°F]	-10	130	90	90											
[°C]	-25	55	32	55	310,0	1059	266,8	0,95	3,24	0,82	326,4	2,06	9,69	cecomaf LBP	
[°F]	-13	131	89,6	131											
[°C]	-35	40	20	40	244,0	833	209,9	1,02	3,49	0,88	238,4	1,78	6,63	EN12900 LBP	
[°F]	-31	104	68	104											
[°C]	-23,3	48,9	4,44	48,9	338,7	1157	291,5	1,02	3,47	0,88	333,1	2,08	11,99	ARI540 LBP	
[°F]	-10	120	40	120											
[°C]	-23,3	40,6	32,2	32,2	510,9	1745	439,7	1,60	5,46	1,38	319,7	2,04	11,90	AHAM LBP	
[°F]	-10	105	90	90											
[°C]	-35	45	32	45	229,9	785	197,8	0,96	3,26	0,82	240,6	1,79	6,15	opt	
[°F]	-31	113	89,6	113											

Performance tables

R404A, 220V/50Hz, CSIR, fan 3m/s, CCC

	pe		Cooling capacity			COP			EER		P1	I	m
	[°C]	[°F]	[W]	[Btu/h]	[kcal/h]	[W/W]	[Btu/Wh]	[kcal/Wh]	[W]	[A]	[kg/h]		
[°C / °F]	-45	-49	129,4	442	111,4	0,72	2,46	0,62	179,7	1,64	3,44		
cond. pressure	-35	-31	229,9	785	197,8	0,96	3,26	0,82	240,6	1,79	6,15		
pc= 45/113	-30	-22	303,6	1037	261,3	1,10	3,75	0,95	276,2	1,90	8,15		
return gas temp.	-25	-13	393,2	1343	338,4	1,25	4,27	1,08	314,2	2,02	10,61		
RGT= 32/90	-20	-4	498,9	1704	429,3	1,41	4,82	1,21	353,5	2,16	13,54		
liquid temp	-15	5	620,8	2120	534,3	1,58	5,39	1,36	393,2	2,30	16,96		
Tliq= 45/113	-5	23	914,3	3122	786,8	1,94	6,64	1,67	470,6	2,62	25,42		
[°C / °F]	-45	-49	89,8	307	77,3	0,51	1,73	0,44	176,9	1,62	2,76		
cond. pressure	-35	-31	174,4	596	150,1	0,72	2,46	0,62	242,3	1,79	5,39		
pc= 55/131	-30	-22	235,7	805	202,9	0,83	2,85	0,72	282,4	1,91	7,33		
return gas temp	-25	-13	310,0	1059	266,8	0,95	3,24	0,82	326,4	2,06	9,69		
RGT= 32/90	-20	-4	397,4	1357	342,0	1,06	3,64	0,92	373,1	2,23	12,50		
liquid temp	-15	5	498,1	1701	428,6	1,18	4,03	1,02	421,9	2,41	15,80		
Tliq= 55/131	-5	23	740,1	2527	636,9	1,42	4,84	1,22	521,7	2,83	23,95		