

NLE11KTK Energy-optimized Tropical Compressor R600a 115-127V 60Hz

General

| | |
|-----------------------|----------|
| Code number | 105H5942 |
| Approvals | UL984 |
| Compressors on pallet | 80 |

Application

| Application | LBP/MBP | | | |
|--|---------|----|--------------------------------|--|
| | Hz | 50 | 60 | |
| Frequency | Hz | 50 | 60 | |
| Evaporating temperature | °F | - | LBP: -20 to 10 MBP: 0 to 45 | |
| Voltage range | V | - | 95 - 135 | |
| Max. condensing temperature continuous (short) | °F | - | 140 (158) | |
| Max. winding temperature continuous (short) | °F | - | 257 (275) | |

Cooling requirements

| Frequency | Hz | 50 | | | 60 | | |
|-----------|----|-----|-----|-----|-----|-----|-----|
| | | LBP | MBP | HBP | LBP | MBP | HBP |
| 90°F | | - | - | - | S | S | - |
| 100°F | | - | - | - | S | S | - |
| 110°F | | - | - | - | S | S | - |

Remarks on application:

Fan and other accessories near the compressor have to be of "n" type protection according to IEC 79-15. MBP & commercial application only with timer function for ensuring pressure equalization, e.g. *Danfoss Electronic Thermostate type ETC1*.

Motor

| Motor type | RSIR/RSCR | | |
|---|-----------|-----|------|
| LRA (rated after 4 sec. UL984), HST LST | A | - | 28.0 |
| Cut in Current, HST LST | A | - | 18.8 |
| Resistance, main start winding (77°F) | Ω | 1.9 | 3.9 |

Design

| | | |
|-------------------------------------|--------|---------------------|
| Displacement | cu.in | 0.68 |
| Oil quantity (type) | fl.oz. | 10.14 (polyolester) |
| Maximum refrigerant charge | oz. | 5.3 |
| Free gas volume in compressor | fl.oz. | 79.7 |
| Weight without electrical equipment | lbs. | 22.0 |

Dimensions

| Height | inch | A | 7.76 |
|----------------------|----------------------------|----|----------------------|
| | | B | 7.52 |
| | | B1 | - |
| | | B2 | - |
| Suction connector | location, I.D. in. angle | C | 0.252-0.259 15° |
| | material comment | | Copper Rubber plug |
| Process connector | location, I.D. in. angle | D | 0.252-0.259 25° |
| | material comment | | Copper Rubber plug |
| Discharge connector | location, I.D. in. angle | E | 0.202-0.205 35° |
| | material comment | | Copper Rubber plug |
| Oil cooler connector | location, I.D. in. angle | F | - |
| | material comment | | - |
| Remarks: | | | |

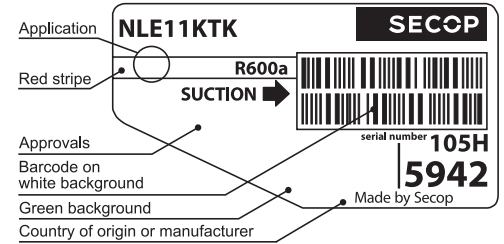

- S = Static cooling normally sufficient
- O = Oil cooling
- F₁ = Fan cooling 1.5 m/s (compressor compartment temperature equal to ambient temperature)
- F₂ = Fan cooling 3.0 m/s necessary
- SG = Suction gas cooling normally sufficient
- = not applicable in this area

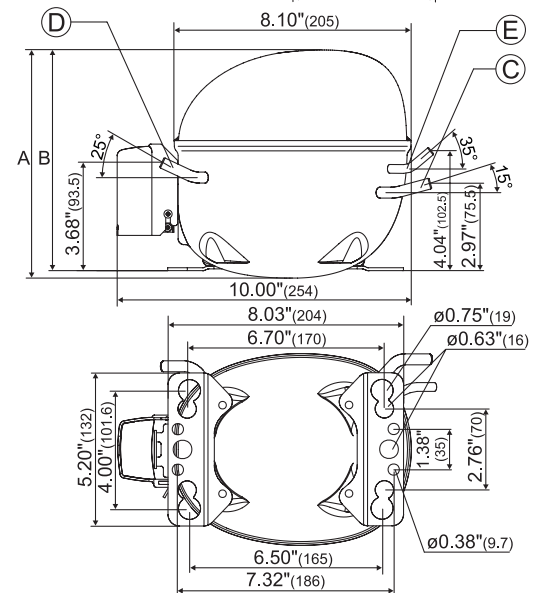
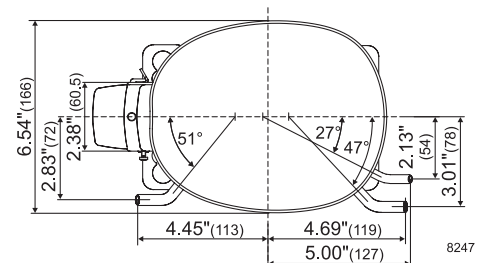

ASHRAE LBP

Static cooling 115V 60Hz, PTC consumption incl.

| | | | | | | | | | | | | | | | |
|--------------------|-----|-----|------|------|------|------|------|------|------|------|------|------|----|----|----|
| Evap. temp. in °F | -49 | -40 | -30 | -20 | -13 | -10 | 0 | 10 | 20 | 30 | 40 | 45 | 50 | 59 | 68 |
| Capacity in BTU/h | | | 363 | 493 | 612 | 671 | 892 | 1165 | 1546 | 1884 | 2224 | 2396 | | | |
| Power cons. in W | | | 114 | 138 | 154 | 161 | 182 | 202 | 246 | 272 | 295 | 304 | | | |
| Current cons. in A | | | 2.35 | 2.45 | 2.52 | 2.55 | 2.66 | 2.77 | 3.03 | 3.21 | 3.36 | 3.52 | | | |
| EER in BTU/Wh | | | 3.18 | 3.57 | 3.97 | 4.17 | 4.90 | 5.77 | 6.28 | 6.93 | 7.54 | 7.88 | | | |

ASHRAE MBP

Static cooling 115V 60Hz, PTC consumption incl.

| | | | | | | | | | | | | | | | |
|--------------------|-----|-----|------|------|------|------|------|------|------|------|------|------|----|----|----|
| Evap. temp. in °F | -49 | -40 | -30 | -20 | -13 | -10 | 0 | 10 | 20 | 30 | 40 | 45 | 50 | 59 | 68 |
| Capacity in BTU/h | | | 329 | 447 | 555 | 609 | 809 | 1057 | 1402 | 1708 | 2016 | 2171 | | | |
| Power cons. in W | | | 114 | 138 | 154 | 161 | 182 | 202 | 246 | 272 | 295 | 304 | | | |
| Current cons. in A | | | 2.35 | 2.45 | 2.52 | 2.55 | 2.66 | 2.77 | 3.03 | 3.21 | 3.36 | 3.52 | | | |
| EER in BTU/Wh | | | 2.89 | 3.24 | 3.61 | 3.78 | 4.45 | 5.23 | 5.70 | 6.28 | 6.83 | 7.14 | | | |

EN 12900 Household (CECOMAF)

Static cooling 115V 60Hz, PTC consumption incl.

| | | | | | | | | | | | | | | | |
|--------------------|-----|-----|------|------|------|------|------|------|------|------|------|------|----|----|----|
| Evap. temp. in °F | -49 | -40 | -30 | -20 | -13 | -10 | 0 | 10 | 20 | 30 | 40 | 45 | 50 | 59 | 68 |
| Capacity in W | | | 88 | 119 | 148 | 162 | 215 | 281 | 372 | 453 | 535 | 575 | | | |
| Power cons. in W | | | 114 | 138 | 154 | 161 | 182 | 202 | 246 | 272 | 295 | 304 | | | |
| Current cons. in A | | | 2.35 | 2.45 | 2.52 | 2.55 | 2.66 | 2.77 | 3.03 | 3.21 | 3.36 | 3.52 | | | |
| COP in W/W | | | 0.77 | 0.86 | 0.96 | 1.00 | 1.18 | 1.39 | 1.51 | 1.67 | 1.81 | 1.89 | | | |

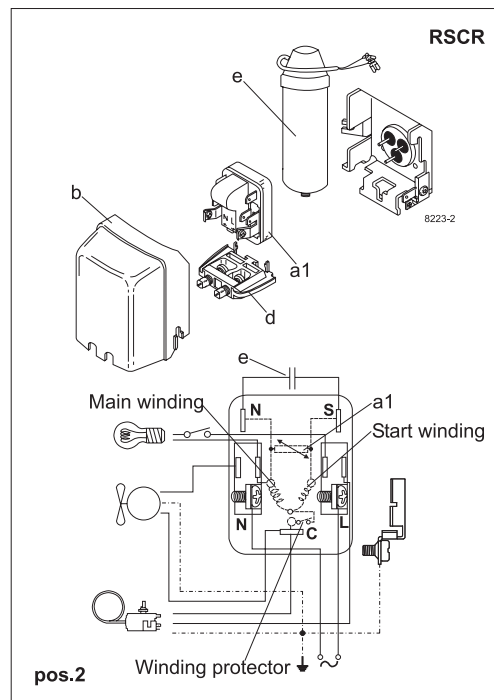
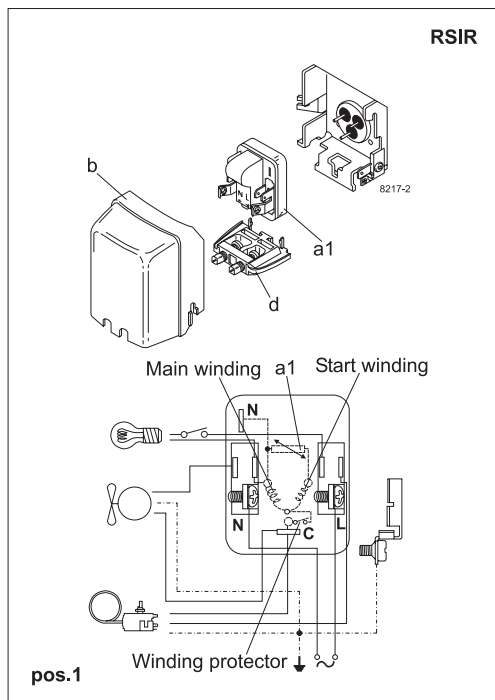

| Accessories for | NLE11KTK | Figure | Code number |
|---------------------|-------------------------|---------|-------------|
| PTC starting device | 1/4 in. spade connect. | a1 | 103N0026 |
| | 3/16 in. spade connect. | (pos.1) | 103N0023 |
| PTC starting device | 1/4 in. spade connect. | a1 | 103N0027 |
| | 3/16 in. spade connect. | (pos.2) | 103N0024 |
| Cover | | b | 103N2010 |
| Cord relief | | d | 103N1010 |
| Run capacitor | 1/4 in. spade connect. | e | 117-7118 |
| 15 µF (optional) | 3/16 in. spade connect. | | 117-7120 |

| Test conditions | ASHRAE LBP | ASHRAE MBP | EN 12900/CECOMAF |
|--------------------|------------|------------|------------------|
| Condensing temp. | 130°F | 130°F | 131°F |
| Ambient temp. | 90°F | 95°F | 90°F |
| Suction gas temp. | 90°F | 95°F | 90°F |
| Liquid temperature | 90°F | 115°F | 131°F |

| Mounting accessories | Code number | |
|--------------------------|-------------|----------|
| Bolt joint for one comp. | Ø: 5/8 in. | 118-1917 |
| Bolt joint in quantities | Ø: 5/8 in. | 118-1918 |
| Snap-on in quantities | Ø: 5/8 in. | 118-1919 |

Secop accepts no responsibility for possible errors in catalogs, brochures, and other printed material. Secop reserves the right to alter its products without notice. This also applies to products already on order provided that such alterations can be made without consequential changes being necessary to specifications already agreed. All trademarks in this material are the property of the respective companies. Secop and the Secop logotype are trademarks of Secop GmbH. All rights reserved. www.secop.com