

NLE12.6MFT Energy-optimized Tropical Compressor R134a 220-240V 50/60Hz

General

Code number	105G6388
Approvals	EN 60335-2-34 w. Annex AA
Compressors on pallet	80

Application

Application	LBP/MBP	LBP
Frequency	Hz 50	60
Evaporating temperature	°C -35 to 10	-35 to 0
Voltage range	V 187 - 254	198 to 254
Max. condensing temperature continuous (short)	°C 65 (70)	65 (70)
Max. winding temperature continuous (short)	°C 125 (135)	125 (135)

Cooling requirements

Frequency	Hz	50			60		
Application		LBP	MBP	HBP	LBP	MBP	HBP
32°C		F ₂	F ₂	-	F ₂	-	-
38°C		F ₂	F ₂	-	F ₂	-	-
43°C		F ₂	F ₂	-	F ₂	-	-
Remarks on application:							

Motor

Motor type		CSIR/RSIR/RSCR	
LRA (rated after 4 sec. UL984), HST LST	A	13.7	14.4
Cut in Current, HST LST	A	13.7	19.4
Resistance, main start winding (25°C)	Ω	4.9	8.9

Design

Displacement	cm ³	12.55
Oil quantity (type)	cm ³	300 (polyolester)
Maximum refrigerant charge	g	600
Free gas volume in compressor	cm ³	2360
Weight without electrical equipment	kg	11.5

Dimensions

Height	mm	A	203
		B	197
		B1	-
		B2	-
Suction connector	location/I.D. mm angle	C	8.2 15°
	material comment		Copper Rubber plug
Process connector	location/I.D. mm angle	D	6.2 25°
	material comment		Copper Rubber plug
Discharge connector	location/I.D. mm angle	E	6.2 21°
	material comment		Copper Rubber plug
Oil cooler connector	location/I.D. mm angle	F	-
	material comment		-
Connector tolerance	I.D. mm		±0.09
Remarks:			

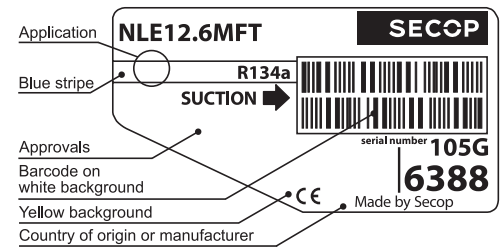

- S = Static cooling normally sufficient
- O = Oil cooling
- F₁ = Fan cooling 1.5 m/s (compressor compartment temperature equal to ambient temperature)
- F₂ = Fan cooling 3.0 m/s necessary
- SG = Suction gas cooling normally sufficient
- = not applicable in this area

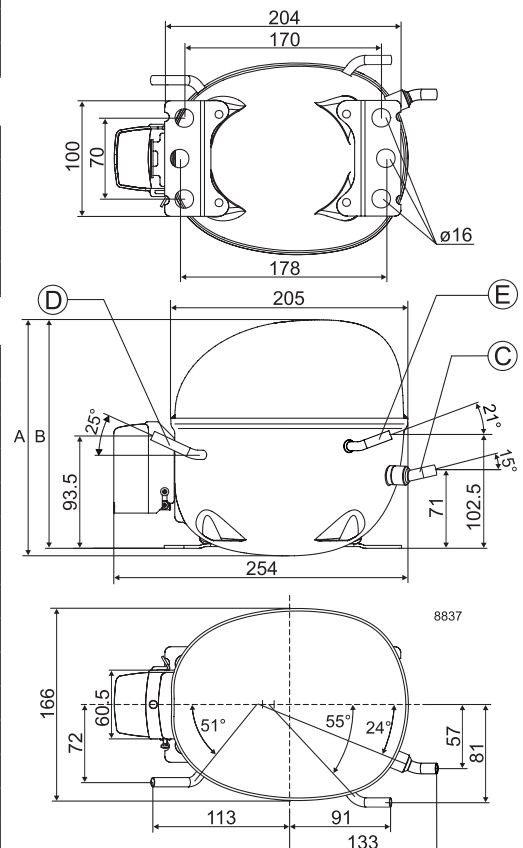

EN 12900 LBP

220V, 50Hz, fan cooling F₂

Evap. temp. in °C	-45	-40	-35	-30	-25	-23.3	-20	-15	-10	-6.7	-5	0	5	7.2	10	15	20
Capacity in W			199	254	334	367	440	572	730	848	914	1123	1360	1472	1623		
Power cons. in W			181	205	234	245	268	304	342	368	381	422	461	479	500		
Current cons. in A			1.96	1.97	2.02	2.04	2.09	2.17	2.28	2.35	2.39	2.52	2.65	2.71	2.78		
COP in W/W			1.10	1.24	1.42	1.50	1.65	1.88	2.14	2.31	2.40	2.67	2.95	3.08	3.24		

EN 12900 MBP

220V, 50Hz, fan cooling F₂

Evap. temp. in °C	-45	-40	-35	-30	-25	-23.3	-20	-15	-10	-6.7	-5	0	5	7.2	10	15	20
Capacity in W			193	236	305	335	400	521	668	779	841	1040	1265	1373	1518		
Power cons. in W			184	207	236	246	269	305	345	372	387	429	472	491	515		
Current cons. in A			1.97	1.98	2.02	2.04	2.09	2.18	2.29	2.37	2.42	2.56	2.70	2.77	2.85		
COP in W/W			1.05	1.14	1.30	1.36	1.49	1.71	1.94	2.09	2.18	2.42	2.68	2.79	2.95		

ASHRAE LBP

220V, 50Hz, fan cooling F₂

Evap. temp. in °C	-45	-40	-35	-30	-25	-23.3	-20	-15	-10	-6.7	-5	0	5	7.2	10	15	20
Capacity in W			241	268	327	355	420	545	703	826	894	1119	1378	1502	1670		
Power cons. in W			178	200	228	239	262	301	343	372	388	435	483	504	531		
Current cons. in A			1.98	1.99	2.03	2.05	2.10	2.21	2.33	2.43	2.48	2.65	2.83	2.91	3.02		
COP in W/W			1.36	1.34	1.43	1.48	1.60	1.81	2.05	2.22	2.31	2.58	2.85	2.98	3.15		

ASHRAE MBP

220V, 50Hz, fan cooling F₂

Evap. temp. in °C	-45	-40	-35	-30	-25	-23.3	-20	-15	-10	-6.7	-5	0	5	7.2	10	15	20
Capacity in W			215	239	292	317	374	486	626	735	796	995	1224	1334	1482		
Power cons. in W			176	198	226	237	260	298	339	368	384	430	477	498	524		
Current cons. in A			1.98	1.99	2.03	2.05	2.10	2.21	2.33	2.43	2.48	2.65	2.83	2.91	3.02		
COP in W/W			1.22	1.21	1.29	1.34	1.44	1.63	1.85	2.00	2.08	2.32	2.57	2.68	2.83		

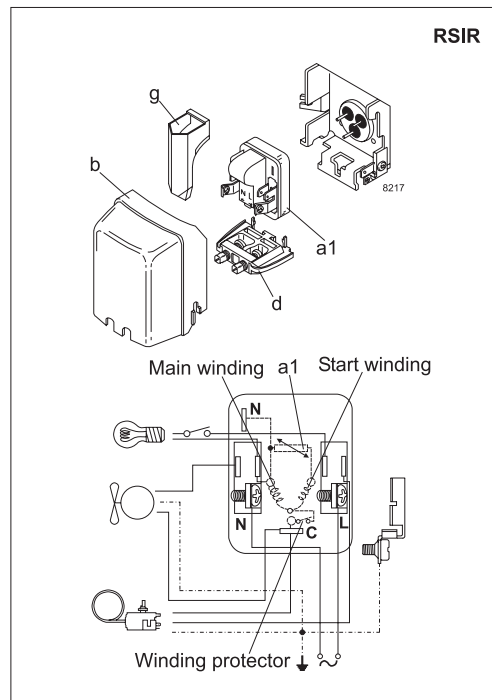
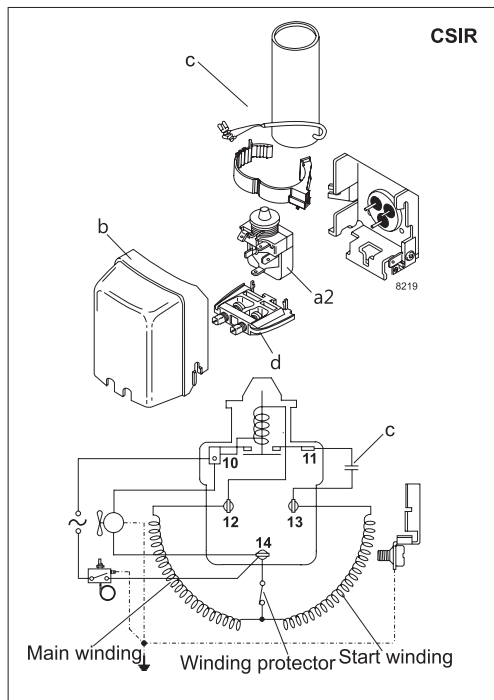

Accessories for	NLE12.6MFT	Figure	Code number
ePTC starting device	6.3 mm spade connectors	a1	-
	4.8 mm spade connectors		103N0050
Starting relay	6.3 mm spade connectors	a2	117U6005
Start. capacitor 80 µF	6.3 mm spade connectors	c	117U5015
Cover		b	103N2010
Cord relief		d	103N1010
Protection screen for PTC		g	-

Test conditions	EN 12900			
	LBP	MBP	LBP	MBP
Condensing temperature	40°C	45°C	54.4°C	54.4°C
Ambient temperature	32°C	32°C	32.2°C	35°C
Suction gas temperature	20°C	20°C	32.2°C	35°C
Liquid temperature	no subcooling		32.2°C	46.1°C

Mounting accessories	Code number	
Bolt joint for one comp.	Ø: 16 mm	118-1917
Bolt joint in quantities	Ø: 16 mm	118-1918
Snap-on in quantities	Ø: 16 mm	118-1919

EN 12900 LBP

220V, 50Hz, RC 4 µF, ePTC consumption incl., fan cooling F₂

Evap. temp. in °C	-45	-40	-35	-30	-25	-23.3	-20	-15	-10	-6.7	-5	0	5	7.2	10	15	20
Capacity in W			202	258	339	373	447	581	741	862	928	1141	1381	1495	1648		
Power cons. in W			176	200	228	239	260	295	332	358	371	410	449	465	486		
Current cons. in A			1.90	1.92	1.96	1.98	2.03	2.11	2.21	2.29	2.33	2.45	2.57	2.63	2.70		
COP in W/W			1.15	1.29	1.49	1.56	1.72	1.97	2.23	2.41	2.50	2.78	3.08	3.21	3.39		

EN 12900 MBP

220V, 50Hz, RC 4 µF, ePTC consumption incl., fan cooling F₂

Evap. temp. in °C	-45	-40	-35	-30	-25	-23.3	-20	-15	-10	-6.7	-5	0	5	7.2	10	15	20
Capacity in W			196	240	310	340	407	529	679	791	854	1056	1285	1395	1541		
Power cons. in W			179	201	229	240	261	297	335	362	376	417	459	478	501		
Current cons. in A			1.91	1.93	1.97	1.99	2.03	2.12	2.23	2.31	2.35	2.48	2.63	2.69	2.77		
COP in W/W			1.10	1.19	1.35	1.42	1.56	1.78	2.02	2.19	2.27	2.53	2.80	2.92	3.08		

ASHRAE LBP

220V, 50Hz, RC 4 µF, ePTC consumption incl., fan cooling F₂

Evap. temp. in °C	-45	-40	-35	-30	-25	-23.3	-20	-15	-10	-6.7	-5	0	5	7.2	10	15	20
Capacity in W			245	272	333	361	426	553	714	839	908	1137	1399	1526	1697		
Power cons. in W			173	194	222	233	255	292	333	362	377	423	469	490	516		
Current cons. in A			1.93	1.93	1.97	2.00	2.05	2.15	2.27	2.36	2.41	2.58	2.75	2.83	2.94		
COP in W/W			1.42	1.40	1.50	1.55	1.67	1.89	2.14	2.32	2.41	2.69	2.98	3.11	3.29		

ASHRAE MBP

220V, 50Hz, RC 4 µF, ePTC consumption incl., fan cooling F₂

Evap. temp. in °C	-45	-40	-35	-30	-25	-23.3	-20	-15	-10	-6.7	-5	0	5	7.2	10	15	20
Capacity in W			219	243	297	322	380	493	636	747	809	1011	1243	1355	1506		
Power cons. in W			171	193	220	230	252	289	330	358	373	418	464	484	510		
Current cons. in A			1.93	1.93	1.97	2.00	2.05	2.15	2.27	2.36	2.41	2.58	2.75	2.83	2.94		
COP in W/W			1.28	1.26	1.35	1.40	1.51	1.70	1.93	2.09	2.17	2.42	2.68	2.80	2.95		

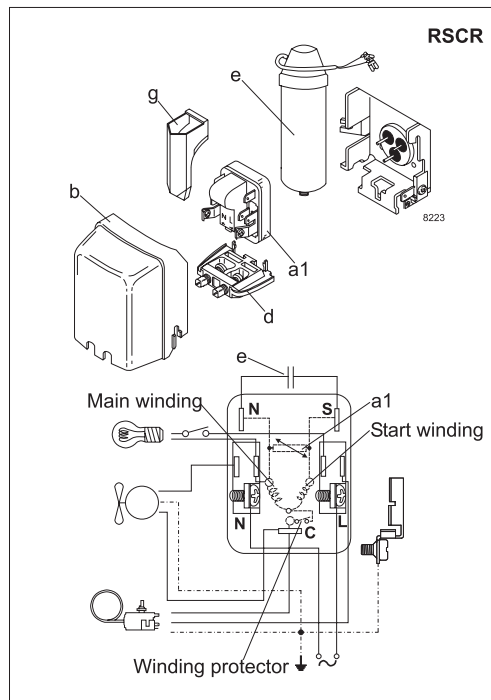

Accessories for	NLE12.6MFT	Figure	Code number
ePTC starting device	6.3 mm spade connectors	a1	-
	4.8 mm spade connectors		103N0050
Run capacitor 4 µF (optional)	4.8 mm spade connectors	e	117-7119
Cover		b	103N2010
Cord relief		d	103N1010
Protection screen for PTC		g	-

Test conditions	EN 12900		ASHRAE	
	LBP	MBP	LBP	MBP
Condensing temperature	40°C	45°C	54.4°C	54.4°C
Ambient temperature	32°C	32°C	32.2°C	35°C
Suction gas temperature	20°C	20°C	32.2°C	35°C
Liquid temperature	no subcooling		32.2°C	46.1°C

Mounting accessories	Code number	
Bolt joint for one comp.	Ø: 16 mm	118-1917
Bolt joint in quantities	Ø: 16 mm	118-1918
Snap-on in quantities	Ø: 16 mm	118-1919

Secop accepts no responsibility for possible errors in catalogs, brochures, and other printed material. Secop reserves the right to alter its products without notice. This also applies to products already on order provided that such alterations can be made without consequential changes being necessary to specifications already agreed. All trademarks in this material are the property of the respective companies. Secop and the Secop logotype are trademarks of Secop GmbH. All rights reserved. www.secop.com