

Model

Designation	NLE13MNDX	220-240V/50Hz 1~	Sales code:	105H7302
-------------	------------------	------------------	-------------	-----------------

Compressor design

Oil type	Polyolester	Refrigerant(s)	R290
Oil viscosity	32cSt	Displacement	12,6cm ³ / 0,77cu.in
Oil quantity	298cm ³ / 10,1fl.oz	Compressors on pallet	
Refr. charge - tech. limit	300g / 10,6oz		
Free gas volume comp.	2360cm ³ / 79,8fl.oz		
Weight	11,8kg / 26lbs		
Motor protection	external		
Winding resistance main	7,5Ω (at 25°C)		
Winding resistance aux	12,9Ω (at 25°C)		
Max. winding temp.	125°C / 257°F		
Max. discharge temp.	130°C / 266°F		



General - Configurations with NLE13MNDX

Conf. 1	
Motor configuration	CSCR
Power supply (nominal)	220-240V/50Hz
Number of phases	1
Voltage range	198-254V
Approvals	VDE
Starting torque	HST
Note	- / -

Applications with NLE13MNDX

Conf. 1	
Refrigerant	R290
Application	MBP
System cooling	fan 3m/s
Hot gas defrost	OK
Long interval pull down	OK

Electrical data - Configurations with NLE13MNDX

Conf. 1	
Starting device type	relay
Run capacitor	10μF
Start capacitor	80μF
LRA (locked rotor amps / 4s/ U(N))	16,7A
RLA (rated load amps / 1s/ U(N))	2,2A
Cut in current (U(N))	16,7A

Model

Designation **NLE13MNDX** 220-240V/50Hz 1~ Sales code: **105H7302**

Compressor dimensions

Housing	A Height	209mm / 8,23in
	B Height	203mm / 7,99in
	C Length shell	205mm / 8,07in
	D Length w. cover	262mm / 10,31in
	E Width	166mm / 6,54in

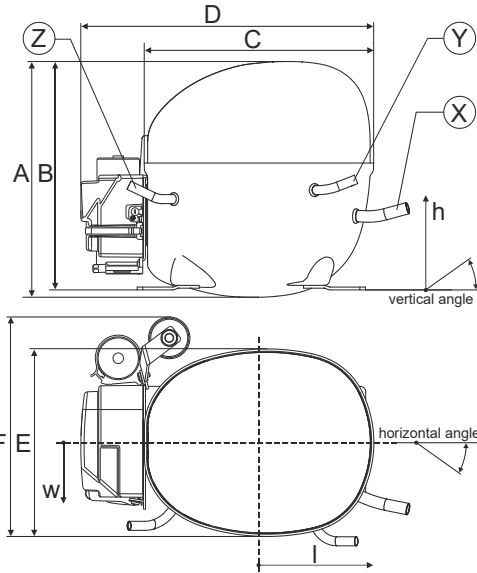

Connectors		Suction	Discharge	Process
		X	Y	Z
Diameter	[mm]	øi 8,11-8,29	øi 6,11-6,29	øi 6,11-6,29
(i:inside, o:outside)	[in]	øi 0,32-0,33	øi 0,24-0,25	øi 0,24-0,25
Material		copper	copper	copper
Horizontal angle	±2°	11°	0°	0°
Vertical angle	±2°	15°	21°	25°
Position l/h/w	[mm]	140/72/59	94/98/87	-109/93/74
	[in]	5,5/2,8/2,3	3,7/3,9/3,4	-4,3/3,7/2,9
Straight tube l.	[mm]	12	12	12
	[in]	0,5	0,5	0,5

Compressor fixation

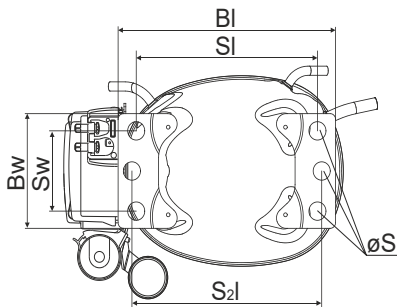

Baseplate	[mm]	[inch]
BI	204	8.03
Bw	100	3.94
Small holes		
	[mm]	[inch]
SI	170	6.7
Sw	70	2.76
S2l	178	7
øS	ø 16	ø 0.63

Bolt joint

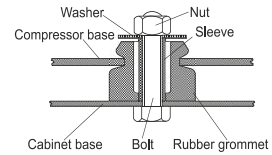

Snap-on

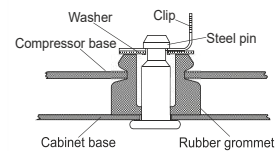

Mounting accessories	one comp.	multi pack
Bolt joint M6 ø16mm	118-1917	118-1918
Bolt joint ø1/4" ø16mm	118-1946	
Snap-on ø7,3 ø16mm	118-1947	118-1919

Application notes

Provision for PE Grounding is located at the PE Stamp on the compressor

Model

Designation **NLE13MNDX** **220-240V/50Hz** Conf. 1 Sales code: **105H7302**

Configuration

Motor configuration CSCR
 Power supply (nominal) 220-240V/50Hz 1~
 Refrigerant R290
 Application MBP
 Voltage range 198-254V
 Starting torque HST
 Approvals VDE

Electrical accessories / wiring diagram

CSCR

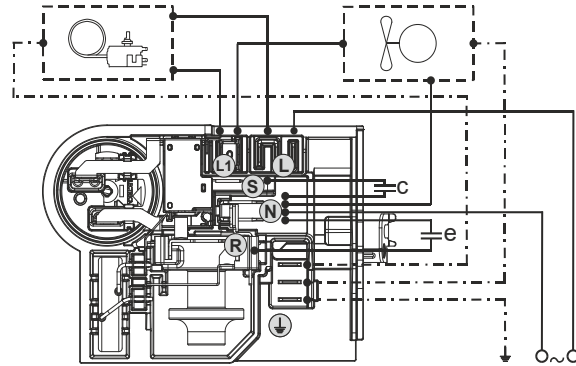
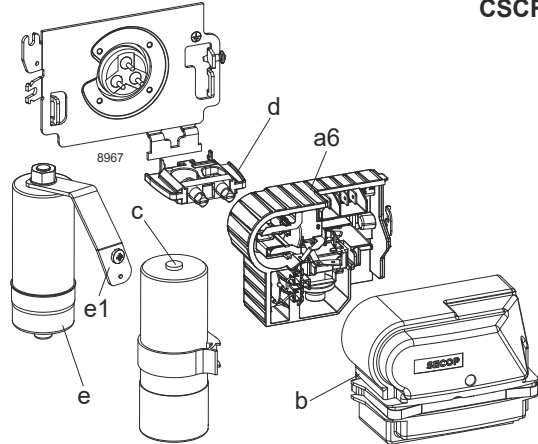

Ambient/ machine room temperatures minimum /maximum

Ambient temperature range: 10 - 43°C / 50 - 110°F

Machine room temperature range: 10 - 48°C / 50 - 119°F

Compressor cooling: fan 3m/s

Operation pressure range

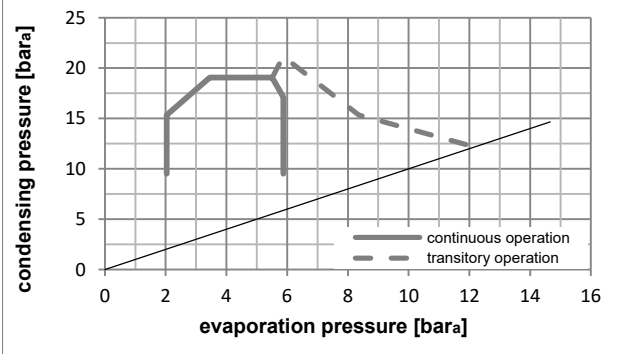
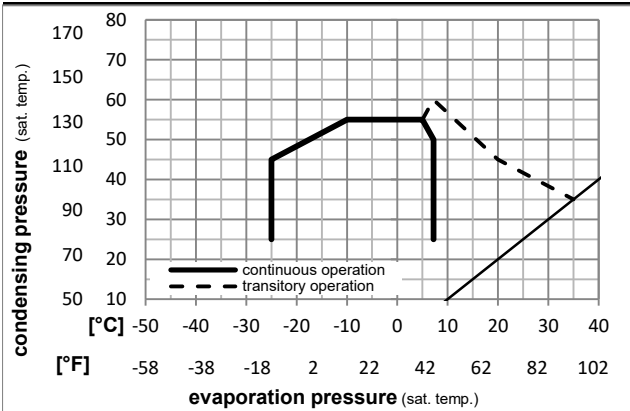

Components

a6	NL starter kit	117U8201
c	start capacitor (80µF)	117U5353
e	run cap (10µF, 6.3mm,c.length 280mm)	117-7166
b	cover terminal board + clamp	117U1038
e1	retaining clamp	117-0314
	screw M4x8mm	117-0301
d	cord relief	103N1007

Model

Designation **NLE13MNDX 220-240V/50Hz** Conf. 1 Sales code: **105H7302**

Optimization + standard conditions

R290, 220V/50Hz, CSCR, fan 3m/s, VDE

		Evaporating pressure (saturation temperature)				Cooling capacity			COP			EER			Power consumption		
		Condensing pressure (saturation temperature)				Return gas temp.			Liquid temp.			P1			Current consumption		
		Ref. mass flow				I			m								
		pe	pc	RGT	Tliq	[W]	[Btu/h]	[kcal/h]	[W/W]	[Btu/Wh]	[kcal/Wh]	[W]	[A]	[kg/h]			
[°C]	[°F]	[°C]	[°F]	[°C]	[°F]												
-7	20	54	130	35	95	46	115	1136,7	3882	978,2	2,09	7,14	1,80	544,0	2,55	12,97	ASHRAE MBP
-10	14	55	131	32	90	55	131	906,1	3095	779,8	1,75	5,99	1,51	516,3	2,43	11,46	cecomaf MBP
-10	14	45	113	20	68	45	113	1015,3	3468	873,8	2,19	7,49	1,89	463,2	2,19	12,47	EN12900 MBP
-7	20	49	120	18	65	49	120	1072,0	3661	922,6	2,11	7,21	1,82	507,8	2,39	13,92	ARI540 MBP
-10	14	45	113	32	90	45	113	1057,0	3610	909,7	2,28	7,79	1,96	463,2	2,19	12,09	opt
-25	-13	45	113	32	90	45	113	569,7	1946	490,3	1,60	5,48	1,38	355,1	1,73	6,43	opt

Performance tables

R290, 220V/50Hz, CSCR, fan 3m/s, VDE

	pe		Cooling capacity			COP			EER			P1	I	m
	[°C]	[°F]	[W]	[Btu/h]	[kcal/h]	[W/W]	[Btu/Wh]	[kcal/Wh]	[W]	[A]	[kg/h]			
[°C / °F]	-25	-13	569,7	1946	490,3	1,60	5,48	1,38	355,1	1,73	6,43			
cond. pressure	-20	-4	710,1	2425	611,2	1,82	6,20	1,56	391,0	1,88	8,04			
pc= 45/113	-15	5	872,2	2979	750,6	2,04	6,96	1,75	427,7	2,03	9,92			
return gas temp.	-10	14	1057,0	3610	909,7	2,28	7,79	1,96	463,2	2,19	12,09			
RGT= 32/90	-5	23	1265,9	4323	1089,5	2,56	8,73	2,20	495,3	2,33	14,58			
liquid temp	0	32	1500,1	5123	1291,0	2,87	9,81	2,47	522,0	2,45	17,40			
Tliq= 45/113	7,2	45	1884,3	6435	1621,6	3,45	11,77	2,97	546,8	2,56	22,14			
[°C / °F]	-25	-13	484,2	1654	416,7	1,30	4,44	1,12	372,2	1,80	6,03			
cond. pressure	-20	-4	605,4	2067	521,0	1,44	4,93	1,24	419,0	2,00	7,57			
pc= 55/131	-15	5	745,6	2546	641,7	1,59	5,44	1,37	467,7	2,21	9,37			
return gas temp	-10	14	906,1	3095	779,8	1,75	5,99	1,51	516,3	2,43	11,46			
RGT= 32/90	-5	23	1088,2	3716	936,5	1,93	6,60	1,66	562,8	2,63	13,86			
liquid temp	0	32	1293,0	4416	1112,7	2,14	7,30	1,84	604,9	2,82	16,61			
Tliq= 55/131	7,2	45	1630,3	5568	1403,1	2,49	8,51	2,15	653,9	3,05	21,24			