

Model

Designation	NLE15KK.4	220-240V/50Hz 1~	Sales code:	105H6906
-------------	------------------	-------------------------	-------------	-----------------

Compressor design

Oil type	Mineral	Refrigerant(s)	R600a
Oil viscosity	15cSt	Displacement	14,65cm ³ / 0,89cu.in
Oil quantity	320cm ³ / 10,8fl.oz	Compressors on pallet	80
Refr. charge - tech. limit	150g / 5,3oz		
Free gas volume comp.	2310cm ³ / 78,1fl.oz		
Weight	10,8kg / 23,8lbs		
Motor protection	1# internal		
Winding resistance main	10,7Ω (at 25°C)		
Winding resistance aux	13Ω (at 25°C)		
Max. winding temp.	125°C / 257°F		
Max. discharge temp.	130°C / 266°F		



General - Configurations with NLE15KK.4

	Conf. 1	Conf. 2	Conf. 3	Conf. 4
Motorconfiguration	RSIR	RSCR	RSCR	RSCR
Power supply (nominal)	220-240V/50Hz	220-240V/50Hz	220-240V/50Hz	220-240V/50Hz
Number of phases	1	1	1	1
Voltage range	198-254V	198-254V	198-254V	198-254V
Approvals	VDE	VDE	VDE	VDE
Starting torque	LST	LST	LST	LST
Note	- / -			

Applications with NLE15KK.4

	Conf. 1	Conf. 2	Conf. 3	Conf. 4
Refrigerant	R600a	R600a	R600a	R600a
Application	LBP	LBP	LBP	LBP
System cooling	static	static	static	static
Hot gas defrost	- / -	- / -	- / -	- / -
Long interval pull down	- / -	- / -	- / -	- / -

Electrical data - Configurations with NLE15KK.4

	Conf. 1	Conf. 2	Conf. 3	Conf. 4
Starting device type	PTC	PTC	PTC	PTC
Run capacitor	- / -	4μF	4μF	4μF
Start capacitor	- / -	- / -	- / -	- / -
LRA (locked rotor amps / 4s)	6,6A	6,6A	6,6A	6,6A
RLA (rated load amps / 1s)	1,3A	1,2A	1,2A	1,2A
Cut in current	10,9A	10,9A	10,9A	10,9A
IP class	21	21	21	21

Model

Designation	NLE15KK.4	220-240V/50Hz 1~	Sales code:	105H6906
-------------	------------------	------------------	-------------	-----------------

Compressor dimensions

Housing	A Height	197mm / 7,76in
	B Height	190mm / 7,48in
	C Length shell	205mm / 8,07in
	D Length w. cover	254mm / 10in
	E Width	166mm / 6,54in

Connectors		Suction	Discharge	Process
		X	Y	Z
Diameter	[mm]	øi 8,11-8,29	øi 6,11-6,29	øi 6,11-6,29
(i:inside, o:outside)	[in]	øi 0,32-0,33	øi 0,24-0,25	øi 0,24-0,25
Material		copper	copper	copper
Horizontal angle	±2°	0°	0°	0°
Vertical angle	±2°	15°	35°	155°
Position l/h/w	[mm]	126/76/78	133/103/54	-107/94/72
	[in]	5/3/3,1	5,2/4/2,1	-4,2/3,7/2,8
Straight tube l.	[mm]	12	12	12
	[in]	0,5	0,5	0,5

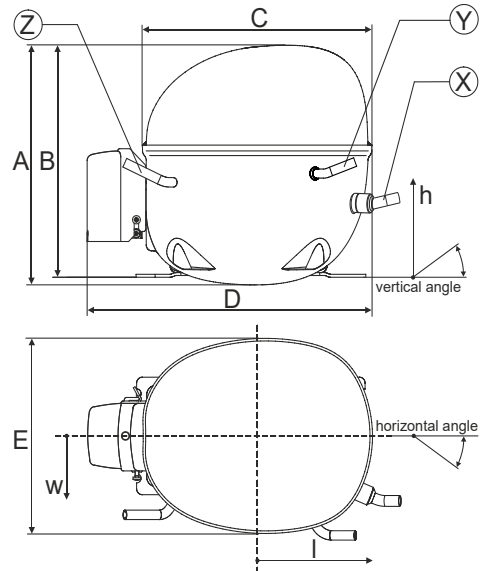

Compressor fixation

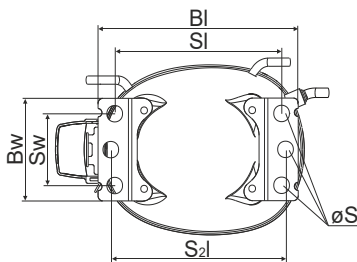

Baseplate	[mm]	[inch]
BI	204	8.03
BW	100	3.94
Small holes		
SI	170	6.7
SW	70	2.76
S2I	178	7
øS	ø 16	ø 0.63

Bolt joint

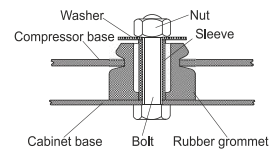

Snap-on

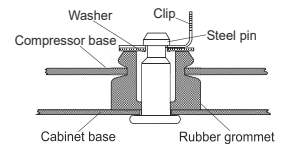

Mounting accessories

	one comp.	multi pack
Bolt joint M6 ø16mm	118-1917	118-1918
Bolt joint ø1/4" ø16mm	118-1946	
Snap-on ø7,3 ø16mm	118-1947	118-1919

Model

Designation	NLE15KK.4	220-240V/50Hz	Conf. 1	Sales code:	105H6906
-------------	------------------	----------------------	----------------	-------------	-----------------

Configuration

Motorconfiguration	RSIR
Power supply (nominal)	220-240V/50Hz 1~
Refrigerant	R600a
Application	LBP
Voltage range	198-254V
Starting torque	LST
Approvals	VDE

Electrical accessories / wiring diagram

RSIR

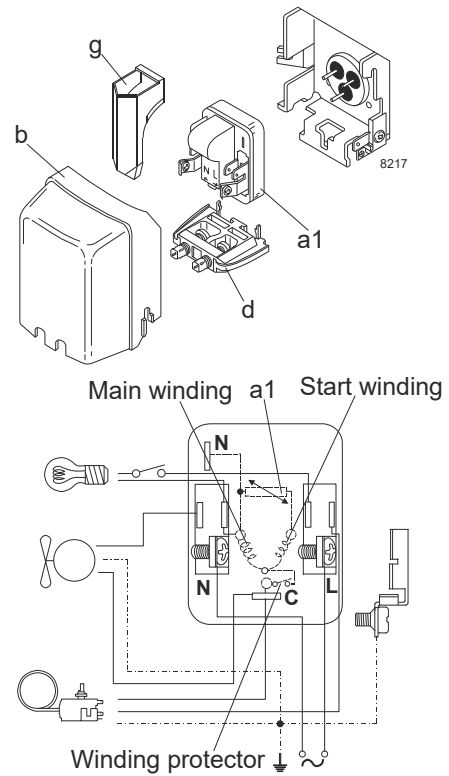

Ambient temperatures / system cooling

Ambient temperature min.:	10°C / 50°F
Ambient temperature max.:	43°C / 110°F

System cooling (n/a: outside limits)			
T ambient	LBP	MBP	HBP
32°C / 90°F	static	n/a	n/a
38°C / 100°F	static	n/a	n/a
43°C / 110°F	static	n/a	n/a

Operation pressure range

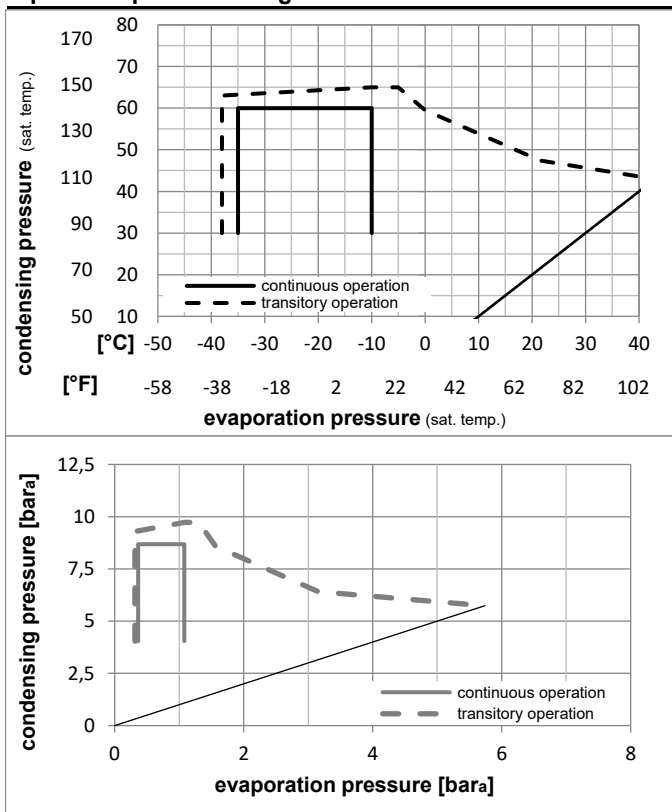

Components

a1	PTC starter (220V, 25Ohm, 4.8mm)	103N0018
b	plastic cover	103N2010
d	cord relief	103N1010
g	protection screen for PTC	103N0476

Alternative components

a1	PTC starter (220V, 25Ohm, 6.3mm)	103N0011
b	plastic cover	103N2011
d	cord relief	103N1010
g	protection screen for PTC	103N0476

Model

Designation **NLE15KK.4 220-240V/50Hz** Conf. 1 Sales code: **105H6906**

Optimization + standard conditions

220V/50Hz, RSIR, static, VDE

	Evaporating pressure (saturation temperature)				Condensing pressure (saturation temperature)						Power consumption			ASHRAE LBP
	pe	pc	RGT	Tliq	Cooling capacity			COP	EER	P1	I	Ref. mass flow		
	[°C]	[°C]	[°C]	[°C]	[W]	[Btu/h]	[kcal/h]	[W/W]	[Btu/Wh]	[kcal/Wh]	[W]	[A]	[kg/h]	
	-23,3	54,4	32,2	32,2	252,1	861	216,9	1,53	5,23	1,32	164,7	1,09	2,71	ASHRAE LBP
	[-10]	130	90	90										
	-25	55	32	55	190,0	649	163,5	1,20	4,11	1,04	158,0	1,07	2,48	cecomaf LBP
	[-13]	131	89,6	131										
	-35	40	20	40	136,0	464	117,0	1,15	3,92	0,99	118,3	0,93	1,65	EN12900 LBP
	[-31]	104	68	104										
	-23,3	48,9	4,44	48,9	205,5	702	176,9	1,28	4,36	1,10	160,9	1,08	3,00	ARI540 LBP
	[-10]	120	40	120										
	-23,3	40,6	32,2	32,2	271,8	928	233,9	1,76	6,00	1,51	154,6	1,06	2,92	AHAM LBP
	[-10]	105	90	90										
	-35	45	32	45	130,3	445	112,2	1,09	3,72	0,94	119,5	0,94	1,55	opt
	[-31]	113	89,6	113										

Performance tables

220V/50Hz, RSIR, static, VDE

	pe	Cooling capacity			COP	EER	P1	I	m		
	[°C]	[°F]	[W]	[Btu/h]	[kcal/h]	[W/W]	[Btu/Wh]	[kcal/Wh]	[W]	[A]	[kg/h]
[°C / °F]	-35	-31	130,3	445	112,2	1,09	3,72	0,94	119,5	0,94	1,55
cond. pressure	-30	-22	171,2	585	147,4	1,27	4,33	1,09	134,9	0,98	2,04
pc= 45/113	-25	-13	220,9	754	190,1	1,46	4,97	1,25	151,8	1,04	2,63
return gas temp.	-23,3	-10	240,0	820	206,6	1,52	5,18	1,31	158,1	1,07	2,86
RGT= 32/90	-20	-4	280,7	958	241,5	1,64	5,59	1,41	171,4	1,13	3,35
liquid temp	-15	5	351,6	1201	302,6	1,81	6,17	1,56	194,6	1,23	4,20
Tliq= 45/113	-10	14	435,1	1486	374,5	1,95	6,67	1,68	222,6	1,35	5,21
[°C / °F]	-35	-31	109,6	374	94,4	0,92	3,15	0,79	119,0	0,94	1,43
cond. pressure	-30	-22	145,9	498	125,6	1,06	3,61	0,91	138,0	0,99	1,90
pc= 55/131	-25	-13	190,0	649	163,5	1,20	4,11	1,04	158,0	1,07	2,48
return gas temp	-23,3	-10	207,0	707	178,2	1,25	4,28	1,08	165,2	1,09	2,70
RGT= 32/90	-20	-4	243,2	831	209,3	1,35	4,61	1,16	180,1	1,16	3,18
liquid temp	-15	5	306,7	1047	263,9	1,49	5,10	1,29	205,3	1,27	4,02
Tliq= 55/131	-10	14	381,7	1304	328,5	1,63	5,55	1,40	234,8	1,40	5,01

Model

Designation	NLE15KK.4	220-240V/50Hz	Conf. 2	Sales code:	105H6906
-------------	------------------	----------------------	----------------	-------------	-----------------

Configuration

Motorconfiguration	RSCR
Power supply (nominal)	220-240V/50Hz 1~
Refrigerant	R600a
Application	LBP
Voltage range	198-254V
Starting torque	LST
Approvals	VDE

Electrical accessories / wiring diagram

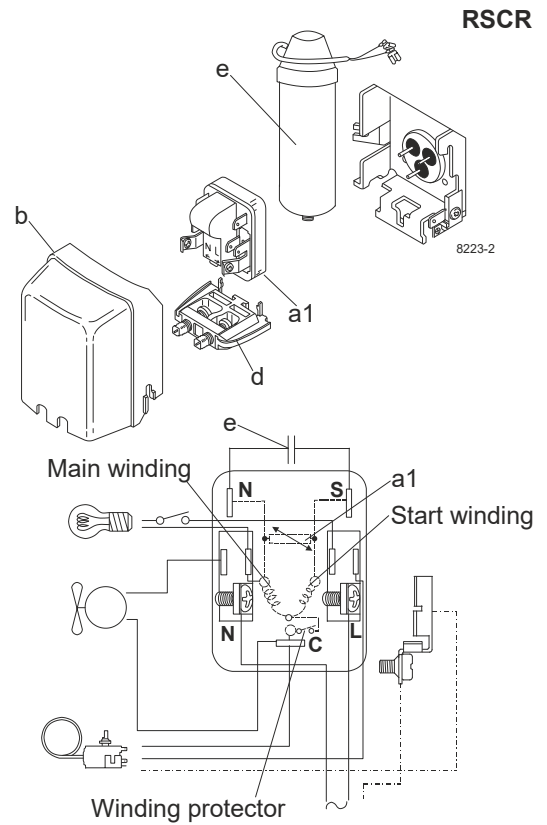

Ambient temperatures / system cooling

Ambient temperature min.:	10°C / 50°F
Ambient temperature max.:	43°C / 110°F

System cooling (n/a: outside limits)			
T ambient	LBP	MBP	HBP
32°C / 90°F	static	n/a	n/a
38°C / 100°F	static	n/a	n/a
43°C / 110°F	static	n/a	n/a

Operation pressure range

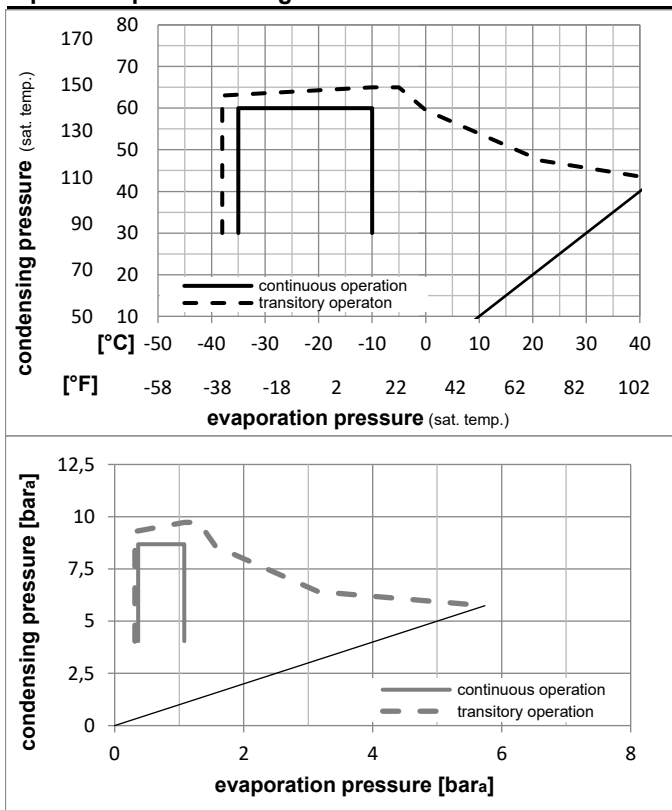

Components

a1	e-PTC starter (220V, 250hm, 4.8mm)	103N0050
e	run capacitor (4μF, 4.8mm)	117-7119
b	plastic cover	103N2010
d	cord relief	103N1010
	bracket for run capacitor	117-0300
	screw M4x8mm	117-0301

Alternative components

b	plastic cover	103N2011
---	---------------	----------

Model

Designation **NLE15KK.4 220-240V/50Hz** Conf. **2** Sales code: **105H6906**

Optimization + standard conditions

220V/50Hz, RSCR, static, VDE

	Evaporating pressure (saturation temperature)				Condensing pressure (saturation temperature)						Power consumption			ASHRAE LBP
	pe	pc	RGT	Tliq	Cooling capacity			COP	EER	P1	I	Ref. mass flow		
	[°C]	[°C]	[°C]	[°C]	[W]	[Btu/h]	[kcal/h]	[W/W]	[Btu/Wh]	[kcal/Wh]	[W]	[A]	[kg/h]	
	-23,3	54,4	32,2	32,2	252,1	861	216,9	1,59	5,43	1,37	158,6	0,88	2,71	ASHRAE LBP
	[-10]	130	90	90										
	-25	55	32	55	190,0	649	163,5	1,25	4,26	1,07	152,2	0,84	2,48	cecomaf LBP
	[-13]	131	89,6	131										
	-35	40	20	40	136,0	464	117,0	1,19	4,06	1,02	114,3	0,65	1,65	EN12900 LBP
	[-31]	104	68	104										
	-23,3	48,9	4,44	48,9	205,5	702	176,9	1,33	4,53	1,14	155,0	0,86	3,00	ARI540 LBP
	[-10]	120	40	120										
	-23,3	40,6	32,2	32,2	271,8	928	233,9	1,83	6,24	1,57	148,7	0,83	2,92	AHAM LBP
	[-10]	105	90	90										
	-35	45	32	45	130,3	445	112,2	1,13	3,85	0,97	115,6	0,66	1,55	opt
	[-31]	113	89,6	113										

Performance tables

220V/50Hz, RSCR, static, VDE

	pe	Cooling capacity			COP	EER	P1	I	m		
	[°C]	[°F]	[W]	[Btu/h]	[kcal/h]	[W/W]	[Btu/Wh]	[kcal/Wh]	[W]	[A]	[kg/h]
[°C / °F]	-35	-31	130,3	445	112,2	1,13	3,85	0,97	115,6	0,66	1,55
cond. pressure	-30	-22	171,2	585	147,4	1,31	4,48	1,13	130,4	0,73	2,04
pc= 45/113	-25	-13	220,9	754	190,1	1,51	5,15	1,30	146,5	0,82	2,63
return gas temp.	-23,3	-10	240,0	820	206,6	1,58	5,38	1,36	152,4	0,85	2,86
RGT= 32/90	-20	-4	280,7	958	241,5	1,71	5,82	1,47	164,6	0,92	3,35
liquid temp	-15	5	351,6	1201	302,6	1,89	6,47	1,63	185,6	1,03	4,20
Tliq= 45/113	-10	14	435,1	1486	374,5	2,07	7,06	1,78	210,4	1,16	5,21
[°C / °F]	-35	-31	109,6	374	94,4	0,95	3,26	0,82	114,9	0,66	1,43
cond. pressure	-30	-22	145,9	498	125,6	1,10	3,74	0,94	133,2	0,75	1,90
pc= 55/131	-25	-13	190,0	649	163,5	1,25	4,26	1,07	152,2	0,84	2,48
return gas temp	-23,3	-10	207,0	707	178,2	1,30	4,45	1,12	159,0	0,88	2,70
RGT= 32/90	-20	-4	243,2	831	209,3	1,41	4,80	1,21	172,9	0,96	3,18
liquid temp	-15	5	306,7	1047	263,9	1,56	5,34	1,35	196,1	1,08	4,02
Tliq= 55/131	-10	14	381,7	1304	328,5	1,71	5,86	1,48	222,6	1,22	5,01

Model

Designation	NLE15KK.4	220-240V/50Hz	Conf. 3	Sales code:	105H6906
-------------	------------------	----------------------	----------------	-------------	-----------------

Configuration

Motorconfiguration	RSCR
Power supply (nominal)	220-240V/50Hz 1~
Refrigerant	R600a
Application	LBP
Voltage range	198-254V
Starting torque	LST
Approvals	VDE

Electrical accessories / wiring diagram

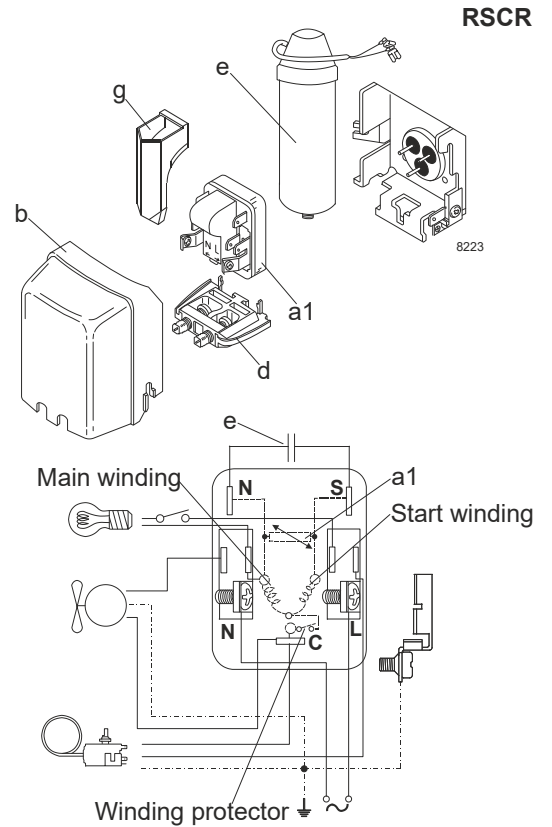

Ambient temperatures / system cooling

Ambient temperature min.:	10°C / 50°F
Ambient temperature max.:	43°C / 110°F

System cooling (n/a: outside limits)			
T ambient	LBP	MBP	HBP
32°C / 90°F	static	n/a	n/a
38°C / 100°F	static	n/a	n/a
43°C / 110°F	static	n/a	n/a

Operation pressure range

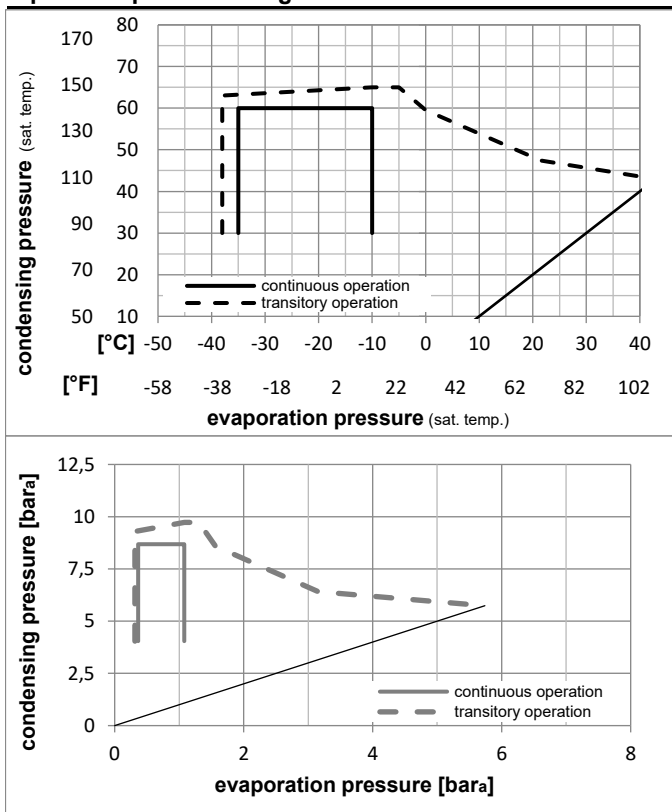

Components

a1	PTC starter (220V, 250hm, 4.8mm)	103N0021
e	run capacitor (4μF, 4.8mm)	117-7119
b	plastic cover	103N2010
d	cord relief	103N1010
g	protection screen for PTC	103N0476
	bracket for run capacitor	117-0300

Alternative components

b	plastic cover	103N2011
---	---------------	----------

Model

Designation **NLE15KK.4 220-240V/50Hz** Conf. **3** Sales code: **105H6906**

Optimization + standard conditions

220V/50Hz, RSCR, static, VDE

	Evaporating pressure (saturation temperature)				Condensing pressure (saturation temperature)						Power consumption			ASHRAE LBP
	pe	pc	RGT	Tliq	Cooling capacity			COP	EER	P1	I	Ref. mass flow		
	[°C]	[°C]	[°C]	[°C]	[W]	[Btu/h]	[kcal/h]	[W/W]	[Btu/Wh]	[kcal/Wh]	[W]	[A]	[kg/h]	
	-23,3	54,4	32,2	32,2	252,1	861	216,9	1,59	5,43	1,37	158,6	0,88	2,71	ASHRAE LBP
	[-10]	130	90	90										
	-25	55	32	55	190,0	649	163,5	1,25	4,26	1,07	152,2	0,84	2,48	cecomaf LBP
	[-13]	131	89,6	131										
	-35	40	20	40	136,0	464	117,0	1,19	4,06	1,02	114,3	0,65	1,65	EN12900 LBP
	[-31]	104	68	104										
	-23,3	48,9	4,44	48,9	205,5	702	176,9	1,33	4,53	1,14	155,0	0,86	3,00	ARI540 LBP
	[-10]	120	40	120										
	-23,3	40,6	32,2	32,2	271,8	928	233,9	1,83	6,24	1,57	148,7	0,83	2,92	AHAM LBP
	[-10]	105	90	90										
	-35	45	32	45	130,3	445	112,2	1,13	3,85	0,97	115,6	0,66	1,55	opt
	[-31]	113	89,6	113										

Performance tables

220V/50Hz, RSCR, static, VDE

	pe	Cooling capacity			COP	EER	P1	I	m		
	[°C]	[°F]	[W]	[Btu/h]	[kcal/h]	[W/W]	[Btu/Wh]	[kcal/Wh]	[W]	[A]	[kg/h]
[°C / °F]	-35	-31	130,3	445	112,2	1,13	3,85	0,97	115,6	0,66	1,55
cond. pressure	-30	-22	171,2	585	147,4	1,31	4,48	1,13	130,4	0,73	2,04
pc= 45/113	-25	-13	220,9	754	190,1	1,51	5,15	1,30	146,5	0,82	2,63
return gas temp.	-23,3	-10	240,0	820	206,6	1,58	5,38	1,36	152,4	0,85	2,86
RGT= 32/90	-20	-4	280,7	958	241,5	1,71	5,82	1,47	164,6	0,92	3,35
liquid temp	-15	5	351,6	1201	302,6	1,89	6,47	1,63	185,6	1,03	4,20
Tliq= 45/113	-10	14	435,1	1486	374,5	2,07	7,06	1,78	210,4	1,16	5,21
[°C / °F]	-35	-31	109,6	374	94,4	0,95	3,26	0,82	114,9	0,66	1,43
cond. pressure	-30	-22	145,9	498	125,6	1,10	3,74	0,94	133,2	0,75	1,90
pc= 55/131	-25	-13	190,0	649	163,5	1,25	4,26	1,07	152,2	0,84	2,48
return gas temp	-23,3	-10	207,0	707	178,2	1,30	4,45	1,12	159,0	0,88	2,70
RGT= 32/90	-20	-4	243,2	831	209,3	1,41	4,80	1,21	172,9	0,96	3,18
liquid temp	-15	5	306,7	1047	263,9	1,56	5,34	1,35	196,1	1,08	4,02
Tliq= 55/131	-10	14	381,7	1304	328,5	1,71	5,86	1,48	222,6	1,22	5,01

Model

Designation	NLE15KK.4	220-240V/50Hz	Conf. 4	Sales code:	105H6906
-------------	------------------	----------------------	----------------	-------------	-----------------

Configuration

Motorconfiguration	RSCR
Power supply (nominal)	220-240V/50Hz 1~
Refrigerant	R600a
Application	LBP
Voltage range	198-254V
Starting torque	LST
Approvals	VDE

Electrical accessories / wiring diagram

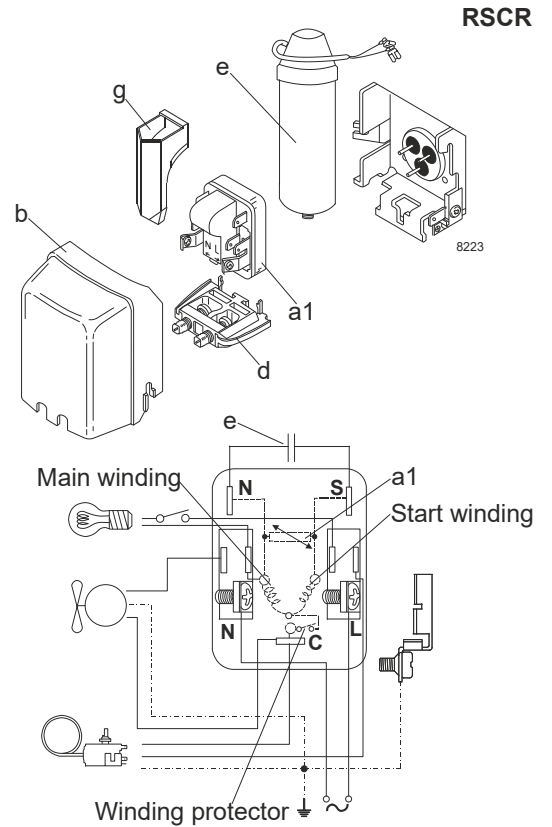

Ambient temperatures / system cooling

Ambient temperature min.:	10°C / 50°F
Ambient temperature max.:	43°C / 110°F

System cooling (n/a: outside limits)			
T ambient	LBP	MBP	HBP
32°C / 90°F	static	n/a	n/a
38°C / 100°F	static	n/a	n/a
43°C / 110°F	static	n/a	n/a

Operation pressure range

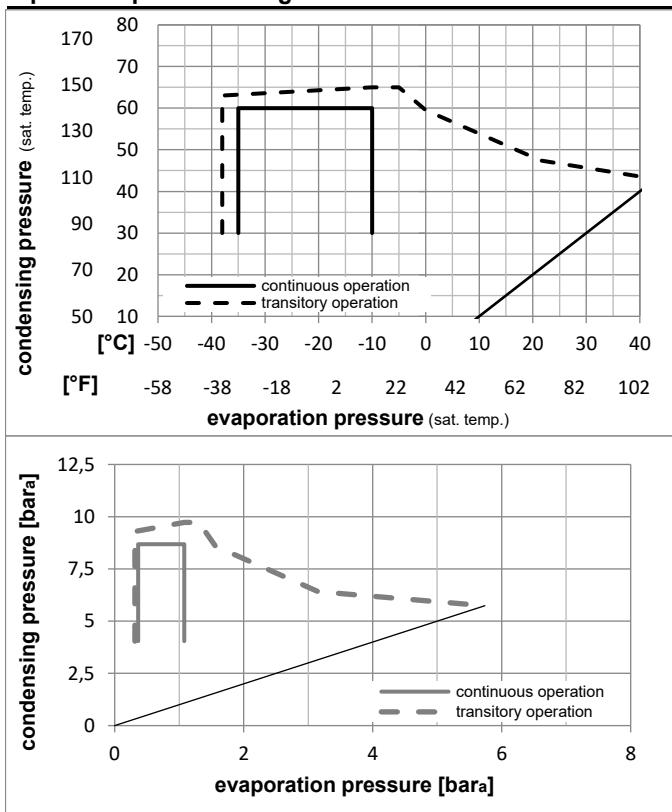

Components

a1	PTC starter (220V, 250hm, 6.3mm)	103N0016
e	run capacitor (4μF, 6.3mm)	117-7117
b	plastic cover	103N2010
d	cord relief	103N1010
g	protection screen for PTC	103N0476
	bracket for run capacitor	117-0300

Alternative components

b	plastic cover	103N2011
---	---------------	----------

Model

Designation **NLE15KK.4 220-240V/50Hz** Conf. **4** Sales code: **105H6906**

Optimization + standard conditions

220V/50Hz, RSCR, static, VDE

	Evaporating pressure (saturation temperature)				Condensing pressure (saturation temperature)						Power consumption			ASHRAE LBP
	pe	pc	RGT	Tliq	Cooling capacity			COP	EER	P1	I	Ref. mass flow		
	[°C]	[°C]	[°C]	[°C]	[W]	[Btu/h]	[kcal/h]	[W/W]	[Btu/Wh]	[kcal/Wh]	[W]	[A]	[kg/h]	
	-23,3	54,4	32,2	32,2	252,1	861	216,9	1,59	5,43	1,37	158,6	0,88	2,71	ASHRAE LBP
	[-10]	130	90	90										
	-25	55	32	55	190,0	649	163,5	1,25	4,26	1,07	152,2	0,84	2,48	cecomaf LBP
	[-13]	131	89,6	131										
	-35	40	20	40	136,0	464	117,0	1,19	4,06	1,02	114,3	0,65	1,65	EN12900 LBP
	[-31]	104	68	104										
	-23,3	48,9	4,44	48,9	205,5	702	176,9	1,33	4,53	1,14	155,0	0,86	3,00	ARI540 LBP
	[-10]	120	40	120										
	-23,3	40,6	32,2	32,2	271,8	928	233,9	1,83	6,24	1,57	148,7	0,83	2,92	AHAM LBP
	[-10]	105	90	90										
	-35	45	32	45	130,3	445	112,2	1,13	3,85	0,97	115,6	0,66	1,55	opt
	[-31]	113	89,6	113										

Performance tables

220V/50Hz, RSCR, static, VDE

	pe	Cooling capacity			COP	EER	P1	I	m		
	[°C]	[°F]	[W]	[Btu/h]	[kcal/h]	[W/W]	[Btu/Wh]	[kcal/Wh]	[W]	[A]	[kg/h]
[°C / °F]	-35	-31	130,3	445	112,2	1,13	3,85	0,97	115,6	0,66	1,55
cond. pressure	-30	-22	171,2	585	147,4	1,31	4,48	1,13	130,4	0,73	2,04
pc= 45/113	-25	-13	220,9	754	190,1	1,51	5,15	1,30	146,5	0,82	2,63
return gas temp.	-23,3	-10	240,0	820	206,6	1,58	5,38	1,36	152,4	0,85	2,86
RGT= 32/90	-20	-4	280,7	958	241,5	1,71	5,82	1,47	164,6	0,92	3,35
liquid temp	-15	5	351,6	1201	302,6	1,89	6,47	1,63	185,6	1,03	4,20
Tliq= 45/113	-10	14	435,1	1486	374,5	2,07	7,06	1,78	210,4	1,16	5,21
[°C / °F]	-35	-31	109,6	374	94,4	0,95	3,26	0,82	114,9	0,66	1,43
cond. pressure	-30	-22	145,9	498	125,6	1,10	3,74	0,94	133,2	0,75	1,90
pc= 55/131	-25	-13	190,0	649	163,5	1,25	4,26	1,07	152,2	0,84	2,48
return gas temp	-23,3	-10	207,0	707	178,2	1,30	4,45	1,12	159,0	0,88	2,70
RGT= 32/90	-20	-4	243,2	831	209,3	1,41	4,80	1,21	172,9	0,96	3,18
liquid temp	-15	5	306,7	1047	263,9	1,56	5,34	1,35	196,1	1,08	4,02
Tliq= 55/131	-10	14	381,7	1304	328,5	1,71	5,86	1,48	222,6	1,22	5,01