

Model

Designation	NLV8.0CN	Sales code:	105H7813
-------------	-----------------	-------------	-----------------

Compressor design

Oil type	Polyolester	Refrigerant(s)	R290
Oil viscosity	32cST	Displacement	7,96cm ³ / 0,49cu.in
Oil quantity	298cm ³ / 10,1fl.oz	Compressors on pallet	80
Refr. charge - tech. limit	200g / 7,1oz		
Free gas volume comp.	2360cm ³ / 79,8fl.oz		
Weight	10,8kg / 23,8lbs		
Motor protection	2# internal		
Winding resist. ph. to ph.	5,3Ω (at 25°C)		
Max. winding temp.	125°C / 257°F		
Max. discharge temp.	130°C / 266°F		



General - Configurations and Applications with NLV8.0CN and Controller

	Conf. 1
Sales code single pack:	105N4120
Sales code industry pack:	105N4121
Power supply (nominal)	220-240V 50/60Hz
Approvals	CCC
Refrigerant	R290
Number of phases	1~ AC
Application	LBP+MBP
Starting torque	HST
Hot gas defrost	OK
Long interval pull down	OK
System cooling	fan 3m/s
Note	- / -

Controller functions

	Conf. 1
Protection	Mechanic
Max output power	1000 W
No of relays	0
Hot gas defrost	yes
AEO speed setting	yes
Serial speed setting	yes
DWI / Frequency input	yes
Note	

Model

Designation **NLV8.0CN**

Sales code: **105H7813**

Compressor dimensions

Housing	A Height	218,5mm / 8,6in
	B Height	212,5mm / 8,37in
	C Length shell	205mm / 8,07in
	D Length w. cover	252mm / 9,92in
	E Width	166mm / 6,54in

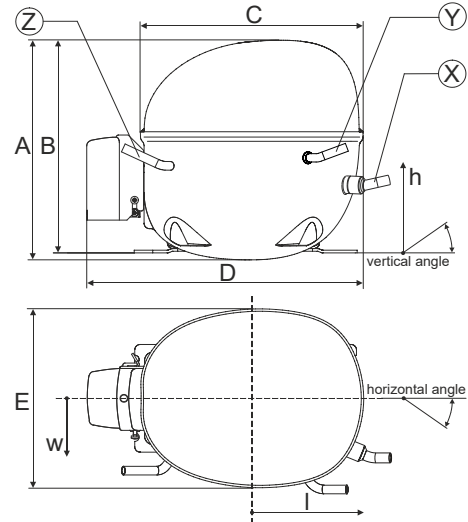

Connectors		Suction	Discharge	Process
		X	Y	Z
Diameter	[mm]	øi 8,11-8,29	øi 6,11-6,29	øi 6,11-6,29
	(i:inside, o:outside) [in]	øi 0,32-0,33	øi 0,24-0,25	øi 0,24-0,25
Material		copper	copper	copper
Horizontal angle	±2°	0°	0°	0°
Vertical angle	±2°	15°	21°	155°
Position l/h/w	[mm]	132/69/56	94/99/86	-111/92/72
	[in]	5,2/2,7/2,2	3,7/3,9/3,4	-4,4/3,6/2,8
Straight tube l.	[mm]	12	12	12
	[in]	0,5	0,5	0,5

Compressor fixation

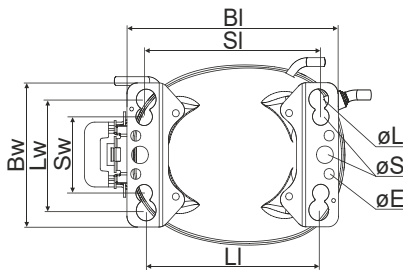

Baseplate	[mm]	[inch]
BI	204	8.03
Bw	132	5.2
øE	ø 9.7	ø 0.38

Large holes	[mm]	[inch]
LI	165	6.5
LW	101.6	4
øL	ø 19	ø 0.75

Small holes	[mm]	[inch]
SI	170	6.7
SW	70	2.76
øS	ø 16	ø 0.63

Bolt joint

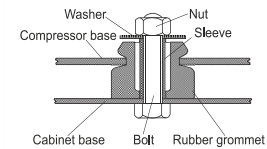

Snap-on

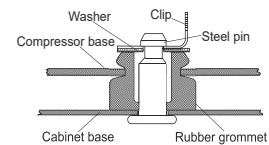

Mounting accessories	one comp.	multi pack
Bolt joint M6 ø16mm	118-1917	118-1918
Bolt joint ø1/4" ø16mm	118-1946	
Bolt joint ø1/4" ø19mm	118-1949	
Snap-on ø7,3 ø16mm	118-1947	118-1919

Application notes

Operation possible until tilted up to 3 degrees

Provision for PE Grounding is located at the PE Stamp on the compressor

Model

Designation **NLV8.0CN** **220-240V 50/60Hz** **Conf. 1** Sales code: **105H7813**

Controller **NLV Basic 230V** **105N4120**

Sales code single pack: 105N4120 (1 units)
 Sales code industry pack: 105N4121 (8 units)
 Adaption to compressor: detached
 Protection class: IP31
 Weight: 1 kg / 2.2 lbs
 Voltage nom.: 220-240V 50/60Hz
 Voltage range: 198-264 V
 Max, current: 8A
 LRA (Locked Rotor Amperage) 1,3 A
 Cable length: 680 mm
 Compressor speed range: 2000-4500 rpm

Controller dimensions:

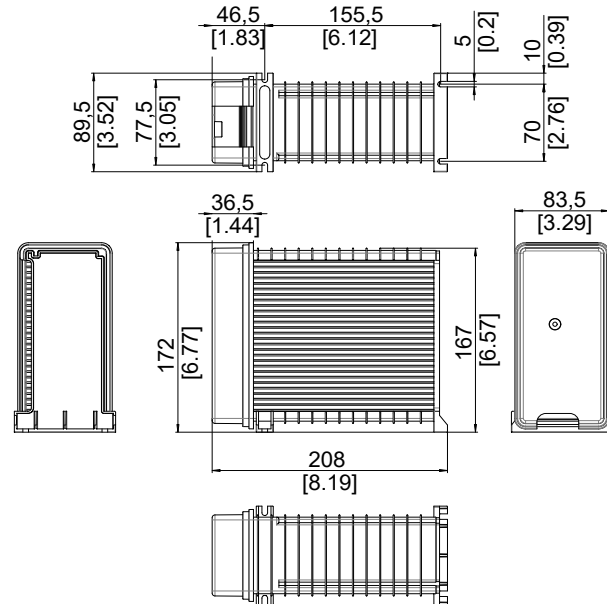

QR Code and Hyperlink leads to the [Operating Instructions.](#)

Operation Limits

System cooling

Ensure proper airflow of 3 m/s at both compressor and electronic units.
 The airflow for the electronics must be directed to the heat sink.

Ambient/ machineroom temperatures minimum /maximum

Ambient temperature range: 10 - 43°C / 50 - 110°F
 Machine room temperature range compressor: 10 - 48°C / 50 - 119°F
 Machine room temperature range controller: 10 - 50°C / 50 - 122°F

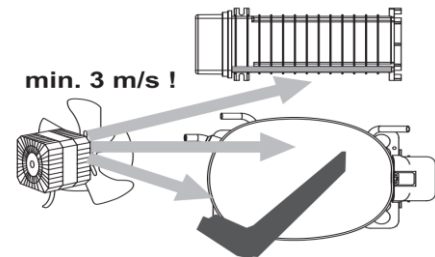

Operation pressure range

R290

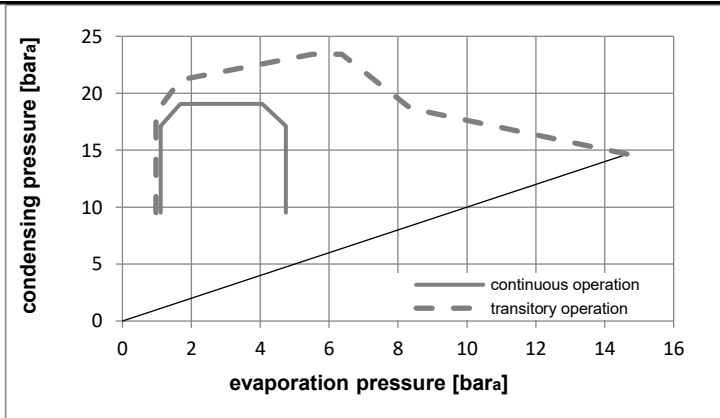
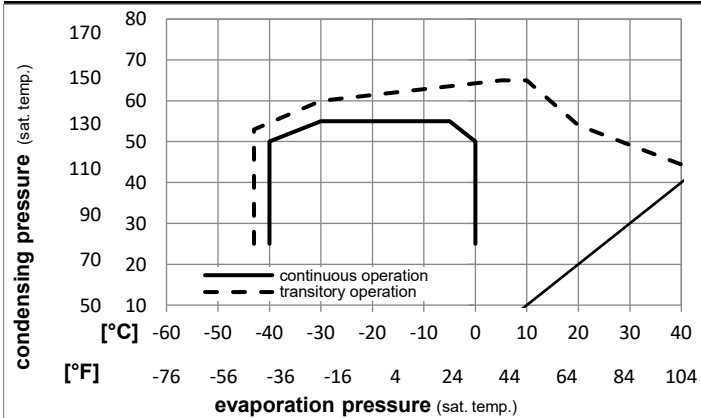

Model

Designation **NLV8.0CN** **220-240V 50/60Hz** **Conf. 1** Sales code: **105H7813**

Controller **NLV Basic 230V** **105N4120**

Controller connections

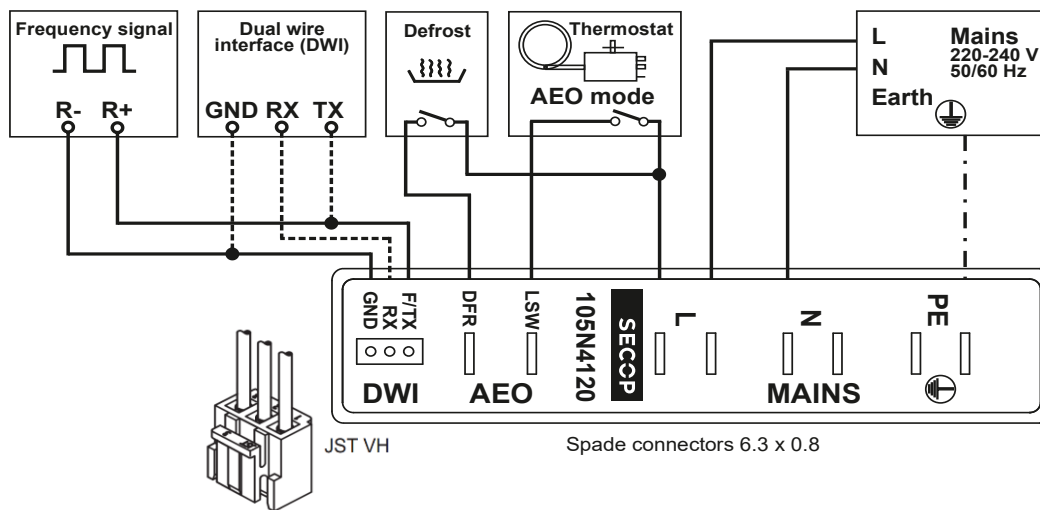
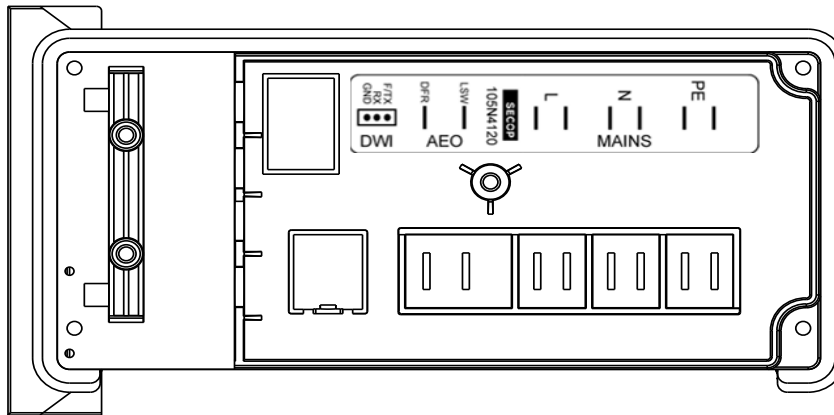

Accessories (Compressor + Controller) - check operation manual for details

103N2008	plastic cover	1 pcs
103N9110	plastic cover (MP of 103N2008)	80 pcs

Model

Designation **NLV8.0CN** **220-240V 50/60Hz** **Conf. 1** Sales code: **105H7813**

Controller **NLV Basic 230V** **105N4120**

Optimization + standard conditions

R290, 220V, 50Hz, Rpm_N 4500, fan 3m/s

	Evaporating pressure (saturation temperature)				Condensing pressure (saturation temperature)			Return gas temp.			Liquid temp.			Cooling capacity			COP	EER	Power consumption			
	pe	pc	RGT	Tliq	[W]	[Btu/h]	[kcal/h]	[W/W]	[Btu/Wh]	[kcal/Wh]	P1	I	ṁ	[W]	[A]	[kg/h]						
[°C]	-23	54	32	32	556,7	1901	479,1	1,76	5,99	1,51	317,2	2,12	5,64	ASHRAE LBP								
[°F]	-10	130	90	90																		
[°C]	-25	55	32	55	414,7	1416	356,9	1,36	4,64	1,17	305,0	2,05	5,16	cecomaf LBP								
[°F]	-13	131	90	131																		
[°C]	-35	40	20	40	316,3	1080	272,2	1,41	4,81	1,21	224,5	1,57	3,61	EN12900 LBP								
[°F]	-31	104	68	104																		
[°C]	-7	54	35	46	1050,0	3586	903,6	2,33	7,96	2,01	450,2	2,90	11,98	ASHRAE MBP								
[°F]	20	130	95	115																		
[°C]	-10	55	32	55	826,8	2824	711,6	1,94	6,64	1,67	425,5	2,75	10,46	cecomaf MBP								
[°F]	14	131	90	131																		
[°C]	-10	45	20	45	940,6	3212	809,5	2,34	7,98	2,01	402,8	2,62	11,55	EN12900 MBP								
[°F]	14	113	68	113																		

Standard conditions with different RPM

R290, 220V, 50Hz, Rpm_N 4500, fan 3m/s

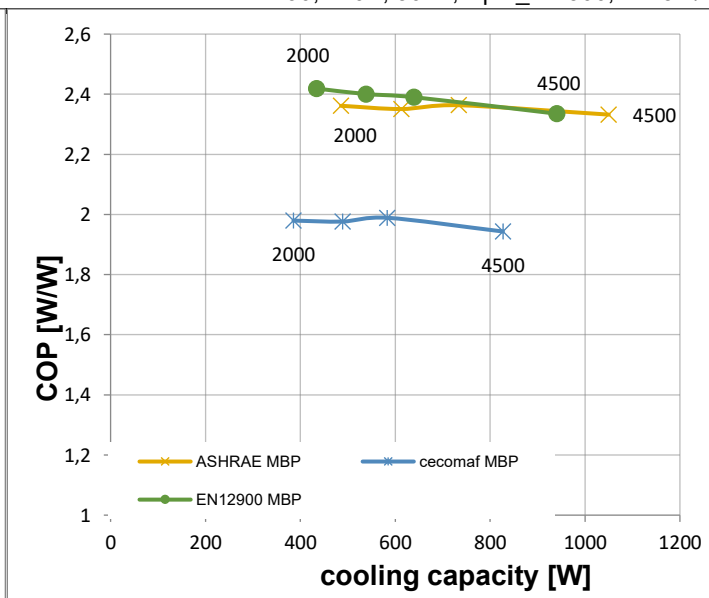
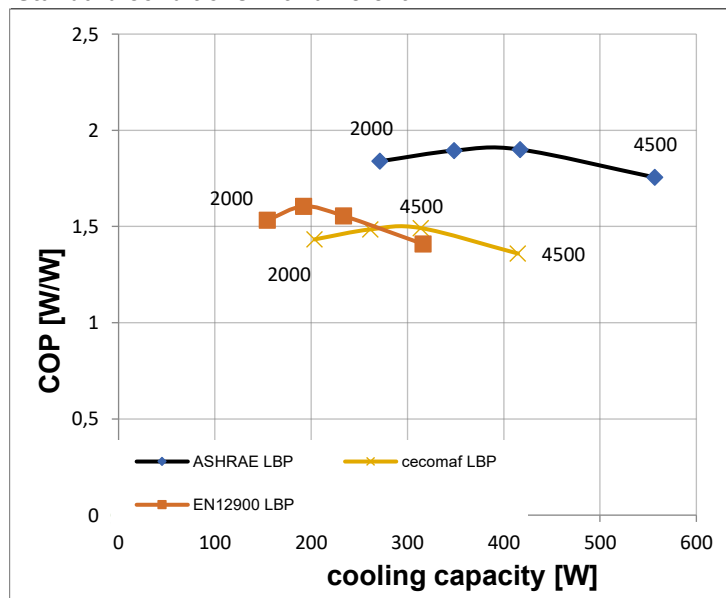

Test conditions:

	pe [°C]	pc [°C]	Tliq [°C]	Tsuc [°C]
ASHRAE LBP	-23,33	54,44	32,22	32,22
cecomaf LBP	-25	55	55	32
EN12900 LBP	-35	40	40	20

	pe [°C]	pc [°C]	Tliq [°C]	Tsuc [°C]
ASHRAE MBP	-6,66	54,44	46,11	35
cecomaf MBP	-10	55	55	32
EN12900 MBP	-10	45	45	20