

ASHRAE LBP

115V, 60Hz, static cooling, PTC consumption incl.

Evap. temp. in °F	-49	-40	-30	-20	-13	-10	0	10	14	20	30	32	40	45	50	59	68
Capacity in BTU/h					89.1	103	156	221	252	302	399	421	517	584	657	804	
Power cons. in W					49.7	50.8	55.2	60.5	63.0	66.3	72.4	74.0	78.5	81.4	84.2	88.9	
Current cons. in A					1.07	1.07	1.09	1.11	1.12	1.13	1.16	1.16	1.19	1.20	1.22	1.25	
EER in BTU/Wh					1.79	2.03	2.82	3.66	4.01	4.55	5.51	5.72	6.58	7.17	7.79	9.04	

ASHRAE HBP

115V, 60Hz, static cooling, PTC consumption incl.

Evap. temp. in °F	-49	-40	-30	-20	-13	-10	0	10	14	20	30	32	40	45	50	59	68
Capacity in BTU/h					79.2	91.6	139	197	224	268	354	375	458	517	581	711	
Power cons. in W					49.7	50.8	55.2	60.5	63.0	66.3	72.4	74.0	78.5	81.4	84.2	88.9	
Current cons. in A					1.07	1.07	1.09	1.11	1.12	1.13	1.16	1.16	1.19	1.20	1.22	1.25	
EER in BTU/Wh					1.59	1.80	2.51	3.25	3.07	4.04	4.89	5.09	5.83	6.35	6.90	7.99	

EN 12900 Household (CECOMAF)

115V, 60Hz, static cooling, PTC consumption incl.

Evap. temp. in °F	-49	-40	-30	-20	-13	-10	0	10	14	20	30	32	40	45	50	59	68
Capacity in W					21.0	24.3	36.8	52.3	59.0	71.2	94.2	99.0	122	137	154	189	
Power cons. in W					49.7	50.8	55.2	60.5	63.0	66.3	72.4	74.0	78.5	81.4	84.2	88.9	
Current cons. in A					1.07	1.07	1.09	1.11	1.12	1.13	1.16	1.16	1.19	1.20	1.22	1.25	
COP in W/W					0.42	0.48	0.67	0.86	0.95	1.07	1.30	1.35	1.55	1.69	1.83	2.12	

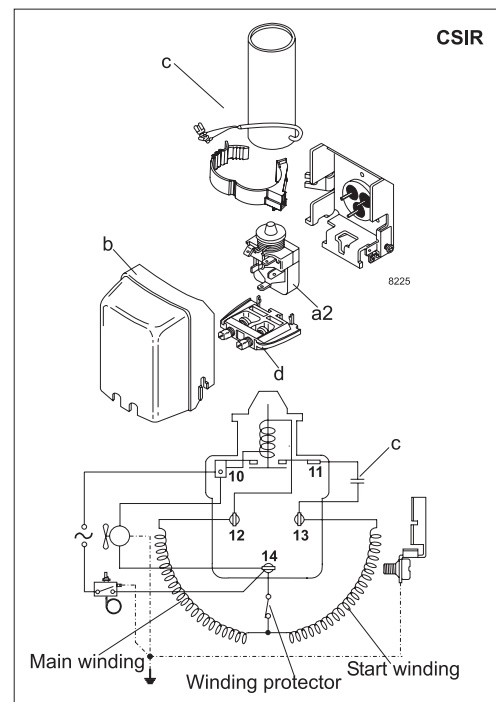
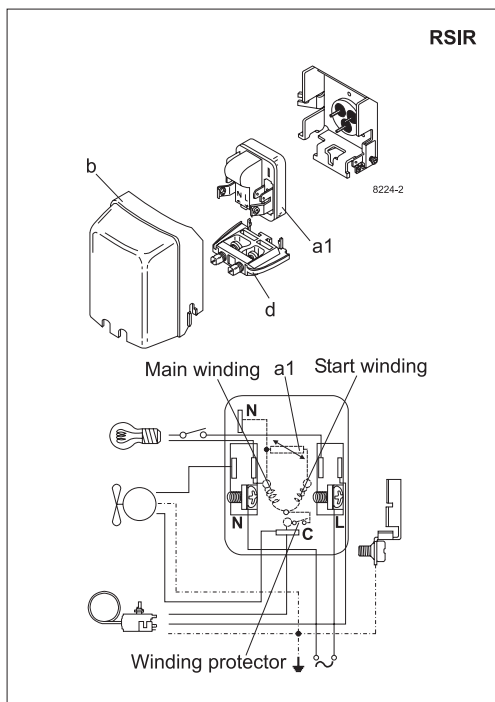

Accessories for	PL30F	Figure	Code number
PTC starting device	1/4 in. spade connect.	a1	103N0026
	3/16 in. spade connect.		103N0023
Starting relay	1/4 in. spade connect.	a2	117U6000
Cover		b	103N0492
Start. capacitor 80 µF	1/4 in. spade connect.	c	117U5015
Cord relief		d	103N1010

Test conditions	ASHRAE LBP	ASHRAE HBP	EN 12900/CECOMAF
Condensing temp.	130°F	130°F	131°F
Ambient temp.	90°F	95°F	90°F
Suction gas temp.	90°F	95°F	90°F
Liquid temperature	90°F	115°F	131°F

Mounting accessories		Code number
Bolt joint for one comp.	Ø: 5/8 in.	118-1917
Bolt joint in quantities	Ø: 5/8 in.	118-1918
Snap-on in quantities	Ø: 5/8 in.	118-1919

Secop accepts no responsibility for possible errors in catalogs, brochures, and other printed material. Secop reserves the right to alter its products without notice. This also applies to products already on order provided that such alterations can be made without substantial changes being necessary to specifications already agreed. All trademarks in this material are the property of the respective companies. Secop and the Secop logotype are trademarks of Secop GmbH. All rights reserved. www.secop.com