

SC12/12CLX LBP Twin Compressor R404A/R507 220-240V 60Hz

General

Code number	104L4034
Approvals	UL984
Compressors on pallet	18

Application

Application	LBP					
Frequency	Hz	50			60	
Evaporating temperature	°C	-			-40 to -10	
Voltage range	V	-			198 - 254	
Max. condensing temperature continuous (short)	°C	-			55 (60)	
Max. winding temperature continuous (short)	°C	-			125 (135)	

Cooling requirements

Frequency	Hz	50			60		
Application		LBP	MBP	HBP	LBP	MBP	HBP
32°C		-	-	-	F ₂	-	-
38°C		-	-	-	F ₂	-	-
43°C		-	-	-	-	-	-
Remarks on application:							

Motor

Motor type	CSIR		
LRA (rated after 4 sec. UL984) *, HST LST	A	2 x 18.6	-
Cut in Current *, HST LST	A	2 x 18.6	-
Resistance, main start winding (25°C)	Ω	3.7	14.1

* Operational current for the second compressor time-delayed.

Design

Displacement	cm ³	2 x 12.87
Oil quantity (type)	cm ³	1220 (polyolester)
Maximum refrigerant charge	g	2200
Free gas volume in compressor	cm ³	2820
Weight without electrical equipment	kg	28.0

Dimensions

Height	mm	A	259
		B	254
		B1	193
		B2	110
Suction connector (service valve)	location/I.D. mm	C	12 37°
Suction connector (solder connector)	location/I.D. mm	C	12 37°
Process connector	location/I.D. mm angle	D	6.2 37°
	material comment		Copper Rubber plug
Discharge connector	location/I.D. mm angle	E	6.2 37°
	material comment		Copper Rubber plug
Oil cooler connector	location/I.D. mm angle	F	-
	material comment		-
Connector tolerance	I.D. mm		±0.09
Remarks:			

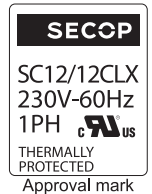
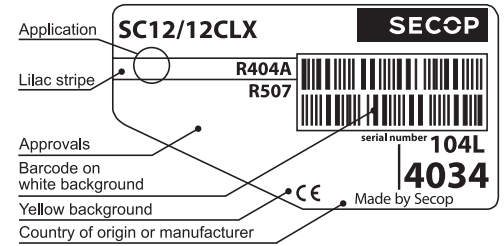

- S = Static cooling normally sufficient
- O = Oil cooling
- F₁ = Fan cooling 1.5 m/s (compressor compartment temperature equal to ambient temperature)
- F₂ = Fan cooling 3.0 m/s necessary
- SG = Suction gas cooling normally sufficient
- = not applicable in this area

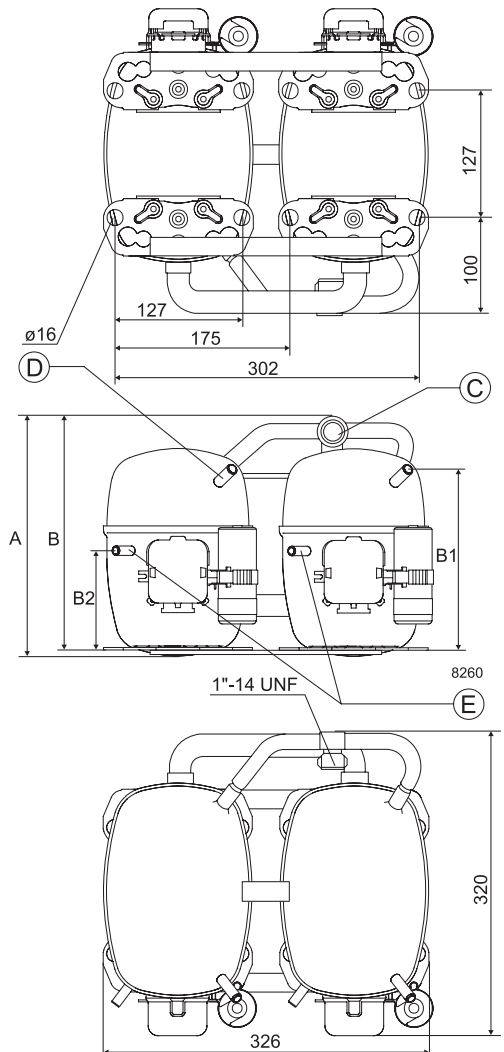

ASHRAE LBP*

230V, 60Hz, fan cooling F₂

Evap. temp. in °C	-45	-40	-35	-30	-25	-23.3	-20	-15	-10	-6.7	-5	0	5	7.2	10	15	20
Capacity in W		338	654	994	1370	1506	1788	2260	2794								
Power cons. in W		554	752	924	1080	1132	1232	1392	1568								
Current cons. in A		5.16	5.50	5.92	6.46	6.66	7.08	7.82	8.64								
COP in W/W		0.61	0.87	1.08	1.27	1.33	1.45	1.62	1.78								

EN 12900 Household (CECOMAF)*

230V, 60Hz, fan cooling F₂

Evap. temp. in °C	-45	-40	-35	-30	-25	-23.3	-20	-15	-10	-6.7	-5	0	5	7.2	10	15	20
Capacity in W		292	564	858	1180	1298	1540	1944	2400								
Power cons. in W		554	752	924	1080	1132	1232	1392	1568								
Current cons. in A		5.16	5.50	5.92	6.46	6.66	7.08	7.82	8.64								
COP in W/W		0.53	0.75	0.93	1.09	1.15	1.25	1.40	1.53								

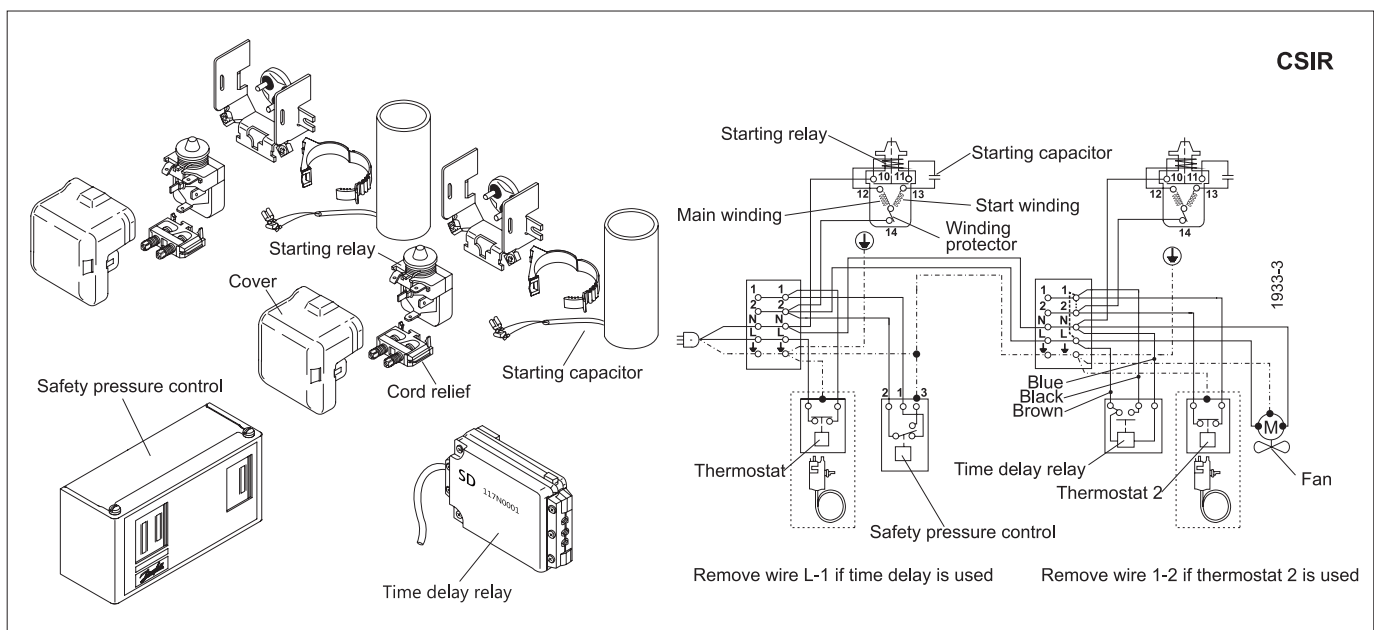

Accessories	SC12/12CLX	pcs.	Code number
Starting device	470 mm cable length		-
	550 mm cable length	2	-
	650 mm cable length		-
Starting relay	6.3 mm spade connectors	2	117U6019
Start. capacitor 80 µF	6.3 mm spade connectors	2	117U5017
Cover		2	103N2009
Cord relief		2	103N1004
Time-delay relay		1	117N0001
Check valve (to be used with time-delay relay)		2	020-1014
Service valve	12 mm	1	118-7350
Solder connector (alternative)	12 mm	1	104B0584
Service valve	16 mm	1	-
Solder connector (alternative)	16 mm	1	-
Seal ring for service valve and solder connector		1	118-3638

Test conditions	EN 12900/CECOMAF*	ASHRAE LBP*
Condensing temperature	45°C	45°C
Ambient temperature	32°C	32°C
Suction gas temperature	32°C	32°C
Liquid temperature	no subcooling	32°C

Mounting accessories		pcs.	Code number
Bolt joint for one compressor	Ø: 16 mm	2	118-1917
Bolt joint in quantities	Ø: 16 mm	2	118-1918

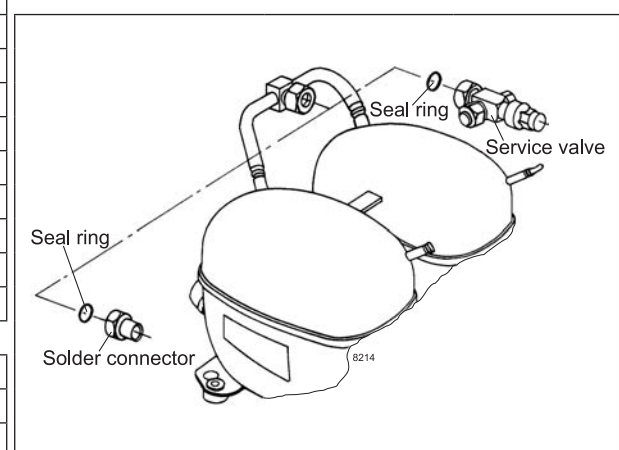

Secop accepts no responsibility for possible errors in catalogs, brochures, and other printed material. Secop reserves the right to alter its products without notice. This also applies to products already on order provided that such alterations can be made without substantial changes being necessary to specifications already agreed. All trademarks in this material are the property of the respective companies. Secop and the Secop logotype are trademarks of Secop GmbH. All rights reserved. www.secop.com