

Model

Designation	SC12CLX.2	115V/60Hz 1~	Sales code:	104L1696
-------------	------------------	--------------	-------------	-----------------

Compressor design

Oil type	Polyolester	Refrigerant(s)	R404A, R452A, R507
Oil viscosity	32cSt	Displacement	12,87cm ³ / 0,79cu.in
Oil quantity	500cm ³ / 16,9fl.oz	Compressors on pallet	80
Refr. charge - tech. limit	1300g / 45,9oz		
Free gas volume comp.	1510cm ³ / 51,1fl.oz		
Weight	13,2kg / 29,1lbs		
Motor protection	1# internal		
Winding resistance main	0,98Ω (at 25°C)		
Winding resistance aux	4,18Ω (at 25°C)		
Max. winding temp.	125°C / 257°F		
Max. discharge temp.	130°C / 266°F		



General - Configurations with SC12CLX.2

	Conf. 1	Conf. 2
Motorconfiguration	CSIR	CSIR
Power supply (nominal)	115V/60Hz	115V/60Hz
Number of phases	1	1
Voltage range	103-127V	103-127V
Approvals	UL	UL
Starting torque	HST	HST
Note	- / -	

Applications with SC12CLX.2

	Conf. 1	Conf. 2
Refrigerant	R404A	R452A
Application	LBP	LBP
System cooling	fan 3m/s	fan 3m/s
Hot gas defrost	OK	OK
Long interval pull down	OK	OK

Electrical data - Configurations with SC12CLX.2

	Conf. 1	Conf. 2
Starting device type	relay	relay
Run capacitor	-/-	-/-
Start capacitor	240μF	240μF
LRA (locked rotor amps / 4s)	39,7A	39,7A
RLA (rated load amps / 1s)	7,6A	7,6A
Cut in current	39,7A	39,7A
IP class	21	21

Model

Designation	SC12CLX.2	115V/60Hz 1~	Sales code:	104L1696
-------------	------------------	--------------	-------------	-----------------

Compressor dimensions

Housing	A Height	209mm / 8,23in
	B Height	203mm / 7,99in
	C Length shell	218mm / 8,58in
	D Length w. cover	255mm / 10,04in
	E Width	151mm / 5,94in

Connectors		Suction	Discharge	Process
		X	Y	Z
Diameter	[mm]	øi 8,11-8,29	øi 6,41-6,59	øi 6,41-6,59
(i:inside, o:outside)	[in]	øi 0,32-0,33	øi 0,25-0,26	øi 0,25-0,26
Material		copper	copper	copper
Horizontal angle	±2°	37°	37°	143°
Vertical angle	±2°	30°	0°	150°
Position l/h/w	[mm]	107/183/55	115/100/63	-107/183/55
	[in]	4,2/7,2/2,2	4,5/3,9/2,5	-4,2/7,2/2,2
Straight tube l.	[mm]	12	12	12
	[in]	0,5	0,5	0,5

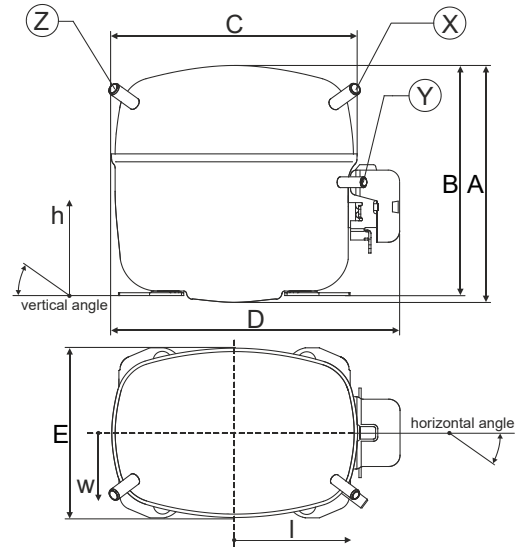

Compressor fixation

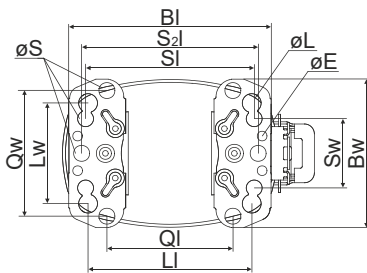

Baseplate	[mm]	[inch]
BI	204	8.03
Bw	150	5.9
øE	ø 9.7	ø 0.38
Large holes		
LI	165	6.5
LW	101.6	4
øL	ø 19	ø 0.75
Small holes		
SI	170	6.7
Sw	70	2.76
øS	ø 16	ø 0.63
QI	127	5
Qw	127	5

Bolt joint

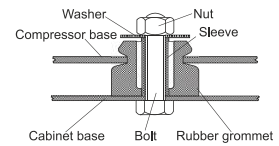

Snap-on

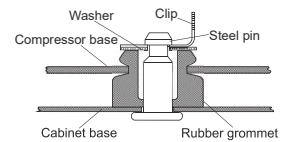

Mounting accessories

	one comp.	multi pack
Bolt joint M6 ø16mm	118-1917	118-1918
Bolt joint ø1/4" ø16mm	118-1946	
Bolt joint ø1/4" ø19mm	118-1949	
Snap-on ø7,3 ø16mm	118-1947	118-1919

Application notes

LRA value on compressor label and datasheet may differ due to different test conditions for UL approval.

Model

Designation **SC12CLX.2 115V/60Hz** Conf. 1 Sales code: **104L1696**

Configuration

Motorconfiguration CSIR
 Power supply (nominal) 115V/60Hz 1~
 Refrigerant R404A
 Application LBP
 Voltage range 103-127V
 Starting torque HST
 Approvals UL

Electrical accessories / wiring diagram

CSIR

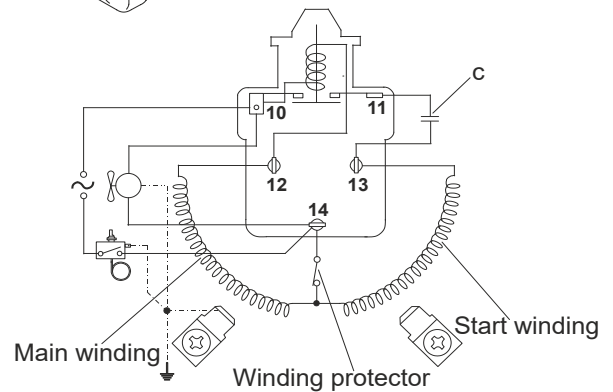
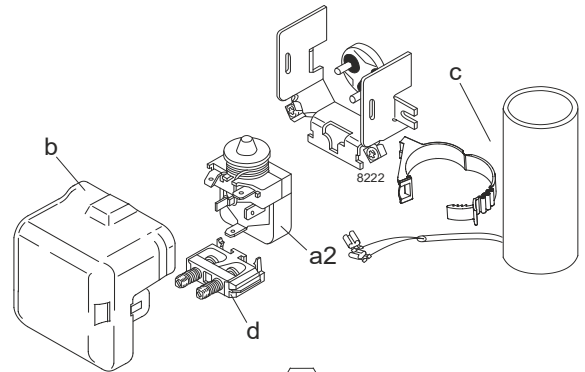

Ambient temperatures / system cooling

Ambient temperature min.: 10°C / 50°F
 Ambient temperature max.: 43°C / 110°F

System cooling (n/a: outside limits)			
T ambient	LBP	MBP	HBP
32°C / 90°F	fan 3m/s	n/a	n/a
38°C / 100°F	fan 3m/s	n/a	n/a
43°C / 110°F	fan 3m/s	n/a	n/a

Operation pressure range

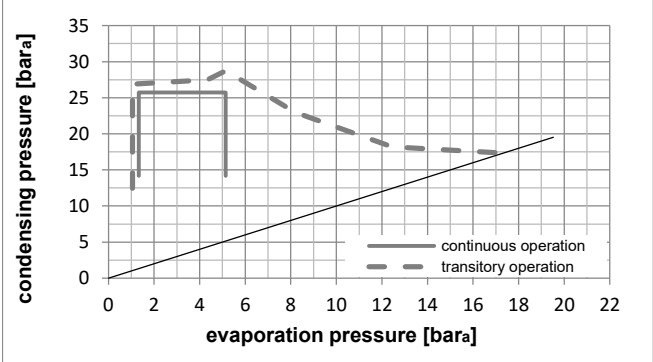
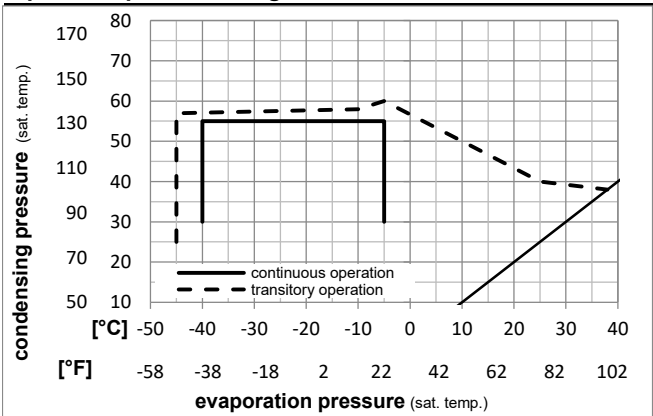

Components

a2	relay	117U6020
c	start capacitor (240µF)	117U5023
d	cord relief	103N1004
b	plastic cover	103N2008

Alternative components

a2	relay	117U6020
c	start capacitor (240µF, 15kOhm)	117U5034
d	cord relief	103N1004
b	plastic cover	103N2008

Model

Designation **SC12CLX.2 115V/60Hz** Conf. 1 Sales code: **104L1696**

Optimization + standard conditions

115V/60Hz, CSIR, fan 3m/s, UL

Evaporating pressure (saturation temperature)					Condensing pressure (saturation temperature)						Power consumption				ASHRAE LBP
					Return gas temp.						Current consumption				
					Liquid temp.						Ref. mass flow				
					Cooling capacity						COP EER				
	pe	pc	RGT	Tliq	[W]	[Btu/h]	[kcal/h]	[W/W]	[Btu/Wh]	[kcal/Wh]	P1	I	m		
[°C]	[°C]	[°C]	[°C]	[°C]							[W]	[A]	[kg/h]		
[°F]	-23,3	54,4	32,2	32,2	723,4	2471	622,6	1,14	3,89	0,98	634,4	7,20	16,86		
	-10	130	90	90											
[°C]	-25	55	32	55	485,9	1659	418,1	0,80	2,75	0,69	604,1	7,00	15,18	cecomaf LBP	
[°F]	-13	131	89,6	131											
[°C]	-35	40	20	40	371,8	1270	319,9	0,84	2,86	0,72	444,0	6,10	10,10	EN12900 LBP	
[°F]	-31	104	68	104											
[°C]	-23,3	48,9	4,44	48,9	537,8	1837	462,8	0,86	2,93	0,74	627,0	7,16	19,04	ARI540 LBP	
[°F]	-10	120	40	120											
[°C]	-23,3	40,6	32,2	32,2	812,5	2775	699,2	1,33	4,53	1,14	613,2	7,09	18,93	AHAM LBP	
[°F]	-10	105	90	90											
[°C]	-35	45	32	45	334,2	1141	287,6	0,77	2,62	0,66	435,0	6,03	8,93	opt	
[°F]	-31	113	89,6	113											

Performance tables

115V/60Hz, CSIR, fan 3m/s, UL

	pe		Cooling capacity			COP		EER		P1	I	m
	[°C]	[°F]	[W]	[Btu/h]	[kcal/h]	[W/W]	[Btu/Wh]	[kcal/Wh]	[W]	[A]	[kg/h]	
[°C / °F]	-40	-40	214,3	732	184,4	0,62	2,12	0,53	345,6	5,66	5,71	
cond. pressure	-34,4	-30	348,4	1190	299,8	0,78	2,68	0,67	444,4	6,08	9,32	
pc= 45/113	-28,9	-20	501,7	1713	431,7	0,94	3,21	0,81	534,6	6,57	13,48	
return gas temp.	-23,3	-10	678,5	2317	583,9	1,09	3,73	0,94	621,2	7,12	18,33	
RGT= 32/90	-20,6	-5	777,0	2654	668,7	1,17	3,99	1,01	664,8	7,43	21,07	
liquid temp	-15	5	997,2	3406	858,2	1,32	4,51	1,14	755,7	8,10	27,24	
Tliq= 45/113	-5	23	1483,0	5065	1276,3	1,57	5,36	1,35	945,3	9,48	41,23	
[°C / °F]	-40	-40	108,5	370	93,3	0,38	1,29	0,33	286,7	5,43	3,34	
cond. pressure	-34,4	-30	235,9	806	203,0	0,57	1,94	0,49	415,2	5,95	7,30	
pc= 55/131	-28,9	-20	376,8	1287	324,3	0,71	2,43	0,61	529,6	6,54	11,72	
return gas temp	-23,3	-10	535,6	1829	461,0	0,84	2,88	0,73	635,1	7,21	16,78	
RGT= 32/90	-20,6	-5	623,1	2128	536,3	0,91	3,10	0,78	686,1	7,56	19,59	
liquid temp	-15	5	816,9	2790	703,0	1,04	3,54	0,89	787,6	8,34	25,91	
Tliq= 55/131	-5	23	1240,8	4238	1067,9	1,26	4,31	1,09	982,6	9,91	40,16	

Model

Designation **SC12CLX.2 115V/60Hz** Conf. 2 Sales code: **104L1696**

Configuration

Motorconfiguration CSIR
 Power supply (nominal) 115V/60Hz 1~
 Refrigerant R452A
 Application LBP
 Voltage range 103-127V
 Starting torque HST
 Approvals UL

Electrical accessories / wiring diagram

CSIR

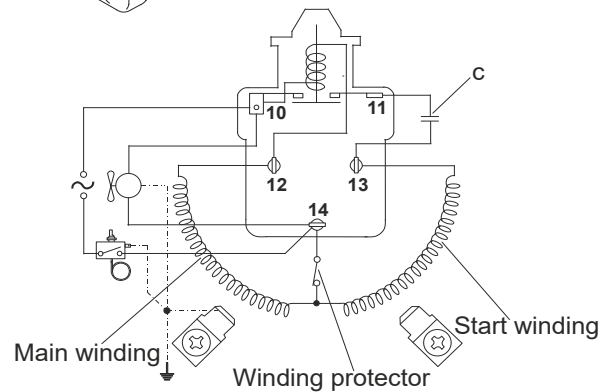
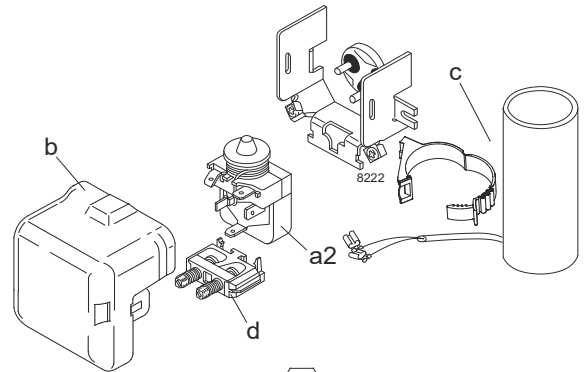

Ambient temperatures / system cooling

Ambient temperature min.: 10°C / 50°F
 Ambient temperature max.: 43°C / 110°F

System cooling (n/a: outside limits)			
T ambient	LBP	MBP	HBP
32°C / 90°F	fan 3m/s	n/a	n/a
38°C / 100°F	fan 3m/s	n/a	n/a
43°C / 110°F	fan 3m/s	n/a	n/a

Operation pressure range

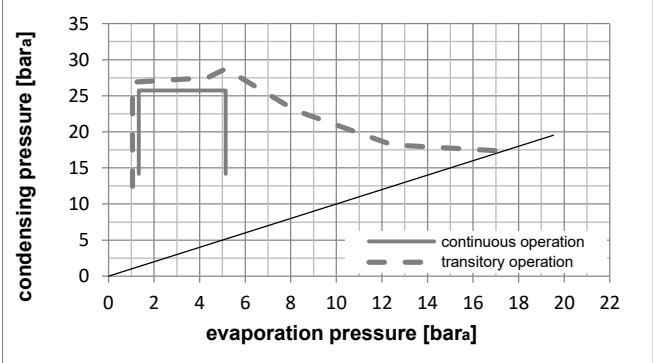
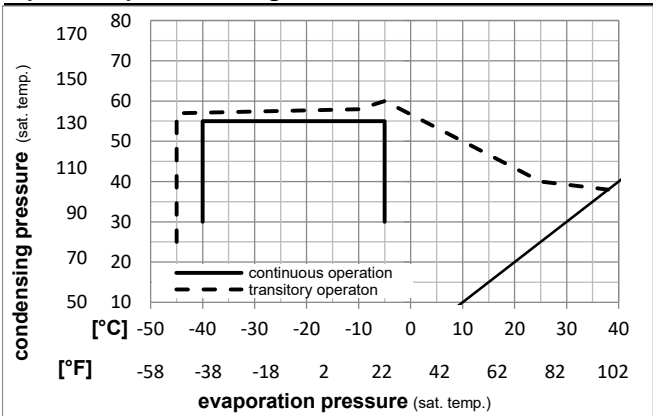

Components

- a2 relay 117U6020
- c start capacitor (240µF) 117U5023
- d cord relief 103N1004
- b plastic cover 103N2008

Alternative components

- a2 relay 117U6020
- c start capacitor (240µF, 15kOhm) 117U5034
- d cord relief 103N1004
- b plastic cover 103N2008

Model

Designation **SC12CLX.2 115V/60Hz** Conf. 2 Sales code: **104L1696**

Optimization + standard conditions

115V/60Hz, CSIR, fan 3m/s, UL

Evaporating pressure (saturation temperature)														
Condensing pressure (saturation temperature)														
Return gas temp.														
Liquid temp.														
Cooling capacity														
COP														
EER														
Power consumption														
Current consumption														
Ref. mass flow														
	pe	pc	RGT	Tliq	[W]	[Btu/h]	[kcal/h]	[W/W]	[Btu/Wh]	[kcal/Wh]	P1	I	m	
[°C]	[°C]	[°C]	[°C]	[°C]							[W]	[A]	[kg/h]	
[°F]	-23,3	54,4	32,2	32,2	661,5	2259	569,3	1,13	3,85	0,97	587,2	6,99	15,90	ASHRAE LBP
[°F]	-10	130	90	90										
[°C]	-25	55	32	55	447,9	1530	385,4	0,80	2,74	0,69	557,4	6,79	14,25	cecomaf LBP
[°F]	-13	131	89,6	131										
[°C]	-35	40	20	40	335,2	1145	288,5	0,83	2,82	0,71	405,8	5,76	9,36	EN12900 LBP
[°F]	-31	104	68	104										
[°C]	-23,3	48,9	4,44	48,9	499,6	1706	430,0	0,86	2,93	0,74	581,8	6,95	17,96	ARI540 LBP
[°F]	-10	120	40	120										
[°C]	-23,3	40,6	32,2	32,2	747,8	2554	643,5	1,31	4,48	1,13	570,2	6,87	17,97	AHAM LBP
[°F]	-10	105	90	90										
[°C]	-35	45	32	45	300,2	1025	258,4	0,76	2,59	0,65	396,2	5,69	8,24	opt
[°F]	-31	113	89,6	113										

Performance tables

115V/60Hz, CSIR, fan 3m/s, UL

	pe	Cooling capacity			COP	EER	P1	I	m			
		[°C]	[°F]	[W]						[Btu/h]	[kcal/h]	[W/W]
[°C / °F]	-40	-40		187,8	642	161,7	0,60	2,06	0,52	310,9	5,11	5,14
cond. pressure	-34,4	-30		313,6	1071	269,9	0,77	2,64	0,67	405,2	5,75	8,61
pc= 45/113	-28,9	-20		458,4	1566	394,5	0,93	3,18	0,80	492,4	6,35	12,64
return gas temp.	-23,3	-10		626,9	2141	539,5	1,09	3,71	0,93	577,1	6,92	17,37
RGT= 32/90	-20,6	-5		721,5	2464	620,9	1,16	3,97	1,00	619,9	7,21	20,05
liquid temp	-15	5		934,0	3190	803,8	1,32	4,50	1,13	709,4	7,82	26,13
Tliq= 45/113	-5	23		1408,2	4809	1211,9	1,57	5,37	1,35	896,1	9,09	40,01
[°C / °F]	-40	-40		91,0	311	78,3	0,36	1,23	0,31	252,6	4,71	2,86
cond. pressure	-34,4	-30		210,4	719	181,1	0,56	1,92	0,48	374,8	5,55	6,64
pc= 55/131	-28,9	-20		343,8	1174	295,9	0,71	2,42	0,61	485,0	6,29	10,90
return gas temp	-23,3	-10		495,6	1693	426,6	0,84	2,88	0,73	587,7	6,99	15,80
RGT= 32/90	-20,6	-5		579,9	1981	499,1	0,91	3,11	0,78	637,7	7,33	18,55
liquid temp	-15	5		768,1	2623	661,0	1,04	3,56	0,90	737,9	8,01	24,76
Tliq= 55/131	-5	23		1185,2	4048	1020,0	1,27	4,35	1,10	931,3	9,33	38,90