

Model

Designation	SC15CLX.2	115V/60Hz 1~	Sales code:	104L1853
-------------	------------------	--------------	-------------	-----------------

Compressor design

Oil type	Polyolester	Refrigerant(s)	R404A, R452A, R507
Oil viscosity	32cST	Displacement	15,28cm ³ / 0,93cu.in
Oil quantity	500cm ³ / 16,9fl.oz	Compressors on pallet	80
Refr. charge - tech. limit	1300g / 45,9oz		
Free gas volume comp.	1460cm ³ / 49,4fl.oz		
Weight	13,7kg / 30,2lbs		
Motor protection	external		
Winding resistance main	0,66Ω (at 25°C)		
Winding resistance aux	2,7Ω (at 25°C)		
Max. winding temp.	125°C / 257°F		
Max. discharge temp.	130°C / 266°F		



General - Configurations with SC15CLX.2

	Conf. 1	Conf. 2	Conf. 3	Conf. 4
Motorconfiguration	CSIR	CSCR	CSIR	CSCR
Power supply (nominal)	115V/60Hz	115V/60Hz	115V/60Hz	115V/60Hz
Number of phases	1	1	1	1
Voltage range	103-127V	103-127V	103-127V	103-127V
Approvals	UL	UL	UL	UL
Starting torque	HST	HST	HST	HST
Note	Protector and cover are included and pre-assembled to compressor.			

Applications with SC15CLX.2

	Conf. 1	Conf. 2	Conf. 3	Conf. 4
Refrigerant	R404A	R404A	R452A	R452A
Application	LBP	LBP	LBP	LBP
System cooling	fan 3m/s	fan 3m/s	fan 3m/s	fan 3m/s
Hot gas defrost	OK	OK	OK	OK
Long interval pull down	-/-	-/-	-/-	-/-

Electrical data - Configurations with SC15CLX.2

	Conf. 1	Conf. 2	Conf. 3	Conf. 4
Starting device type	relay	relay	relay	relay
Run capacitor	-/-	23,5μF	-/-	23,5μF
Start capacitor	410μF	410μF	410μF	410μF
LRA (locked rotor amps / 4s)	56,8A	54,2A	56,8A	54,2A
RLA (rated load amps / 1s)	9,8A	8,8A	9,8A	8,8A
Cut in current	56,8A	54,2A	56,8A	54,2A
IP class	21	21	21	21

Model

Designation	SC15CLX.2	115V/60Hz 1~	Sales code:	104L1853
-------------	------------------	--------------	-------------	-----------------

Compressor dimensions

Housing	A Height	219mm / 8,62in
	B Height	213mm / 8,39in
	C Length shell	218mm / 8,58in
	D Length w. cover	255mm / 10,04in
	E Width	151mm / 5,94in

Connectors		Suction	Discharge	Process
		X	Y	Z
Diameter	[mm]	øi 9,54-9,72	øi 6,41-6,59	øi 6,41-6,59
(i:inside, o:outside)	[in]	øi 0,38-0,38	øi 0,25-0,26	øi 0,25-0,26
Material		copper	copper	copper
Horizontal angle	±2°	37°	37°	143°
Vertical angle	±2°	30°	0°	150°
Position l/h/w	[mm]	107/193/55	115/110/63	-107/193/55
	[in]	4,2/7,6/2,2	4,5/4,3/2,5	-4,2/7,6/2,2
Straight tube l.	[mm]	12	12	12
	[in]	0,5	0,5	0,5

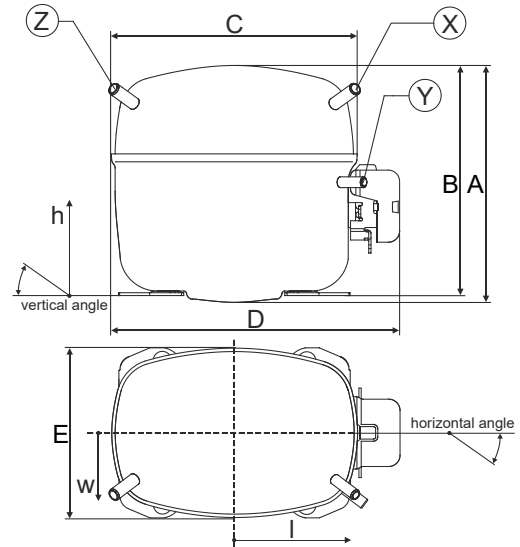

Compressor fixation

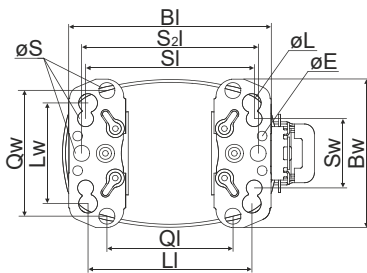

Baseplate	[mm]	[inch]
BI	204	8.03
BW	150	5.9
øE	ø 9.7	ø 0.38
Large holes		
LI	165	6.5
LW	101.6	4
øL	ø 19	ø 0.75
Small holes		
SI	170	6.7
SW	70	2.76
øS	ø 16	ø 0.63
QI	127	5
QW	127	5

Bolt joint

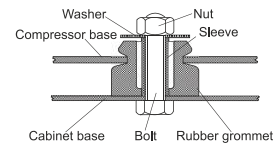

Snap-on

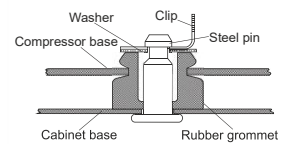

Mounting accessories

	one comp.	multi pack
Bolt joint M6 ø16mm	118-1917	118-1918
Bolt joint ø1/4" ø16mm	118-1946	
Bolt joint ø1/4" ø19mm	118-1949	
Snap-on ø7,3 ø16mm	118-1947	118-1919

Application notes

LRA value on compressor label and datasheet may differ due to different test conditions for UL approval.

Model

Designation **SC15CLX.2 115V/60Hz** Conf. 1 Sales code: **104L1853**

Configuration

Motorconfiguration CSIR
 Power supply (nominal) 115V/60Hz 1~
 Refrigerant R404A
 Application LBP
 Voltage range 103-127V
 Starting torque HST
 Approvals UL

Electrical accessories / wiring diagram

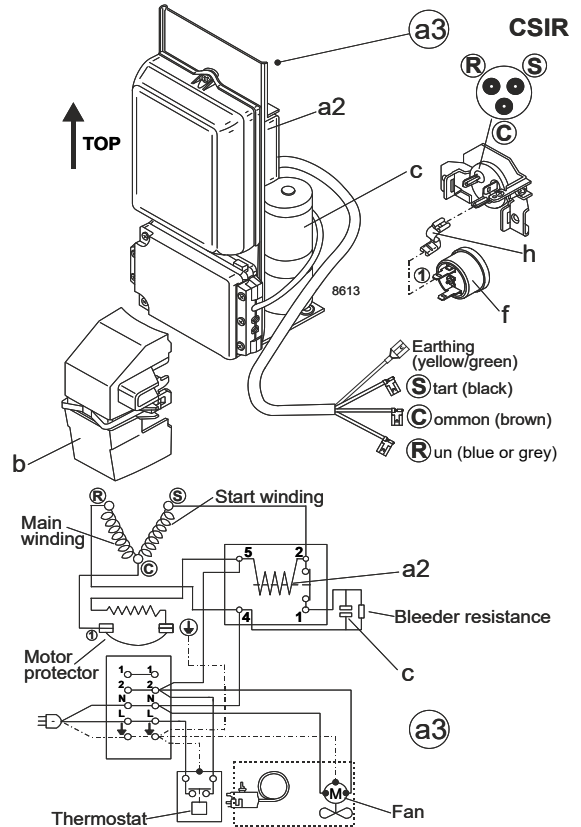

Ambient temperatures / system cooling

Ambient temperature min.: 10°C / 50°F
 Ambient temperature max.: 43°C / 110°F

System cooling (n/a: outside limits)			
T ambient	LBP	MBP	HBP
32°C / 90°F	fan 3m/s	n/a	n/a
38°C / 100°F	fan 3m/s	n/a	n/a
43°C / 110°F	fan 3m/s	n/a	n/a

Operation pressure range

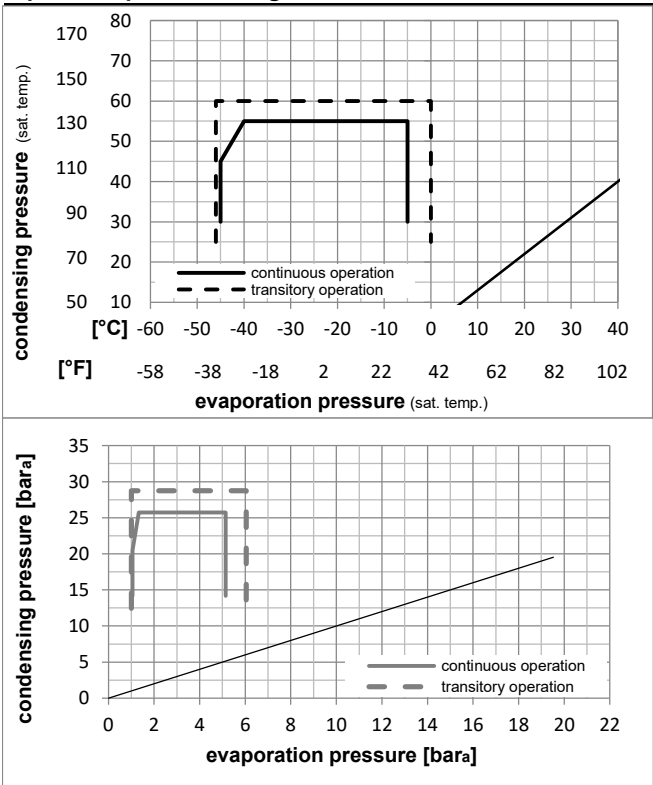

Components (protector + ~holder + cover: pre assembled)

- a3 SC starter kit 117-7053
- f ext. protector (T0761/46) 117U3212
- h protector holder 117U0439
- b plastic cover 117U1021

Alternative comp. (protector + ~holder + cover: pre assemb.)

- a2 potential relay (RVA 7AA3R) 117-7441
- c start capacitor 117U5042
- f ext. protector (T0761/46) 117U3212
- h protector holder 117U0439
- b plastic cover 117U1021

Model

Designation **SC15CLX.2 115V/60Hz** Conf. 1 Sales code: **104L1853**

Optimization + standard conditions

115V/60Hz, CSIR, fan 3m/s, UL

Evaporating pressure (saturation temperature)				Condensing pressure (saturation temperature)				Power consumption				ASHRAE LBP		
Return gas temp.				Liquid temp.				Current consumption					Ref. mass flow	
Cooling capacity				COP		EER		P1		I				
pe	pc	RGT	Tliq	[W]	[Btu/h]	[kcal/h]	[W/W]	[Btu/Wh]	[kcal/Wh]	[W]	[A]		[kg/h]	
[°C]	-23,3	54,4	32,2	32,2	880,0	3005	757,4	1,21	4,12	1,04	729,0	9,23	20,51	ASHRAE LBP
[°F]	-10	130	90	90										
[°C]	-25	55	32	55	592,4	2023	509,8	0,85	2,89	0,73	699,9	9,05	18,51	cecomaf LBP
[°F]	-13	131	89,6	131										
[°C]	-35	40	20	40	478,1	1633	411,4	0,93	3,18	0,80	512,7	7,99	12,99	EN12900 LBP
[°F]	-31	104	68	104										
[°C]	-23,3	48,9	4,44	48,9	664,9	2271	572,2	0,93	3,19	0,80	711,1	9,17	23,54	ARI540 LBP
[°F]	-10	120	40	120										
[°C]	-23,3	40,6	32,2	32,2	1017,4	3475	875,6	1,48	5,06	1,28	686,5	9,04	23,71	AHAM LBP
[°F]	-10	105	90	90										
[°C]	-35	45	32	45	436,6	1491	375,8	0,85	2,89	0,73	515,4	7,99	11,67	opt
[°F]	-31	113	89,6	113										

Performance tables

115V/60Hz, CSIR, fan 3m/s, UL

	pe		Cooling capacity			COP		EER		P1	I	m
	[°C]	[°F]	[W]	[Btu/h]	[kcal/h]	[W/W]	[Btu/Wh]	[kcal/Wh]	[W]	[A]	[kg/h]	
[°C / °F]	-45	-49	193,6	661	166,6	0,54	1,85	0,47	358,1	7,09	5,14	
cond. pressure	-34,4	-30	452,7	1546	389,6	0,86	2,95	0,74	524,0	8,04	12,11	
pc= 45/113	-28,9	-20	631,1	2155	543,1	1,03	3,53	0,89	610,6	8,57	16,96	
return gas temp.	-23,3	-10	844,2	2883	726,5	1,21	4,12	1,04	699,2	9,12	22,81	
RGT= 32/90	-20,6	-5	965,3	3297	830,7	1,30	4,43	1,12	744,9	9,40	26,17	
liquid temp	-15	5	1239,2	4232	1066,5	1,47	5,04	1,27	840,4	9,98	33,85	
Tliq= 45/113	-5	23	1851,8	6324	1593,7	1,80	6,13	1,55	1031,5	11,07	51,48	
[°C / °F]	-45	-49	92,8	317	79,8	0,28	0,97	0,25	325,6	6,90	2,85	
cond. pressure	-34,4	-30	317,1	1083	272,9	0,60	2,06	0,52	526,2	8,00	9,81	
pc= 55/131	-28,9	-20	469,0	1602	403,6	0,75	2,55	0,64	628,3	8,61	14,59	
return gas temp	-23,3	-10	650,0	2220	559,4	0,89	3,04	0,77	730,8	9,24	20,36	
RGT= 32/90	-20,6	-5	752,9	2571	648,0	0,96	3,29	0,83	782,8	9,56	23,67	
liquid temp	-15	5	986,3	3369	848,9	1,11	3,79	0,95	889,4	10,22	31,28	
Tliq= 55/131	-5	23	1511,8	5163	1301,1	1,38	4,71	1,19	1096,2	11,46	48,93	

Model

Designation **SC15CLX.2 115V/60Hz** Conf. 2 Sales code: **104L1853**

Configuration

Motorconfiguration **CSCR**
 Power supply (nominal) **115V/60Hz 1~**
 Refrigerant **R404A**
 Application **LBP**
 Voltage range **103-127V**
 Starting torque **HST**
 Approvals **UL**

Electrical accessories / wiring diagram

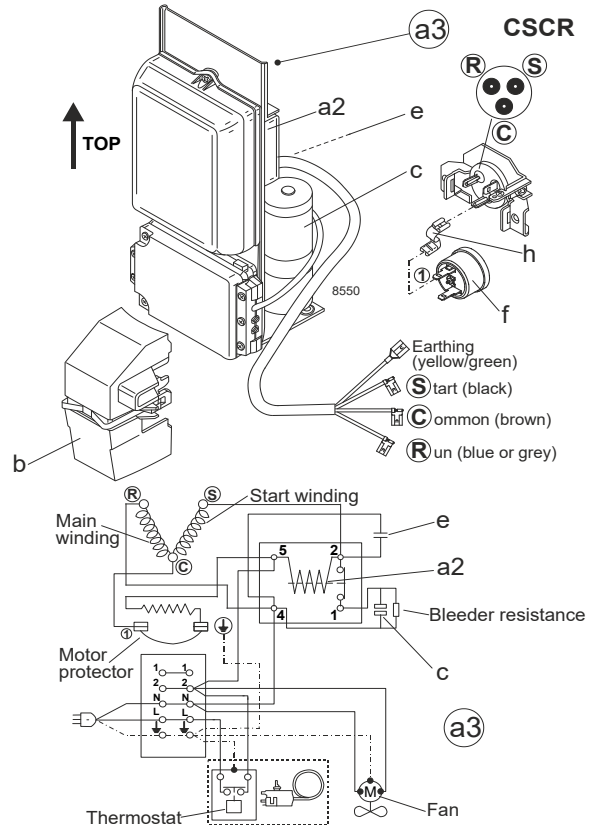

Ambient temperatures / system cooling

Ambient temperature min.: **10°C / 50°F**
 Ambient temperature max.: **43°C / 110°F**

System cooling (n/a: outside limits)			
T ambient	LBP	MBP	HBP
32°C / 90°F	fan 3m/s	n/a	n/a
38°C / 100°F	fan 3m/s	n/a	n/a
43°C / 110°F	fan 3m/s	n/a	n/a

Operation pressure range

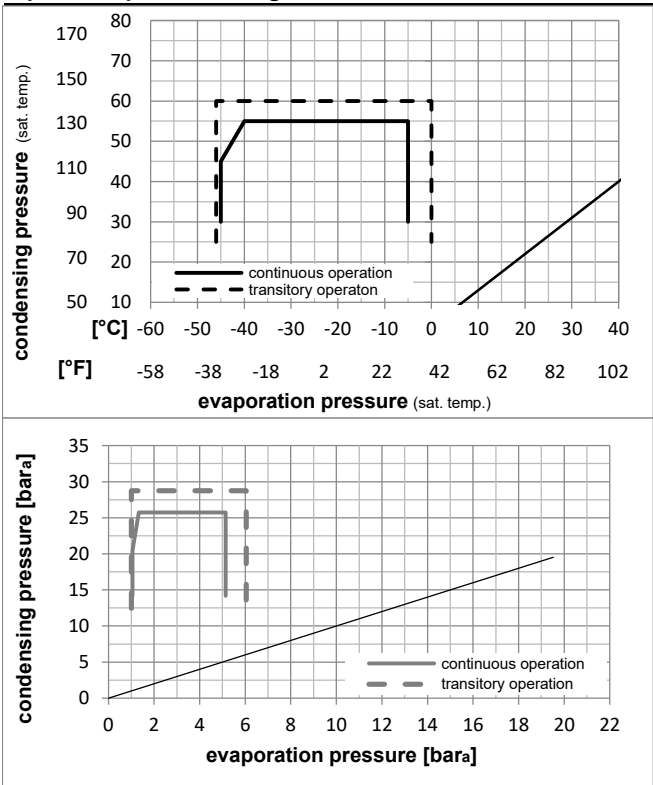

Components (protector + ~holder + cover: pre assembled)

- a3 SC starter kit 117-7045
- f ext. protector (T0761/46) 117U3212
- b plastic cover 117U1021

Alternative comp. (protector + ~holder + cover: pre assemb.)

- a2 potential relay (RVA 7AA3R) 117-7441
- e run capacitor (23,5µF, 6.3mm) 117-7114
- c start capacitor (410µF, 6.3mm) 117U5043
- f ext. protector (T0761/46) 117U3212
- b plastic cover 117U1021

Model

Designation **SC15CLX.2 115V/60Hz** Conf. **2** Sales code: **104L1853**

Optimization + standard conditions

115V/60Hz, CSCR, fan 3m/s, UL

Evaporating pressure (saturation temperature)														
Condensing pressure (saturation temperature)														
Return gas temp.														
Liquid temp.														
Cooling capacity														
COP														
EER														
Power consumption														
Current consumption														
Ref. mass flow														
	pe	pc	RGT	Tliq	[W]	[Btu/h]	[kcal/h]	[W/W]	[Btu/Wh]	[kcal/Wh]	P1	I	m	
[°C]	[°C]	[°C]	[°C]	[°C]							[W]	[A]	[kg/h]	
[°F]	-23,3	54,4	32,2	32,2	873,9	2984	752,1	1,27	4,32	1,09	690,2	7,23	20,36	ASHRAE LBP
[°F]	-10	130	90	90										
[°C]	-25	55	32	55	588,2	2009	506,2	0,89	3,03	0,76	662,5	7,02	18,38	cecomaf LBP
[°F]	-13	131	89,6	131										
[°C]	-35	40	20	40	475,2	1623	409,0	0,98	3,36	0,85	482,6	5,65	12,91	EN12900 LBP
[°F]	-31	104	68	104										
[°C]	-23,3	48,9	4,44	48,9	660,1	2254	568,1	0,98	3,34	0,84	675,8	7,09	23,37	ARI540 LBP
[°F]	-10	120	40	120										
[°C]	-23,3	40,6	32,2	32,2	1010,2	3450	869,4	1,55	5,28	1,33	653,7	6,83	23,54	AHAM LBP
[°F]	-10	105	90	90										
[°C]	-35	45	32	45	433,9	1482	373,4	0,89	3,04	0,77	487,3	5,73	11,60	opt
[°F]	-31	113	89,6	113										

Performance tables

115V/60Hz, CSCR, fan 3m/s, UL

	pe	Cooling capacity			COP	EER	P1	I	m			
		[°C]	[°F]	[W]						[Btu/h]	[kcal/h]	[W/W]
[°C / °F]	-45	-49		191,5	654	164,8	0,60	2,03	0,51	321,3	4,88	5,09
cond. pressure	-34,4	-30		449,9	1536	387,2	0,91	3,10	0,78	496,0	5,78	12,03
pc= 45/113	-28,9	-20		626,7	2140	539,4	1,08	3,68	0,93	581,4	6,34	16,84
return gas temp.	-23,3	-10		838,1	2862	721,3	1,26	4,30	1,08	665,7	6,96	22,65
RGT= 32/90	-20,6	-5		958,3	3273	824,8	1,35	4,62	1,16	708,3	7,30	25,98
liquid temp	-15	5		1230,8	4203	1059,2	1,55	5,28	1,33	795,9	8,03	33,62
Tliq= 45/113	-5	23		1842,5	6293	1585,7	1,90	6,49	1,64	969,1	9,54	51,22
[°C / °F]	-45	-49		91,2	312	78,5	0,32	1,08	0,27	287,7	4,88	2,80
cond. pressure	-34,4	-30		315,2	1076	271,2	0,64	2,18	0,55	494,0	5,92	9,75
pc= 55/131	-28,9	-20		465,8	1591	400,9	0,78	2,68	0,67	594,1	6,55	14,49
return gas temp	-23,3	-10		645,5	2204	555,5	0,93	3,19	0,80	691,6	7,24	20,22
RGT= 32/90	-20,6	-5		747,7	2554	643,5	1,01	3,45	0,87	740,3	7,60	23,51
liquid temp	-15	5		980,1	3347	843,4	1,17	3,99	1,01	839,1	8,38	31,08
Tliq= 55/131	-5	23		1505,6	5142	1295,7	1,46	5,00	1,26	1028,8	9,97	48,73

Model

Designation **SC15CLX.2 115V/60Hz** Conf. 3 Sales code: **104L1853**

Configuration

Motorconfiguration CSIR
 Power supply (nominal) 115V/60Hz 1~
 Refrigerant R452A
 Application LBP
 Voltage range 103-127V
 Starting torque HST
 Approvals UL

Electrical accessories / wiring diagram

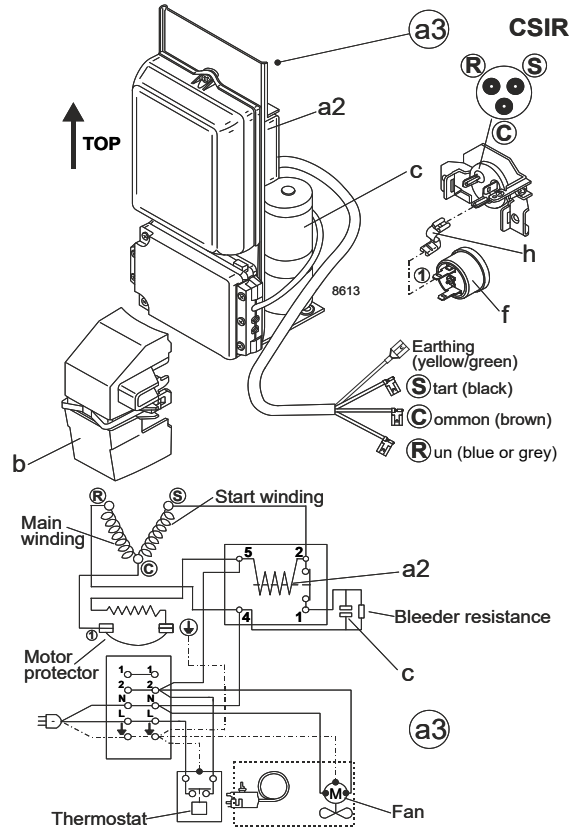

Ambient temperatures / system cooling

Ambient temperature min.: 10°C / 50°F
 Ambient temperature max.: 43°C / 110°F

System cooling (n/a: outside limits)			
T ambient	LBP	MBP	HBP
32°C / 90°F	fan 3m/s	n/a	n/a
38°C / 100°F	fan 3m/s	n/a	n/a
43°C / 110°F	fan 3m/s	n/a	n/a

Operation pressure range

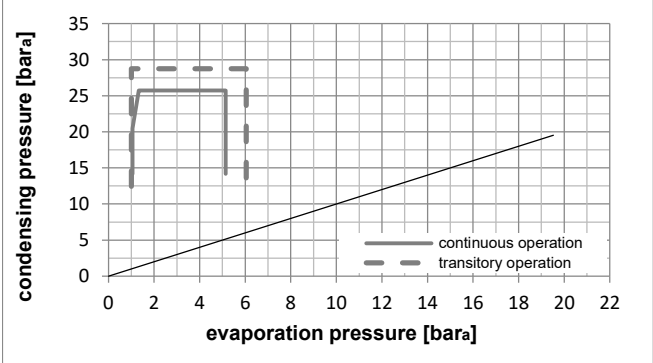
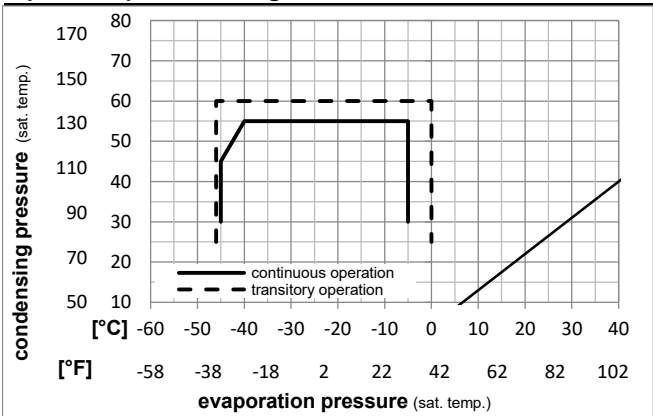

Components (protector + ~holder + cover: pre assembled)

- a3 SC starter kit 117-7053
- f ext. protector (T0761/46) 117U3212
- h protector holder 117U0439
- b plastic cover 117U1021

Alternative comp. (protector + ~holder + cover: pre assemb.)

- a2 potential relay (RVA 7AA3R) 117-7441
- c start capacitor 117U5042
- f ext. protector (T0761/46) 117U3212
- h protector holder 117U0439
- b plastic cover 117U1021

Model

Designation **SC15CLX.2 115V/60Hz** Conf. **3** Sales code: **104L1853**

Optimization + standard conditions

115V/60Hz, CSIR, fan 3m/s, UL

Evaporating pressure (saturation temperature)				Condensing pressure (saturation temperature)				Power consumption				ASHRAE LBP		
Return gas temp.				Liquid temp.				Current consumption					Ref. mass flow ṁ	
Cooling capacity				COP		EER		P1		I				
pe	pc	RGT	Tliq	[W]	[Btu/h]	[kcal/h]	[W/W]	[Btu/Wh]	[kcal/Wh]	[W]	[A]		[kg/h]	
[°C]	-23,3	54,4	32,2	32,2	803,7	2745	691,6	1,18	4,05	1,02	678,4	8,93	19,32	ASHRAE LBP
[°F]	-10	130	90	90										
[°C]	-25	55	32	55	545,4	1863	469,3	0,84	2,87	0,72	649,8	8,77	17,35	cecomaf LBP
[°F]	-13	131	89,6	131										
[°C]	-35	40	20	40	430,7	1471	370,7	0,90	3,07	0,77	478,9	7,80	12,03	EN12900 LBP
[°F]	-31	104	68	104										
[°C]	-23,3	48,9	4,44	48,9	617,0	2107	531,0	0,93	3,17	0,80	663,6	8,85	22,18	ARI540 LBP
[°F]	-10	120	40	120										
[°C]	-23,3	40,6	32,2	32,2	935,4	3194	805,0	1,46	4,98	1,25	641,8	8,73	22,48	AHAM LBP
[°F]	-10	105	90	90										
[°C]	-35	45	32	45	392,1	1339	337,4	0,81	2,78	0,70	481,2	7,81	10,76	opt
[°F]	-31	113	89,6	113										

Performance tables

115V/60Hz, CSIR, fan 3m/s, UL

	pe		Cooling capacity			COP		EER		P1	I	m
	[°C]	[°F]	[W]	[Btu/h]	[kcal/h]	[W/W]	[Btu/Wh]	[kcal/Wh]	[W]	[A]	[kg/h]	
[°C / °F]	-45	-49	164,3	561	141,4	0,47	1,61	0,41	348,3	7,05	4,48	
cond. pressure	-34,4	-30	407,2	1391	350,5	0,83	2,84	0,72	488,9	7,85	11,18	
pc= 45/113	-28,9	-20	575,9	1967	495,6	1,01	3,46	0,87	568,4	8,31	15,88	
return gas temp.	-23,3	-10	779,1	2661	670,5	1,19	4,07	1,03	653,2	8,79	21,59	
RGT= 32/90	-20,6	-5	895,1	3057	770,4	1,28	4,38	1,10	698,0	9,05	24,87	
liquid temp	-15	5	1159,1	3958	997,5	1,46	4,99	1,26	793,0	9,59	32,42	
Tliq= 45/113	-5	23	1754,8	5993	1510,2	1,78	6,08	1,53	985,8	10,69	49,86	
[°C / °F]	-45	-49	73,2	250	63,0	0,23	0,79	0,20	315,1	6,86	2,29	
cond. pressure	-34,4	-30	283,4	968	243,9	0,58	1,99	0,50	487,2	7,84	8,94	
pc= 55/131	-28,9	-20	427,4	1460	367,8	0,74	2,51	0,63	581,5	8,38	13,55	
return gas temp	-23,3	-10	600,7	2052	517,0	0,88	3,02	0,76	679,8	8,94	19,15	
RGT= 32/90	-20,6	-5	699,9	2390	602,3	0,96	3,27	0,82	730,8	9,23	22,39	
liquid temp	-15	5	926,2	3163	797,1	1,11	3,78	0,95	837,5	9,84	29,85	
Tliq= 55/131	-5	23	1441,1	4922	1240,2	1,38	4,70	1,18	1047,9	11,04	47,30	

Model

Designation **SC15CLX.2 115V/60Hz** Conf. 4 Sales code: **104L1853**

Configuration

Motorconfiguration **CSCR**
 Power supply (nominal) **115V/60Hz 1~**
 Refrigerant **R452A**
 Application **LBP**
 Voltage range **103-127V**
 Starting torque **HST**
 Approvals **UL**

Electrical accessories / wiring diagram

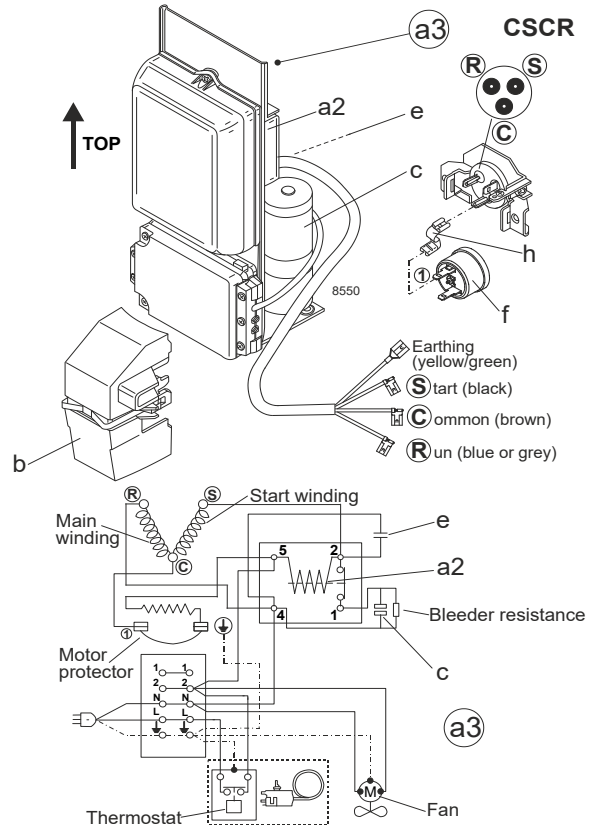

Ambient temperatures / system cooling

Ambient temperature min.: **10°C / 50°F**
 Ambient temperature max.: **43°C / 110°F**

System cooling (n/a: outside limits)			
T ambient	LBP	MBP	HBP
32°C / 90°F	fan 3m/s	n/a	n/a
38°C / 100°F	fan 3m/s	n/a	n/a
43°C / 110°F	fan 3m/s	n/a	n/a

Operation pressure range

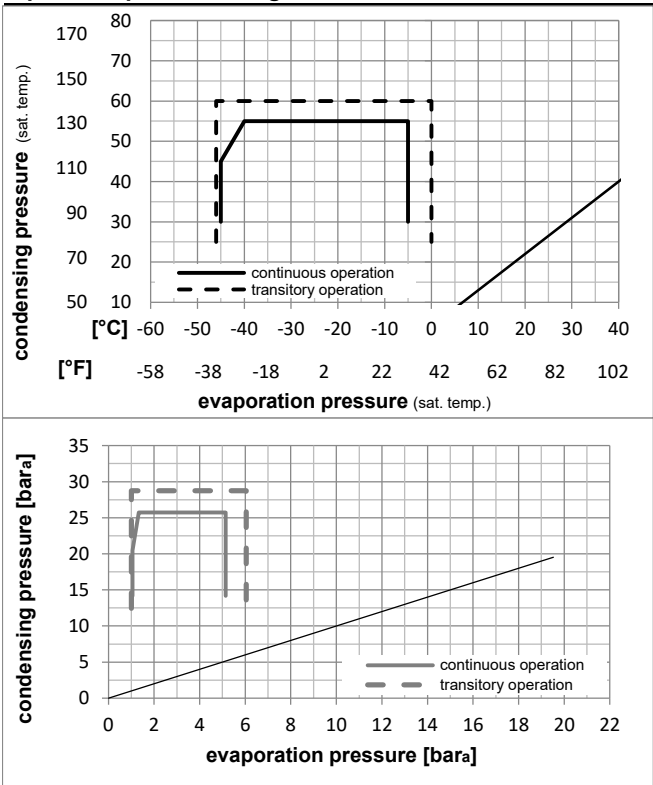

Components (protector + ~holder + cover: pre assembled)

- a3 SC starter kit 117-7045
- f ext. protector (T0761/46) 117U3212
- b plastic cover 117U1021

Alternative comp. (protector + ~holder + cover: pre assemb.)

- a2 potential relay (RVA 7AA3R) 117-7441
- e run capacitor (23,5µF, 6.3mm) 117-7114
- c start capacitor (410µF, 6.3mm) 117U5043
- f ext. protector (T0761/46) 117U3212
- b plastic cover 117U1021

Model

Designation **SC15CLX.2 115V/60Hz** Conf. 4 Sales code: **104L1853**

Optimization + standard conditions

115V/60Hz, CSCR, fan 3m/s, UL

Evaporating pressure (saturation temperature)				Condensing pressure (saturation temperature)				Power consumption				ASHRAE LBP		
Return gas temp.				Liquid temp.				Current consumption					Ref. mass flow m	
Cooling capacity				COP		EER		P1		I				
pe	pc	RGT	Tliq	[W]	[Btu/h]	[kcal/h]	[W/W]	[Btu/Wh]	[kcal/Wh]	[W]	[A]		[kg/h]	
[°C]	-23,3	54,4	32,2	32,2	797,9	2725	686,7	1,24	4,24	1,07	643,1	6,90	19,18	ASHRAE LBP
[°F]	-10	130	90	90										
[°C]	-25	55	32	55	541,5	1849	466,0	0,88	3,01	0,76	615,3	6,70	17,23	cecomaf LBP
[°F]	-13	131	89,6	131										
[°C]	-35	40	20	40	428,2	1462	368,5	0,96	3,29	0,83	444,5	5,42	11,96	EN12900 LBP
[°F]	-31	104	68	104										
[°C]	-23,3	48,9	4,44	48,9	612,5	2092	527,1	0,97	3,31	0,84	631,1	6,77	22,02	ARI540 LBP
[°F]	-10	120	40	120										
[°C]	-23,3	40,6	32,2	32,2	928,6	3171	799,2	1,52	5,18	1,31	611,7	6,52	22,32	AHAM LBP
[°F]	-10	105	90	90										
[°C]	-35	45	32	45	389,6	1331	335,3	0,87	2,98	0,75	447,1	5,48	10,69	opt
[°F]	-31	113	89,6	113										

Performance tables

115V/60Hz, CSCR, fan 3m/s, UL

	pe	Cooling capacity			COP		EER		P1	I	m
	[°C]	[°F]	[W]	[Btu/h]	[kcal/h]	[W/W]	[Btu/Wh]	[kcal/Wh]	[W]	[A]	[kg/h]
[°C / °F]	-45	-49	162,9	556	140,2	0,57	1,93	0,49	287,5	4,73	4,45
cond. pressure	-34,4	-30	404,7	1382	348,3	0,89	3,03	0,76	455,6	5,53	11,11
pc= 45/113	-28,9	-20	571,9	1953	492,2	1,06	3,62	0,91	539,1	6,05	15,77
return gas temp.	-23,3	-10	773,4	2641	665,6	1,24	4,24	1,07	622,3	6,65	21,43
RGT= 32/90	-20,6	-5	888,6	3035	764,7	1,34	4,57	1,15	664,6	6,97	24,69
liquid temp	-15	5	1151,0	3931	990,6	1,53	5,23	1,32	752,2	7,68	32,20
Tliq= 45/113	-5	23	1745,3	5961	1502,0	1,88	6,43	1,62	926,5	9,14	49,59
[°C / °F]	-45	-49	72,3	247	62,2	0,29	0,99	0,25	249,9	4,73	2,27
cond. pressure	-34,4	-30	281,7	962	242,4	0,63	2,14	0,54	449,5	5,67	8,89
pc= 55/131	-28,9	-20	424,5	1450	365,3	0,78	2,65	0,67	547,6	6,25	13,46
return gas temp	-23,3	-10	596,4	2037	513,3	0,93	3,16	0,80	644,3	6,90	19,01
RGT= 32/90	-20,6	-5	694,9	2373	598,0	1,00	3,43	0,86	692,8	7,26	22,23
liquid temp	-15	5	920,0	3142	791,8	1,16	3,97	1,00	791,9	8,01	29,66
Tliq= 55/131	-5	23	1434,4	4899	1234,4	1,46	4,98	1,25	983,8	9,55	47,08