

Model

Designation	SC15CLX.2	220-240V/50Hz 1~	Sales code:	104L2890
-------------	------------------	------------------	-------------	-----------------

Compressor design

Oil type	Polyolester	Refrigerant(s)	R404A, R507, R452A
Oil viscosity	32cST	Displacement	15,28cm ³ / 0,93cu.in
Oil quantity	494cm ³ / 16,7fl.oz	Compressors on pallet	80
Refr. charge - tech. limit	1300g / 45,9oz		
Free gas volume comp.	1510cm ³ / 51,1fl.oz		
Weight	13,8kg / 30,4lbs		
Motor protection	1# internal		
Winding resistance main	3,7Ω (at 25°C)		
Winding resistance aux	14Ω (at 25°C)		
Max. winding temp.	125°C / 257°F		
Max. discharge temp.	130°C / 266°F		



General - Configurations with SC15CLX.2

	Conf. 1	Conf. 2
Motorconfiguration	CSIR	CSIR
Power supply (nominal)	220-240V/50Hz	220-240V/50Hz
Number of phases	1	1
Voltage range	198-254V	198-254V
Approvals	VDE, EAC	VDE, EAC
Starting torque	HST	HST
Note	- / -	

Applications with SC15CLX.2

	Conf. 1	Conf. 2
Refrigerant	R404A	R452A
Application	LBP	LBP
System cooling	fan 3m/s	fan 3m/s
Hot gas defrost	OK	OK
Long interval pull down	OK	OK

Electrical data - Configurations with SC15CLX.2

	Conf. 1	Conf. 2
Starting device type	relay	relay
Run capacitor	-/-	-/-
Start capacitor	80μF	80μF
LRA (locked rotor amps / 4s)	20,43A	20,43A
RLA (rated load amps / 1s)	3,9A	3,9A
Cut in current	20,43A	20,43A
IP class	21	21

Model

Designation	SC15CLX.2	220-240V/50Hz 1~	Sales code:	104L2890
-------------	------------------	------------------	-------------	-----------------

Compressor dimensions

Housing	A Height	219mm / 8,62in
	B Height	213mm / 8,39in
	C Length shell	218mm / 8,58in
	D Length w. cover	255mm / 10,04in
	E Width	151mm / 5,94in

Connectors		Suction	Discharge	Process
		X	Y	Z
Diameter	[mm]	øi 10,11-10,29	øi 6,11-6,29	øi 6,11-6,29
(i:inside, o:outside)	[in]	øi 0,4-0,41	øi 0,24-0,25	øi 0,24-0,25
Material		copper	copper	copper
Horizontal angle	±2°	37°	37°	143°
Vertical angle	±2°	30°	0°	150°
Position l/h/w	[mm]	107/193/55	115/110/63	-107/193/55
	[in]	4,2/7,6/2,2	4,5/4,3/2,5	-4,2/7,6/2,2
Straight tube l.	[mm]	12	12	12
	[in]	0,5	0,5	0,5

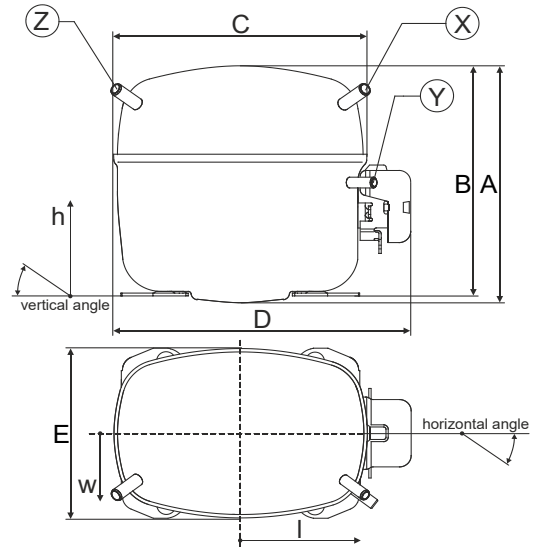

Compressor fixation

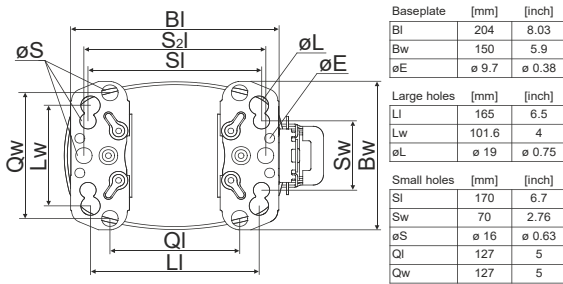

Bolt joint

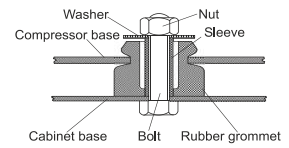

Snap-on

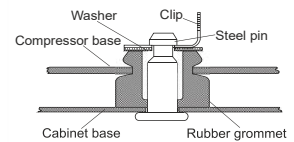

Mounting accessories

	one comp.	multi pack
Bolt joint M6 ø16mm	118-1917	118-1918
Bolt joint ø1/4" ø16mm	118-1946	
Bolt joint ø1/4" ø19mm	118-1949	
Snap-on ø7,3 ø16mm	118-1947	118-1919

Model

Designation	SC15CLX.2	220-240V/50Hz	Conf. 1	Sales code:	104L2890
-------------	------------------	----------------------	----------------	-------------	-----------------

Configuration

Motorconfiguration	CSIR
Power supply (nominal)	220-240V/50Hz 1~
Refrigerant	R404A
Application	LBP
Voltage range	198-254V
Starting torque	HST
Approvals	VDE EAC

Electrical accessories / wiring diagram

CSIR

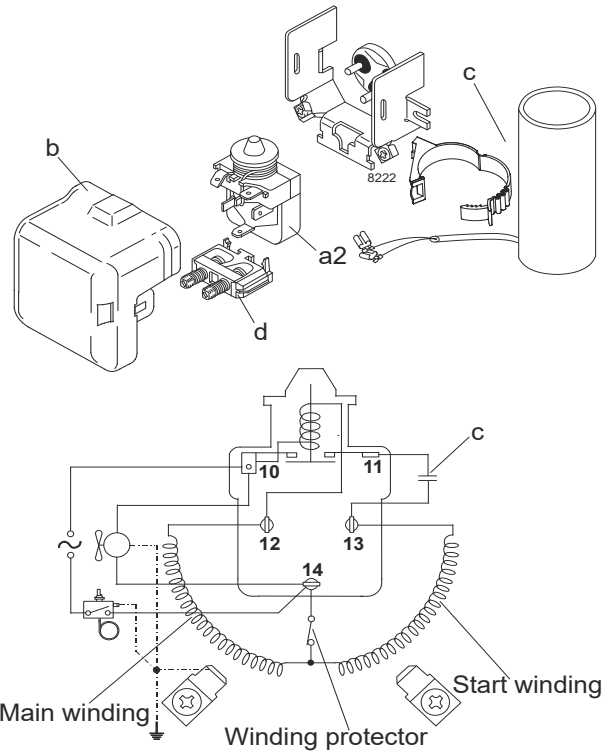

Ambient temperatures / system cooling

Ambient temperature min.:	10°C / 50°F
Ambient temperature max.:	38°C / 101°F

System cooling (n/a: outside limits)			
T ambient	LBP	MBP	HBP
32°C / 90°F	fan 3m/s	n/a	n/a
38°C / 100°F	fan 3m/s	n/a	n/a
43°C / 110°F	n/a	n/a	n/a

Operation pressure range

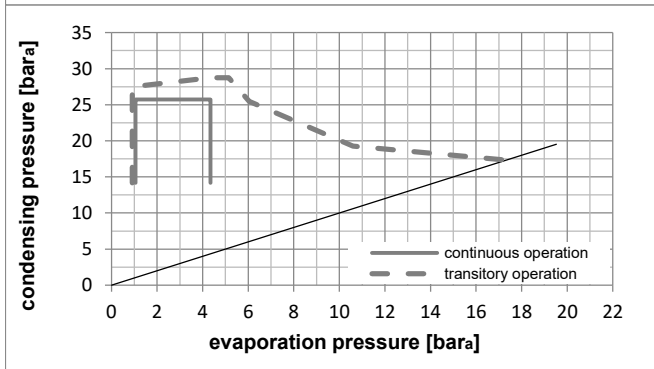
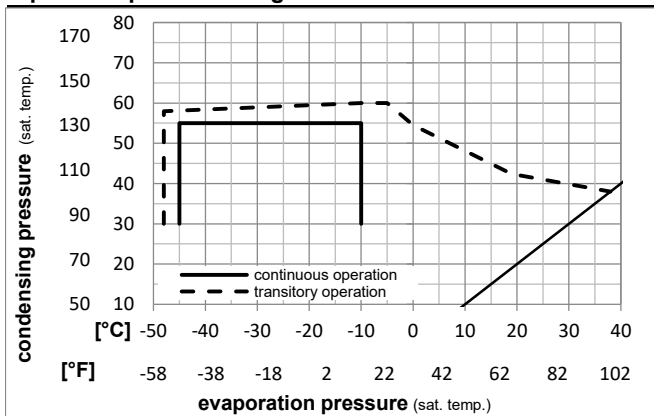

Components

a2	relay	117U6019
c	start capacitor (80µF)	117U5017
d	cord relief	103N1004
b	plastic cover	103N2009

Model

Designation **SC15CLX.2 220-240V/50Hz** Conf. 1 Sales code: **104L2890**

Optimization + standard conditions

R404A, 220V/50Hz, CSIR, fan 3m/s, VDE, EAC

Evaporating pressure (saturation temperature)														
Condensing pressure (saturation temperature)														
Return gas temp.														
Liquid temp.														
Cooling capacity														
COP														
EER														
Power consumption														
Current consumption														
Ref. mass flow														
	pe	pc	RGT	Tliq	[W]	[Btu/h]	[kcal/h]	[W/W]	[Btu/Wh]	[kcal/Wh]	P1	I	m	
[°C]	[°C]	[°C]	[°C]	[°C]							[W]	[A]	[kg/h]	
[°F]	-23,3	54,4	32,2	32,2	722,1	2466	621,4	1,18	4,03	1,01	612,4	3,85	16,82	ASHRAE LBP
[°F]	-10	130	90	90										
[°C]	-25	55	32	55	486,1	1660	418,3	0,83	2,82	0,71	588,0	3,77	15,19	cecomaf LBP
[°F]	-13	131	89,6	131										
[°C]	-35	40	20	40	392,3	1340	337,6	0,91	3,11	0,78	430,8	3,30	10,66	EN12900 LBP
[°F]	-31	104	68	104										
[°C]	-23,3	48,9	4,44	48,9	545,6	1863	469,5	0,91	3,12	0,79	597,4	3,83	19,32	ARI540 LBP
[°F]	-10	120	40	120										
[°C]	-23,3	40,6	32,2	32,2	834,8	2851	718,4	1,45	4,94	1,25	576,8	3,77	19,45	AHAM LBP
[°F]	-10	105	90	90										
[°C]	-35	45	32	45	358,3	1224	308,3	0,83	2,83	0,71	433,0	3,31	9,58	opt
[°F]	-31	113	89,6	113										

Performance tables

R404A, 220V/50Hz, CSIR, fan 3m/s, VDE, EAC

	pe	Cooling capacity			COP	EER	P1	I	m			
		[°C]	[°F]	[W]						[Btu/h]	[kcal/h]	[W/W]
[°C / °F]	-45	-49		158,9	543	136,7	0,53	1,80	0,45	300,8	2,91	4,22
cond. pressure	-35	-31		358,3	1224	308,3	0,83	2,83	0,71	433,0	3,31	9,58
pc= 45/113	-30	-22		486,4	1661	418,6	0,98	3,33	0,84	498,3	3,51	13,06
return gas temp.	-25	-13		637,0	2175	548,2	1,13	3,85	0,97	564,8	3,73	17,18
RGT= 32/90	-20	-4		812,9	2776	699,6	1,28	4,38	1,10	633,6	3,95	22,05
liquid temp	-15	5		1016,8	3473	875,1	1,44	4,92	1,24	706,0	4,18	27,78
Tliq= 45/113	-10	14		1251,4	4274	1077,0	1,60	5,46	1,37	783,3	4,42	34,46
[°C / °F]	-45	-49		76,1	260	65,5	0,28	0,95	0,24	273,6	2,82	2,34
cond. pressure	-35	-31		248,9	850	214,2	0,57	1,96	0,49	433,4	3,28	7,70
pc= 55/131	-30	-22		358,1	1223	308,2	0,70	2,39	0,60	510,7	3,52	11,13
return gas temp	-25	-13		486,1	1660	418,3	0,83	2,82	0,71	588,0	3,77	15,19
RGT= 32/90	-20	-4		635,6	2171	547,0	0,95	3,26	0,82	666,4	4,03	20,00
liquid temp	-15	5		809,3	2764	696,5	1,08	3,70	0,93	747,2	4,29	25,67
Tliq= 55/131	-10	14		1010,0	3449	869,3	1,21	4,15	1,05	831,7	4,56	32,33

Model

Designation **SC15CLX.2 220-240V/50Hz** Conf. 2 Sales code: **104L2890**

Configuration

Motorconfiguration CSIR
 Power supply (nominal) 220-240V/50Hz 1~
 Refrigerant R452A
 Application LBP
 Voltage range 198-254V
 Starting torque HST
 Approvals VDE
 EAC

Electrical accessories / wiring diagram

CSIR

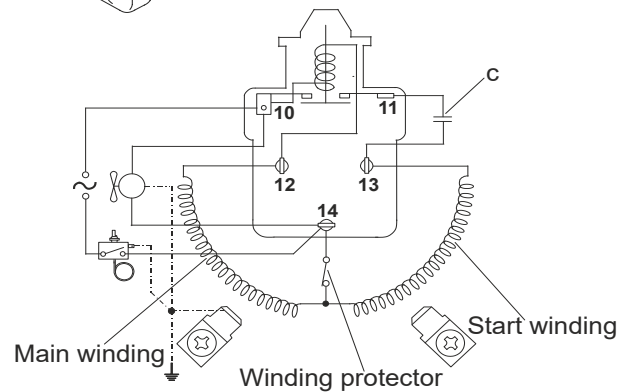
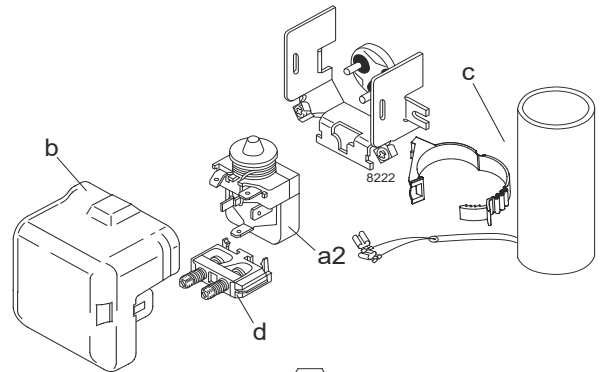

Ambient temperatures / system cooling

Ambient temperature min.: 10°C / 50°F
 Ambient temperature max.: 38°C / 101°F

System cooling (n/a: outside limits)			
T ambient	LBP	MBP	HBP
32°C / 90°F	fan 3m/s	n/a	n/a
38°C / 100°F	fan 3m/s	n/a	n/a
43°C / 110°F	n/a	n/a	n/a

Operation pressure range

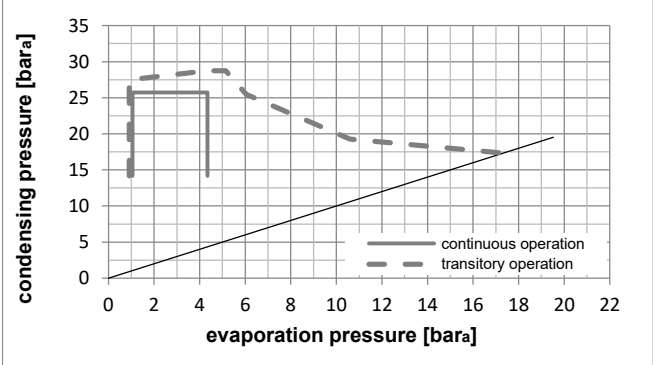
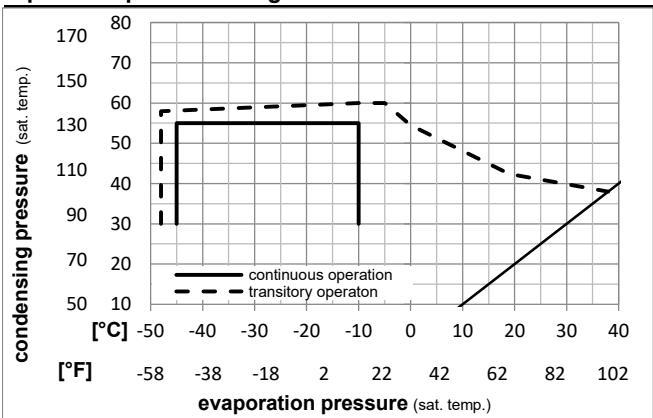

Components

- a2 relay 117U6019
- c start capacitor (80µF) 117U5017
- d cord relief 103N1004
- b plastic cover 103N2009

Model

Designation **SC15CLX.2 220-240V/50Hz** Conf. **2** Sales code: **104L2890**

Optimization + standard conditions

R452A, 220V/50Hz, CSIR, fan 3m/s, VDE, EAC

Evaporating pressure (saturation temperature)					Condensing pressure (saturation temperature)						Power consumption								
					Return gas temp.			Liquid temp.			Cooling capacity			COP	EER	P1	I	Ref. mass flow	
pe	pc	RGT	Tliq		[W]	[Btu/h]	[kcal/h]	[W/W]	[Btu/Wh]	[kcal/Wh]	[W]	[A]	[kg/h]						
[°C]	-23	54,4	32,2	32,2	666,6	2277	573,7	1,16	3,96	1,00	574,8	3,52	16,02	ASHRAE LBP					
[°F]	-10	130	90	90															
[°C]	-25	55	32	55	453,1	1547	389,9	0,82	2,81	0,71	550,9	3,44	14,42	cecomaf LBP					
[°F]	-13	131	89,6	131															
[°C]	-35	40	20	40	358,0	1223	308,1	0,89	3,06	0,77	400,1	2,95	10,00	EN12900 LBP					
[°F]	-31	104	68	104															
[°C]	-23	48,9	4,44	48,9	510,6	1744	439,5	0,91	3,11	0,78	561,0	3,47	18,35	ARI540 LBP					
[°F]	-10	120	40	120															
[°C]	-23	40,6	32,2	32,2	772,1	2637	664,5	1,43	4,87	1,23	541,7	3,39	18,56	AHAM LBP					
[°F]	-10	105	90	90															
[°C]	-35	45	32	45	327,0	1117	281,4	0,81	2,78	0,70	401,9	2,96	8,97	opt					
[°F]	-31	113	89,6	113															

Performance tables

R452A, 220V/50Hz, CSIR, fan 3m/s, VDE, EAC

	pe	Cooling capacity			COP	EER	P1	I	m		
	[°C]	[°F]	[W]	[Btu/h]	[kcal/h]	[W/W]	[Btu/Wh]	[kcal/Wh]	[W]	[A]	[kg/h]
[°C / °F]	-45	-49	140,0	478	120,5	0,51	1,73	0,44	276,0	2,65	3,82
cond. pressure	-35	-31	327,0	1117	281,4	0,81	2,78	0,70	401,9	2,96	8,97
pc= 45/113	-30	-22	447,9	1529	385,4	0,96	3,29	0,83	464,9	3,14	12,34
return gas temp.	-25	-13	590,9	2018	508,5	1,12	3,81	0,96	529,5	3,35	16,35
RGT= 32/90	-20	-4	759,0	2592	653,2	1,27	4,34	1,09	597,0	3,59	21,10
liquid temp	-15	5	955,2	3262	822,1	1,43	4,88	1,23	668,4	3,86	26,72
Tliq= 45/113	-10	14	1182,5	4038	1017,7	1,59	5,42	1,37	745,0	4,17	33,32
[°C / °F]	-45	-49	65,5	224	56,3	0,26	0,90	0,23	249,3	2,57	2,05
cond. pressure	-35	-31	227,8	778	196,0	0,57	1,94	0,49	401,2	2,96	7,18
pc= 55/131	-30	-22	331,1	1131	284,9	0,70	2,38	0,60	475,7	3,19	10,48
return gas temp	-25	-13	453,1	1547	389,9	0,82	2,81	0,71	550,9	3,44	14,42
RGT= 32/90	-20	-4	596,7	2038	513,5	0,95	3,25	0,82	627,7	3,71	19,10
liquid temp	-15	5	765,0	2613	658,3	1,08	3,69	0,93	707,6	4,02	24,66
Tliq= 55/131	-10	14	960,8	3281	826,9	1,21	4,15	1,04	791,5	4,36	31,23