

Model

Designation	SC15MFX	220-240V/50Hz 1~	Sales code:	104G8501
-------------	----------------	------------------	-------------	-----------------

Compressor design

Oil type	Polyolester	Refrigerant(s)	R134a, R513A
Oil viscosity	22cST	Displacement	15,28cm ³ / 0,93cu.in
Oil quantity	446cm ³ / 15,1fl.oz	Compressors on pallet	80
Refr. charge - tech. limit	1300g / 45,9oz		
Free gas volume comp.	1410cm ³ / 47,7fl.oz		
Weight	13,2kg / 29,1lbs		
Motor protection	1# internal		
Winding resistance main	5,13Ω (at 25°C)		
Winding resistance aux	13,51Ω (at 25°C)		
Max. winding temp.	125°C / 257°F		
Max. discharge temp.	130°C / 266°F		



General - Configurations with SC15MFX

	Conf. 1	Conf. 2
Motorconfiguration	CSIR	CSIR
Power supply (nominal)	220-240V/50Hz	220-240V/50Hz
Number of phases	1	1
Voltage range	198-254V	198-254V
Approvals	VDE, CCC, EAC	VDE, CCC, EAC
Starting torque	HST	HST
Note	- / -	

Applications with SC15MFX

	Conf. 1	Conf. 2
Refrigerant	R134a	R513A
Application	MBP	MBP
System cooling	fan 3m/s	fan 3m/s
Hot gas defrost	OK	OK
Long interval pull down	OK	OK

Electrical data - Configurations with SC15MFX

	Conf. 1	Conf. 2
Starting device type	relay	relay
Run capacitor	- / -	- / -
Start capacitor	80μF	80μF
LRA (locked rotor amps / 4s)	16,2A	16,2A
RLA (rated load amps / 1s)	3,1A	3,1A
Cut in current	16,2A	16,2A
IP class	21	21

Model

Designation	SC15MFX	220-240V/50Hz 1~	Sales code:	104G8501
-------------	----------------	------------------	-------------	-----------------

Compressor dimensions

Housing	A Height	209mm / 8,23in
	B Height	203mm / 7,99in
	C Length shell	218mm / 8,58in
	D Length w. cover	255mm / 10,04in
	E Width	151mm / 5,94in

Connectors		Suction	Discharge	Process
		X	Y	Z
Diameter	[mm]	øi 10,11-10,29	øi 6,11-6,29	øi 6,11-6,29
(i:inside, o:outside)	[in]	øi 0,4-0,41	øi 0,24-0,25	øi 0,24-0,25
Material		copper	copper	copper
Horizontal angle	±2°	37°	37°	143°
Vertical angle	±2°	30°	0°	150°
Position l/h/w	[mm]	107/183/55	115/100/63	-107/183/55
	[in]	4,2/7,2/2,2	4,5/3,9/2,5	-4,2/7,2/2,2
Straight tube l.	[mm]	12	12	12
	[in]	0,5	0,5	0,5

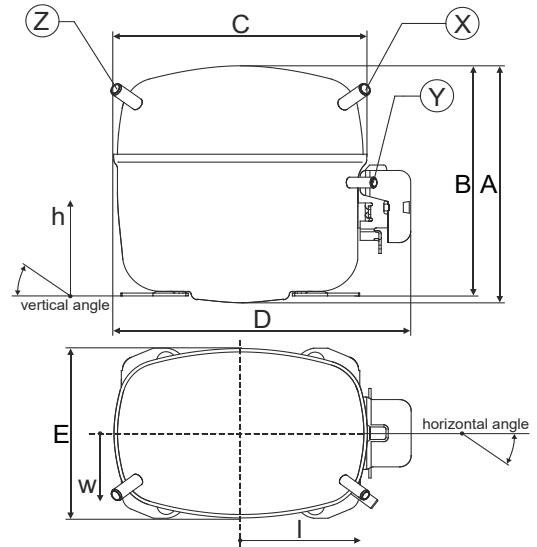

Compressor fixation

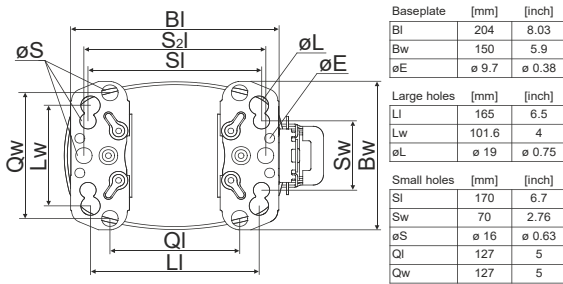

Baseplate	[mm]	[inch]
BI	204	8.03
Bw	150	5.9
øE	ø 9.7	ø 0.38
Large holes		
LI	165	6.5
Lw	101.6	4
øL	ø 19	ø 0.75
Small holes		
SI	170	6.7
Sw	70	2.76
øS	ø 16	ø 0.63
QI	127	5
Qw	127	5

Bolt joint

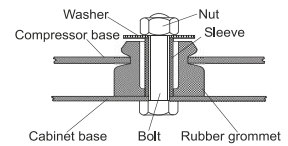

Snap-on

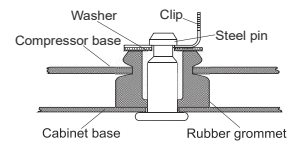

Mounting accessories

	one comp.	multi pack
Bolt joint M6 ø16mm	118-1917	118-1918
Bolt joint ø1/4" ø16mm	118-1946	
Bolt joint ø1/4" ø19mm	118-1949	
Snap-on ø7,3 ø16mm	118-1947	118-1919

Model

Designation	SC15MFX	220-240V/50Hz	Conf. 1	Sales code:	104G8501
-------------	----------------	----------------------	----------------	-------------	-----------------

Configuration

Motorconfiguration	CSIR
Power supply (nominal)	220-240V/50Hz 1~
Refrigerant	R134a
Application	MBP
Voltage range	198-254V
Starting torque	HST
Approvals	VDE CCC EAC

Electrical accessories / wiring diagram

CSIR

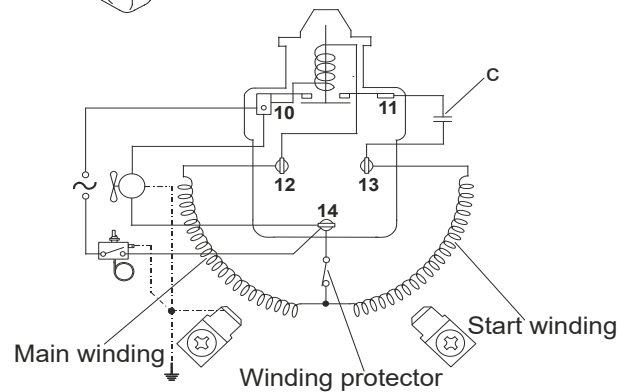
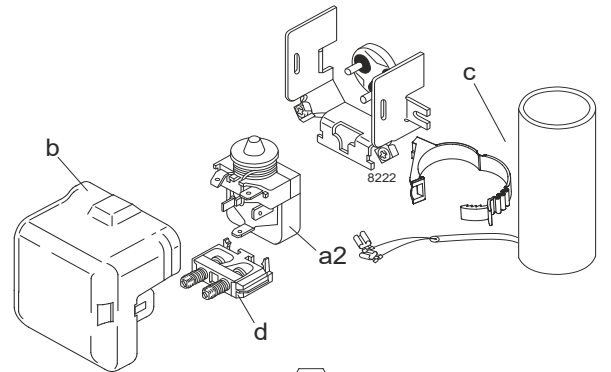

Ambient temperatures / system cooling

Ambient temperature min.:	10°C / 50°F
Ambient temperature max.:	43°C / 110°F

System cooling (n/a: outside limits)			
T ambient	LBP	MBP	HBP
32°C / 90°F	n/a	fan 3m/s	n/a
38°C / 100°F	n/a	fan 3m/s	n/a
43°C / 110°F	n/a	fan 3m/s	n/a

Operation pressure range

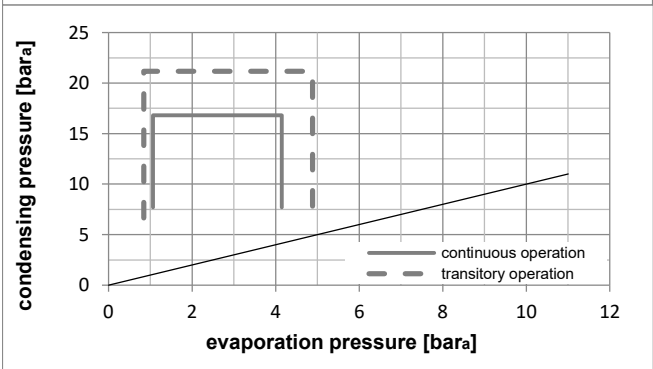
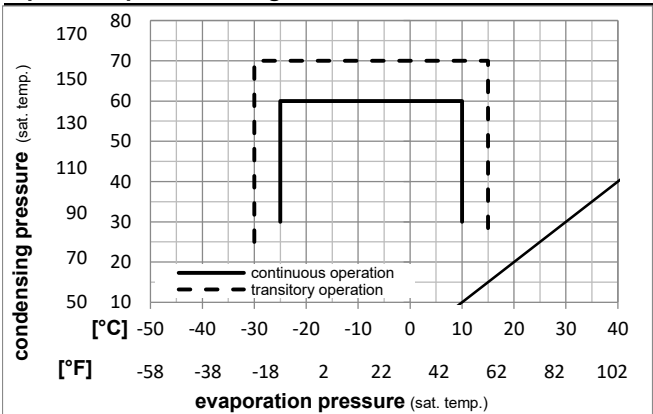

Components

a2	relay	117U6005
c	start capacitor (80µF)	117U5017
d	cord relief	103N1004
b	plastic cover	103N2008

Model

Designation **SC15MFX 220-240V/50Hz** Conf. 1 Sales code: **104G8501**

Optimization + standard conditions

R134a, 220V/50Hz, CSIR, fan 3m/s, VDE, CCC, EAC

Evaporating pressure (saturation temperature)														
Condensing pressure (saturation temperature)														
Return gas temp.														
Liquid temp.														
Cooling capacity														
COP														
EER														
Power consumption														
Current consumption														
Ref. mass flow														
	pe	pc	RGT	Tliq	[W]	[Btu/h]	[kcal/h]	[W/W]	[Btu/Wh]	[kcal/Wh]	P1	I	m	
[°C]	[°C]	[°C]	[°C]	[°C]	[W]	[Btu/h]	[kcal/h]	[W/W]	[Btu/Wh]	[kcal/Wh]	[W]	[A]	[kg/h]	
-6,66	54,4	35	46,1	786,3	2685	676,7	1,66	5,68	1,43	472,7	2,90	17,16	ASHRAE	
[°F]	20	130	95	115									MBP	
-10	55	32	55	601,6	2054	517,7	1,38	4,70	1,18	437,4	2,78	14,55	cecomaf	
[°F]	14	131	89,6	131									MBP	
-10	45	20	45	676,2	2309	582,0	1,63	5,57	1,40	414,4	2,70	15,83	EN12900	
[°F]	14	113	68	113									MBP	
-6,66	48,9	18,3	48,9	746,6	2550	642,6	1,63	5,57	1,40	458,1	2,85	18,44	ARI540	
[°F]	20	120	65	120									MBP	
-10	45	32	45	701,6	2396	603,8	1,69	5,78	1,46	414,4	2,70	15,35	opt	
[°F]	14	113	89,6	113										
-25	45	32	45	290,0	990	249,6	1,07	3,66	0,92	270,3	2,25	6,28	opt	
[°F]	-13	113	89,6	113										

Performance tables

R134a, 220V/50Hz, CSIR, fan 3m/s, VDE, CCC, EAC

	pe		Cooling capacity			COP			EER			P1		I		m	
	[°C]	[°F]	[W]	[Btu/h]	[kcal/h]	[W/W]	[Btu/Wh]	[kcal/Wh]	[W]	[A]	[kg/h]	[W]	[A]	[kg/h]	[W]	[A]	[kg/h]
[°C / °F]	-25	-13	290,0	990	249,6	1,07	3,66	0,92	270,3	2,25	6,28	270,3	2,25	6,28	270,3	2,25	6,28
cond. pressure	-20	-4	404,0	1380	347,7	1,27	4,33	1,09	318,8	2,40	8,78	318,8	2,40	8,78	318,8	2,40	8,78
pc= 45/113	-15	5	540,6	1846	465,2	1,47	5,03	1,27	367,3	2,55	11,78	367,3	2,55	11,78	367,3	2,55	11,78
return gas temp.	-10	14	701,6	2396	603,8	1,69	5,78	1,46	414,4	2,70	15,35	414,4	2,70	15,35	414,4	2,70	15,35
RGT= 32/90	0	32	1103,7	3769	949,9	2,21	7,55	1,90	499,5	2,99	24,41	499,5	2,99	24,41	499,5	2,99	24,41
liquid temp	5	41	1348,3	4605	1160,4	2,52	8,61	2,17	534,8	3,13	30,02	534,8	3,13	30,02	534,8	3,13	30,02
Tliq= 45/113	10	50	1624,3	5547	1397,9	2,88	9,84	2,48	563,6	3,25	36,45	563,6	3,25	36,45	563,6	3,25	36,45
[°C / °F]	-25	-13	225,8	771	194,3	0,81	2,77	0,70	278,2	2,30	5,40	278,2	2,30	5,40	278,2	2,30	5,40
cond. pressure	-20	-4	332,9	1137	286,5	1,01	3,45	0,87	329,5	2,44	7,99	329,5	2,44	7,99	329,5	2,44	7,99
pc= 55/131	-15	5	457,6	1563	393,8	1,19	4,08	1,03	383,0	2,61	11,02	383,0	2,61	11,02	383,0	2,61	11,02
return gas temp	-10	14	601,6	2054	517,7	1,38	4,70	1,18	437,4	2,78	14,55	437,4	2,78	14,55	437,4	2,78	14,55
RGT= 32/90	0	32	954,2	3259	821,2	1,75	5,99	1,51	543,7	3,16	23,34	543,7	3,16	23,34	543,7	3,16	23,34
liquid temp	5	41	1166,3	3983	1003,8	1,97	6,72	1,69	592,9	3,35	28,74	592,9	3,35	28,74	592,9	3,35	28,74
Tliq= 55/131	10	50	1404,7	4797	1208,9	2,20	7,52	1,90	637,8	3,55	34,92	637,8	3,55	34,92	637,8	3,55	34,92

Model

Designation	SC15MFX	220-240V/50Hz	Conf. 2	Sales code:	104G8501
-------------	----------------	----------------------	----------------	-------------	-----------------

Configuration

Motorconfiguration	CSIR
Power supply (nominal)	220-240V/50Hz 1~
Refrigerant	R513A
Application	MBP
Voltage range	198-254V
Starting torque	HST
Approvals	VDE CCC EAC

Electrical accessories / wiring diagram

CSIR

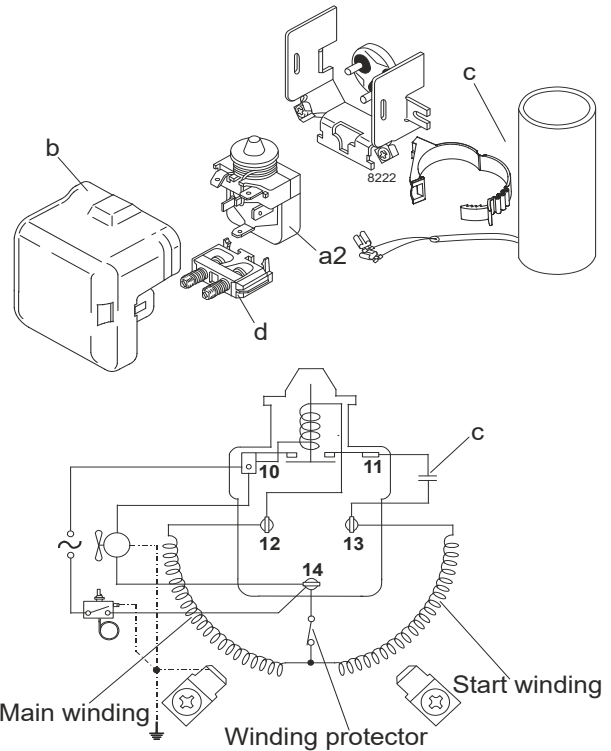

Ambient temperatures / system cooling

Ambient temperature min.:	10°C / 50°F
Ambient temperature max.:	43°C / 110°F

System cooling (n/a: outside limits)			
T ambient	LBP	MBP	HBP
32°C / 90°F	n/a	fan 3m/s	n/a
38°C / 100°F	n/a	fan 3m/s	n/a
43°C / 110°F	n/a	fan 3m/s	n/a

Operation pressure range

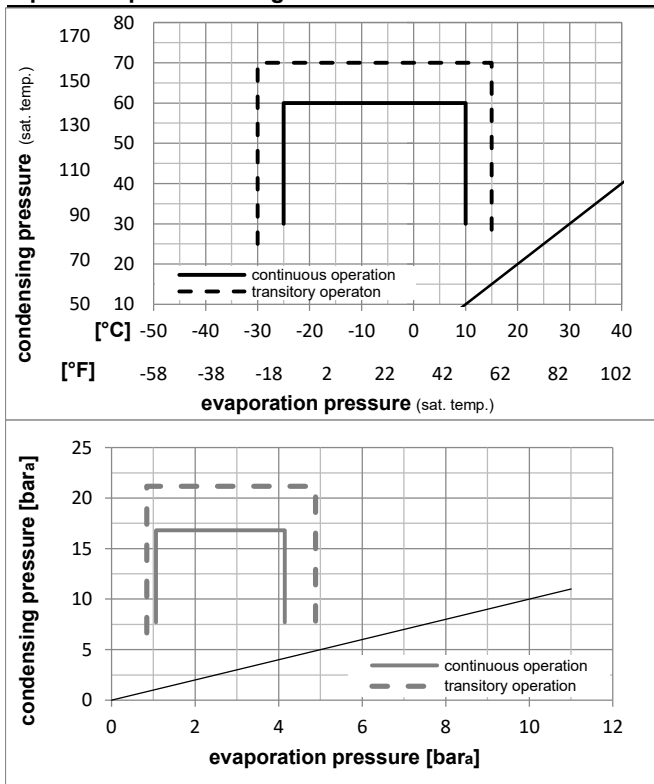

Components

a2	relay	117U6005
c	start capacitor (80µF)	117U5017
d	cord relief	103N1004
b	plastic cover	103N2008

Model

Designation **SC15MFX 220-240V/50Hz** Conf. **2** Sales code: **104G8501**

Optimization + standard conditions

R513A, 220V/50Hz, CSIR, fan 3m/s, VDE, CCC, EAC

Evaporating pressure (saturation temperature)					Condensing pressure (saturation temperature)						Power consumption								
					Return gas temp.			Liquid temp.			Cooling capacity			COP	EER	P1	I	Ref. mass flow	
pe	pc	RGT	Tliq		[W]	[Btu/h]	[kcal/h]	[W/W]	[Btu/Wh]	[kcal/Wh]	[W]	[A]	[kg/h]						
[°C]	-6,7	54,4	35	46,1	826,7	2823	711,5	1,65	5,63	1,42	501,1	3,01	20,25	ASHRAE MBP					
[°F]	20	130	95	115															
[°C]	-10	55	32	55	625,3	2136	538,2	1,34	4,59	1,16	465,2	2,89	17,29	cecmaf MBP					
[°F]	14	131	89,6	131															
[°C]	-10	45	20	45	708,0	2418	609,3	1,61	5,51	1,39	438,7	2,80	18,76	EN12900 MBP					
[°F]	14	113	68	113															
[°C]	-6,7	48,9	18,3	48,9	771,4	2634	663,9	1,59	5,43	1,37	484,8	2,96	21,74	ARI540 MBP					
[°F]	20	120	65	120															
[°C]	-10	45	32	45	740,3	2528	637,1	1,69	5,76	1,45	438,7	2,80	18,20	opt					
[°F]	14	113	89,6	113															
[°C]	-25	45	32	45	317,5	1084	273,2	1,11	3,79	0,95	286,1	2,30	7,74	opt					
[°F]	-13	113	89,6	113															

Performance tables

R513A, 220V/50Hz, CSIR, fan 3m/s, VDE, CCC, EAC

	pe		Cooling capacity			COP	EER	P1			I	m
	[°C]	[°F]	[W]	[Btu/h]	[kcal/h]	[W/W]	[Btu/Wh]	[kcal/Wh]	[W]	[A]	[kg/h]	
[°C / °F]	-25	-13	317,5	1084	273,2	1,11	3,79	0,95	286,1	2,30	7,74	
cond. pressure	-20	-4	435,9	1489	375,2	1,29	4,40	1,11	338,3	2,47	10,65	
pc= 45/113	-15	5	576,3	1968	496,0	1,48	5,05	1,27	389,6	2,64	14,12	
return gas temp.	-10	14	740,3	2528	637,1	1,69	5,76	1,45	438,7	2,80	18,20	
RGT= 32/90	0	32	1145,4	3912	985,8	2,18	7,45	1,88	525,0	3,09	28,41	
liquid temp	5	41	1389,8	4746	1196,0	2,48	8,48	2,14	559,5	3,20	34,66	
Tliq= 45/113	10	50	1664,1	5683	1432,1	2,84	9,69	2,44	586,6	3,29	41,78	
[°C / °F]	-25	-13	245,0	837	210,9	0,82	2,81	0,71	297,3	2,34	6,71	
cond. pressure	-20	-4	354,8	1212	305,4	1,01	3,44	0,87	352,5	2,52	9,74	
pc= 55/131	-15	5	481,1	1643	414,0	1,18	4,02	1,01	408,9	2,71	13,25	
return gas temp	-10	14	625,3	2136	538,2	1,34	4,59	1,16	465,2	2,89	17,29	
RGT= 32/90	0	32	974,5	3328	838,7	1,70	5,81	1,47	572,3	3,24	27,21	
liquid temp	5	41	1182,6	4039	1017,7	1,91	6,51	1,64	620,5	3,40	33,23	
Tliq= 55/131	10	50	1415,1	4833	1217,9	2,13	7,29	1,84	663,2	3,54	40,06	