

SC18CLX.2 LBP Compressor R404A/R507 208-230V 60Hz

General

Code number	104L2172
Approvals	UL984, EN 60335-2-34
Compressors on pallet	80

Application

Application	LBP					
Frequency	Hz	50			60	
Evaporating temperature	°C	-			-45 to -10	
Voltage range	V	-			187 - 254	
Max. condensing temperature continuous (short)	°C	-			55 (60)	
Max. winding temperature continuous (short)	°C	-			125 (135)	

Cooling requirements

Frequency	Hz	50			60		
Application		LBP	MBP	HBP	LBP	MBP	HBP
32°C		-	-	-	F ₂	-	-
38°C		-	-	-	F ₂	-	-
43°C		-	-	-	F ₂	-	-
Remarks on application:							

Motor

Motor type	CSR		
LRA (rated after 4 sec. UL984), HST LST	A	27.3	-
Cut in Current, HST LST	A	27.3	-
Resistance, main start winding (25°C)	Ω	2.6	9.5

Design

Displacement	cm ³	17.68
Oil quantity (type)	cm ³	550 (polyolester)
Maximum refrigerant charge	g	1300
Free gas volume in compressor	cm ³	1460
Weight without electrical equipment	kg	13.9

Dimensions

Height	mm	A	219
		B	213
		B1	193
		B2	110
Suction connector	location/I.D. mm angle	C	9.7 37°
	material comment	Copper Rubber plug	
Process connector	location/I.D. mm angle	D	6.5 37°
	material comment	Copper Rubber plug	
Discharge connector	location/I.D. mm angle	E	6.5 37°
	material comment	Copper Rubber plug	
Oil cooler connector	location/I.D. mm angle	F	-
	material comment	-	
Connector tolerance	I.D. mm	±0.09	
Remarks:			

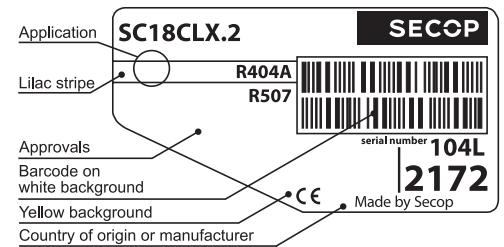

- S = Static cooling normally sufficient
- O = Oil cooling
- F₁ = Fan cooling 1.5 m/s (compressor compartment temperature equal to ambient temperature)
- F₂ = Fan cooling 3.0 m/s necessary
- SG = Suction gas cooling normally sufficient
- = not applicable in this area

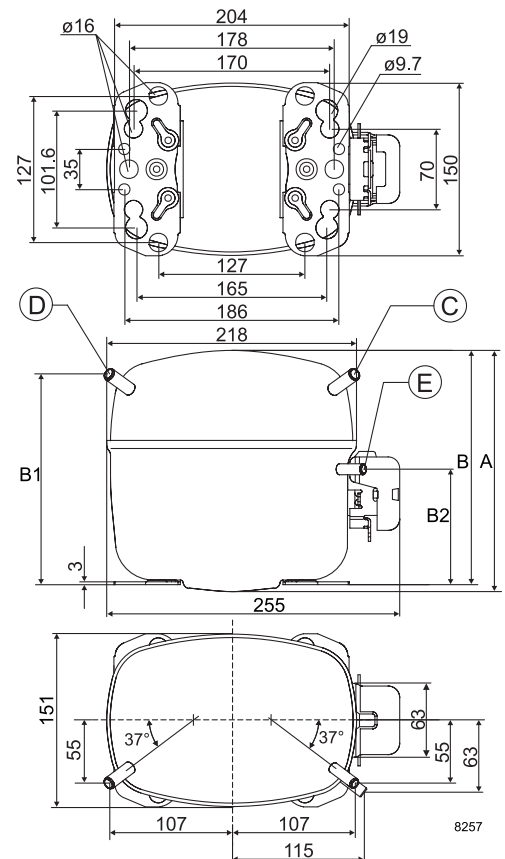

EN 12900 Household (CECOMAF)* 230V, 60Hz, fan cooling F₂

Evap. temp. in °C	-45	-40	-35	-30	-25	-23.3	-20	-15	-10	-6.7	-5	0	5	7.2	10	15	20
Capacity in W	113	338	542	737	938	1010	1157	1410	1708								
Power cons. in W	312	447	563	663	752	780	833	911	990								
Current cons. in A	2.20	2.56	2.92	3.28	3.63	3.75	3.98	4.33	4.67								
COP in W/W	0.36	0.76	0.96	1.11	1.25	1.29	1.39	1.55	1.73								

ASHRAE LBP 230V, 60Hz, fan cooling F₂

Evap. temp. in °C	-45	-40	-35	-30	-25	-23.3	-20	-15	-10	-6.7	-5	0	5	7.2	10	15	20
Capacity in W		225	520	782	1029	1113	1280	1553	1867								
Power cons. in W		398	537	658	765	799	861	951	1038								
Current cons. in A		2.45	2.86	3.27	3.68	3.82	4.09	4.49	4.89								
COP in W/W		0.56	0.97	1.19	1.34	1.39	1.48	1.63	1.80								

ASHRAE LBP* 230V, 60Hz, fan cooling F₂

Evap. temp. in °C	-45	-40	-35	-30	-25	-23.3	-20	-15	-10	-6.7	-5	0	5	7.2	10	15	20
Capacity in W	167	416	644	866	1097	1181	1355	1653	2008								
Power cons. in W	325	455	567	663	749	776	828	904	981								
Current cons. in A	2.23	2.58	2.93	3.28	3.62	3.73	3.96	4.29	4.63								
COP in W/W	0.51	0.91	1.14	1.31	1.47	1.52	1.64	1.83	2.05								

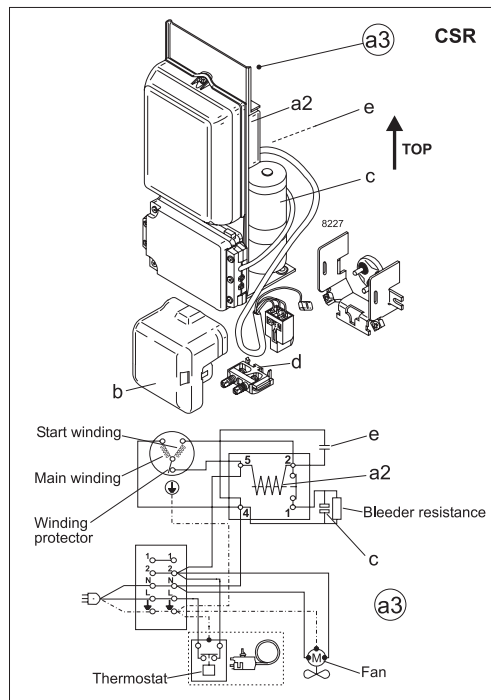

Accessories for	SC18CLX.2 (60 Hz)	Figure	Code number	Test conditions	EN 12900/CECOMAF*	ASHRAE LBP	ASHRAE LBP*
Starting device	585 mm cable length	a3	117-7066	Condensing temperature	45°C	54.4°C	43.3°C
				Ambient temperature	32°C	32°C	32°C
				Suction gas temperature	32°C	32°C	32°C
				Liquid temperature	no subcooling	32°C	32°C
Cover		b	103N2008				
Starting relay	6.3 mm spade connectors	a2	Components of starting device				
Start. capacitor 80 µF	6.3 mm spade connectors	c					
Run capacitor 10 µF	6.3 mm spade connectors	e					
Cord relief		d	103N1004				
Mounting accessories					Code number		
Bolt joint for one comp.					Ø: 16 mm	118-1917	
Bolt joint in quantities					Ø: 16 mm	118-1918	
Snap-on in quantities					Ø: 16 mm	118-1919	

Secop accepts no responsibility for possible errors in catalogs, brochures, and other printed material. Secop reserves the right to alter its products without notice. This also applies to products already on order provided that such alterations can be made without subsequential changes being necessary to specifications already agreed. All trademarks in this material are the property of the respective companies. Secop and the Secop logotype are trademarks of Secop GmbH. All rights reserved. www.secop.com