

Model

Designation	SC18CLX.2	220-240V/50Hz 1~	Sales code:	104L2191
-------------	------------------	------------------	-------------	-----------------

Compressor design

Oil type	Polyolester	Refrigerant(s)	R404A, R507
Oil viscosity	32cST	Displacement	17,69cm ³ / 1,08cu.in
Oil quantity	600cm ³ / 20,3fl.oz	Compressors on pallet	80
Refr. charge - tech. limit	1300g / 45,9oz		
Free gas volume comp.	1460cm ³ / 49,4fl.oz		
Weight	13,8kg / 30,4lbs		
Motor protection	1# internal		
Winding resistance main	3,3Ω (at 25°C)		
Winding resistance aux	16,5Ω (at 25°C)		
Max. winding temp.	125°C / 257°F		
Max. discharge temp.	130°C / 266°F		



General - Configurations with SC18CLX.2

	Conf. 1
Motorconfiguration	CSIR
Power supply (nominal)	208-240V/50Hz
Number of phases	1
Voltage range	198-254V
Approvals	VDE, CCC, EAC
Starting torque	HST
Note	Compressor with noise optimization kit.

Applications with SC18CLX.2

	Conf. 1
Refrigerant	R404A
Application	LBP
System cooling	fan 3m/s
Hot gas defrost	OK
Long interval pull down	OK

Electrical data - Configurations with SC18CLX.2

	Conf. 1
Starting device type	relay
Run capacitor	-/-
Start capacitor	125μF
LRA (locked rotor amps / 4s)	23,5A
RLA (rated load amps / 1s)	4,5A
Cut in current	23,5A
IP class	21

Model

Designation	SC18CLX.2	220-240V/50Hz 1~	Sales code:	104L2191
-------------	------------------	------------------	-------------	-----------------

Compressor dimensions

Housing	A Height	219mm / 8,62in
	B Height	213mm / 8,39in
	C Length shell	218mm / 8,58in
	D Length w. cover	255mm / 10,04in
	E Width	151mm / 5,94in

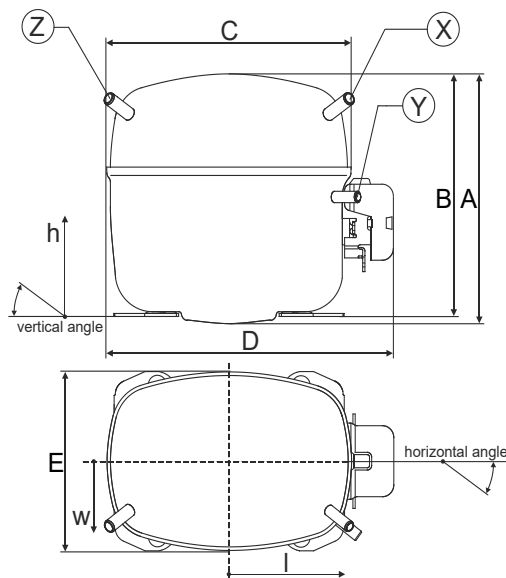

Connectors		Suction	Discharge	Process
		X	Y	Z
Diameter	[mm]	øi 10,11-10,29	øi 6,11-6,29	øi 6,11-6,29
(i:inside, o:outside)	[in]	øi 0,4-0,41	øi 0,24-0,25	øi 0,24-0,25
Material		copper	copper	copper
Horizontal angle	±2°	37°	37°	143°
Vertical angle	±2°	30°	0°	150°
Position l/h/w	[mm]	107/193/55	115/110/63	-107/193/55
	[in]	4,2/7,6/2,2	4,5/4,3/2,5	-4,2/7,6/2,2
Straight tube l.	[mm]	12	12	12
	[in]	0,5	0,5	0,5

Compressor fixation

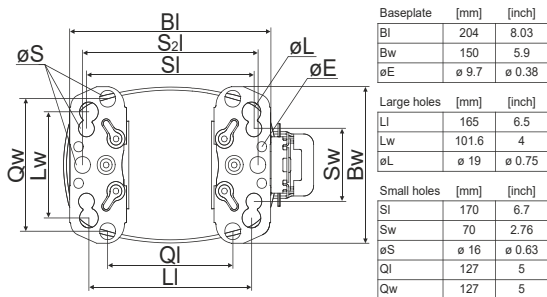

Bolt joint

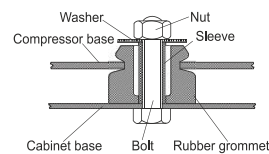

Snap-on

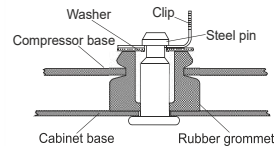

Mounting accessories	one comp.	multi pack
Bolt joint M6 ø16mm	118-1917	118-1918
Bolt joint ø1/4" ø16mm	118-1946	
Bolt joint ø1/4" ø19mm	118-1949	
Snap-on ø7,3 ø16mm	118-1947	118-1919

Model

Designation	SC18CLX.2	208-240V/50Hz	Conf. 1	Sales code:	104L2191
-------------	------------------	----------------------	----------------	-------------	-----------------

Configuration

Motorconfiguration	CSIR
Power supply (nominal)	208-240V/50Hz 1~
Refrigerant	R404A
Application	LBP
Voltage range	198-254V
Starting torque	HST
Approvals	VDE CCC EAC

Electrical accessories / wiring diagram

CSIR

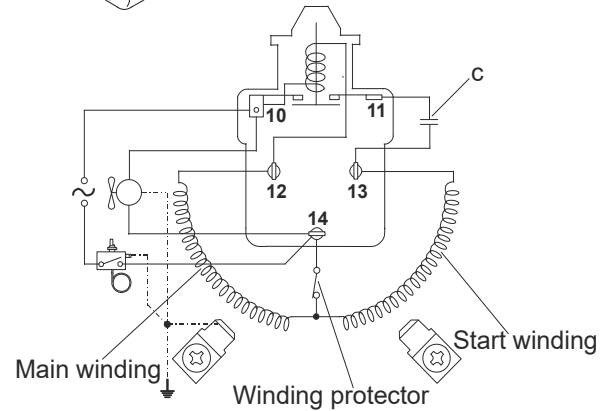
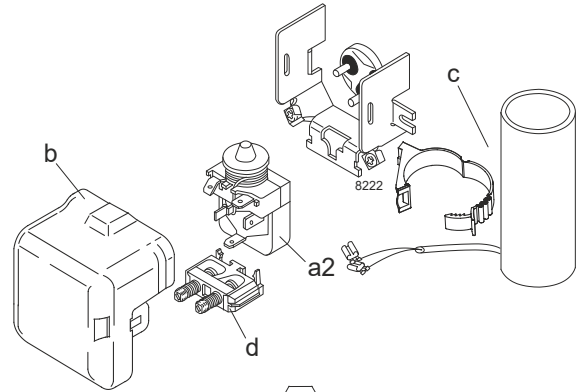

Ambient temperatures / system cooling

Ambient temperature min.:	10°C / 50°F
Ambient temperature max.:	38°C / 101°F

System cooling (n/a: outside limits)			
T ambient	LBP	MBP	HBP
32°C / 90°F	fan 3m/s	n/a	n/a
38°C / 100°F	fan 3m/s	n/a	n/a
43°C / 110°F	n/a	n/a	n/a

Operation pressure range

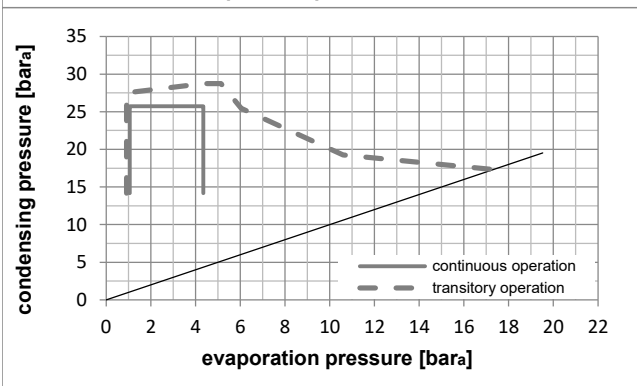
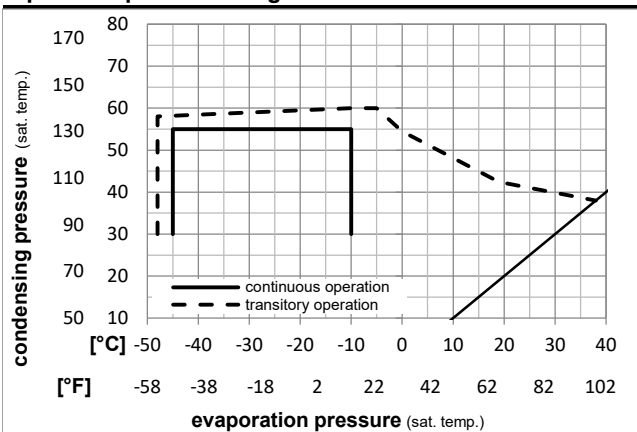

Components

a2	relay	117U6013
c	start capacitor (125µF)	117U5012
d	cord relief	103N1004
b	plastic cover	103N2009

Model

Designation	SC18CLX.2	208-240V/50Hz	Conf. 1	Sales code:	104L2191
-------------	------------------	----------------------	----------------	-------------	-----------------

Optimization + standard conditions

R404A, 220V/50Hz, CSIR, fan 3m/s, VDE, CCC, EAC

		Evaporating pressure (saturation temperature)				Condensing pressure (saturation temperature)						Power consumption					
						Return gas temp.						Current consumption					
						Liquid temp.						Ref. mass flow					
						Cooling capacity						COP	EER	P1	I	m	
		pe	pc	RGT	Tliq	[W]	[Btu/h]	[kcal/h]	[W/W]	[Btu/Wh]	[kcal/Wh]	[W]	[A]	[kg/h]			
[°C]	-23,3	54,4	32,2	32,2	854,8	2919	735,7	1,24	4,23	1,07	690,0	4,29	19,92	ASHRAE LBP			
[°F]	-10	130	90	90													
[°C]	-25	55	32	55	576,8	1970	496,4	0,88	3,00	0,76	656,4	4,18	18,03	cecomaf LBP			
[°F]	-13	131	89,6	131													
[°C]	-35	40	20	40	438,0	1496	376,9	0,89	3,03	0,76	493,9	3,54	11,90	EN12900 LBP			
[°F]	-31	104	68	104													
[°C]	-23,3	48,9	4,44	48,9	638,2	2179	549,2	0,94	3,20	0,81	680,7	4,25	22,59	ARI540 LBP			
[°F]	-10	120	40	120													
[°C]	-23,3	40,6	32,2	32,2	960,4	3280	826,5	1,47	5,03	1,27	651,6	4,17	22,38	AHAM LBP			
[°F]	-10	105	90	90													
[°C]	-35	45	32	45	397,5	1358	342,1	0,81	2,76	0,70	491,4	3,54	10,63	opt			
[°F]	-31	113	89,6	113													

Performance tables

R404A, 220V/50Hz, CSIR, fan 3m/s, VDE, CCC, EAC

	pe	Cooling capacity				COP	EER	P1	I	m	
	[°C]	[°F]	[W]	[Btu/h]	[kcal/h]	[W/W]	[Btu/Wh]	[kcal/Wh]	[W]	[A]	[kg/h]
[°C / °F]	-45	-49	108,1	369	93,1	0,27	0,93	0,23	397,2	3,01	2,87
cond. pressure	-35	-31	397,5	1358	342,1	0,81	2,76	0,70	491,4	3,54	10,63
pc= 45/113	-30	-22	558,6	1908	480,7	1,00	3,41	0,86	559,6	3,83	14,99
return gas temp.	-25	-13	738,1	2521	635,2	1,16	3,94	0,99	639,0	4,12	19,91
RGT= 32/90	-20	-4	941,7	3216	810,4	1,29	4,42	1,11	727,5	4,42	25,55
liquid temp	-15	5	1174,9	4012	1011,1	1,43	4,88	1,23	823,0	4,73	32,09
Tliq= 45/113	-10	14	1443,4	4929	1242,2	1,56	5,34	1,35	923,4	5,06	39,75
[°C / °F]	-45	-49	11,6	40	10,0	0,04	0,12	0,03	325,0	2,89	0,36
cond. pressure	-35	-31	280,6	958	241,5	0,60	2,03	0,51	471,1	3,51	8,68
pc= 55/131	-30	-22	422,5	1443	363,6	0,75	2,58	0,65	559,9	3,84	13,13
return gas temp	-25	-13	576,8	1970	496,4	0,88	3,00	0,76	656,4	4,18	18,03
RGT= 32/90	-20	-4	749,1	2558	644,7	0,99	3,37	0,85	758,4	4,52	23,57
liquid temp	-15	5	945,2	3228	813,4	1,09	3,74	0,94	864,0	4,88	29,97
Tliq= 55/131	-10	14	1170,4	3997	1007,3	1,21	4,12	1,04	970,8	5,24	37,47