

Model

Designation	SLVE18CN	Sales code:	104H8845
-------------	-----------------	-------------	-----------------

Compressor design

Oil type	Polyolester	Refrigerant(s)	R290
Oil viscosity	32cSt	Displacement	17,69cm ³ / 1,08cu.in
Oil quantity	555cm ³ / 18,8fl.oz	Compressors on pallet	80
Refr. charge - tech. limit	550g / 19,4oz		
Free gas volume comp.	1460cm ³ / 49,4fl.oz		
Weight	14,2kg / 31,3lbs		
Motor protection	2# internal		
Winding resist. ph. to ph.	3,92Ω (at 25°C)		
Max. winding temp.	125°C / 257°F		
Max. discharge temp.	130°C / 266°F		



General - Configurations and Applications with SLVE18CN and Controller

Conf. 1

Sales code single pack:	105N4932
Sales code industry pack:	105N4933
Power supply (nominal)	100–240 V,50/60 Hz
Approvals	VDE,UL,CCC
Refrigerant	R290
Number of phases	1~AC
Application	L+MBP
Starting torque	HST
Hot gas defrost	OK
Long interval pull down	OK
System cooling	Fan cooling 3m/s
Note	See operation limits for controller

Controller functions

Conf. 1

Protection	Mechanic
Max output power	1100 W
No of relays	2
Hot gas defrost	yes
AEO speed setting	yes
Serial com, (Modbus)	SWI
DWI / Frequency input	yes
Reduced leakage current	yes
Note	

Model

Designation

SLVE18CN

Sales code:

104H8845

Compressor dimensions

Housing	A Height	219mm / 8,62in
	B Height	213mm / 8,39in
	C Length shell	218mm / 8,58in
	D Length w. cover	255mm / 10,04in
	E Width	151mm / 5,94in

Connectors		Suction	Discharge	Process
		X	Y	Z
Diameter	[mm]	øi 9,54-9,72	øi 6,41-6,59	øi 6,41-6,59
(i:inside, o:outside)	[in]	øi 0,38-0,38	øi 0,25-0,26	øi 0,25-0,26
Material		copper	copper	copper
Horizontal angle	±2°	37°	37°	37°
Vertical angle	±2°	30°	0°	30°
Position l/h/w	[mm]	-106/193/57	114/110/81	106/94/72
	[in]	-4,2/7,6/2,2	4,5/4,3/3,2	4,2/3,7/2,8
Straight tube l.	[mm]	12	12	12
	[in]	0,5	0,5	0,5

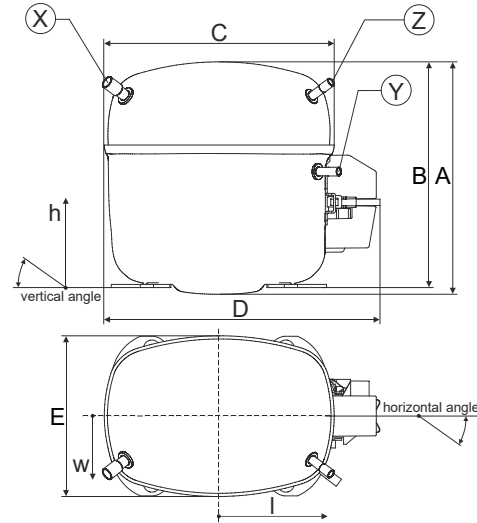

Compressor fixation

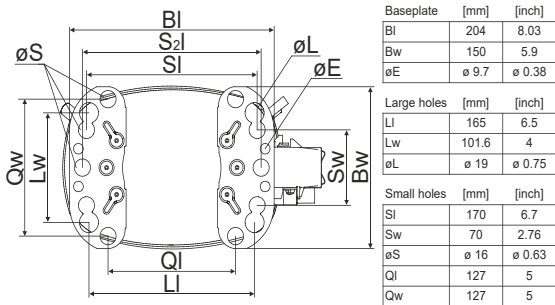

Bolt joint

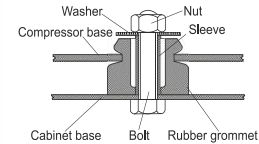

Snap-on

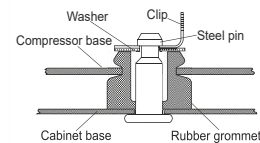

Mounting accessories

Bolt joint | M6 | ø16mm

Snap-on | ø7,3 | ø16mm

one comp. multi pack

118-1958 118-1961

118-1962

Application notes

Operation possible until tilted up to 3 degrees

Provision for PE Grounding is located at the PE Stamp on the compressor

QR Code and Hyperlink leads to the

[Operating Instructions.](#)



Model

Designation **SLVE18CN** **100–240 V,50/60 Hz** **Conf. 1** Sales code: **104H8845**

Controller **SLVE MP MV GFCI** **105N4932**

Sales code single pack: 105N4932 (1 units)
 Sales code industry pack: 105N4933 (8 units)
 Adaption to compressor: detached
 Protection class: IP54
 Weight: 1.4 kg/3.08 lbs
 Voltage nom.: 100–240 V,50/60 Hz
 Voltage range: 90–150/180–270 V
 Max. current: 4,2 A(230V)/8,4 A(115V)
 LRA (Locked Rotor Amperage), 2,9 A
 Cable length: 915 mm
 Compressor speed range: 2200-4500rpm
 Housing plastic: UL94-5VA

Controller dimensions:

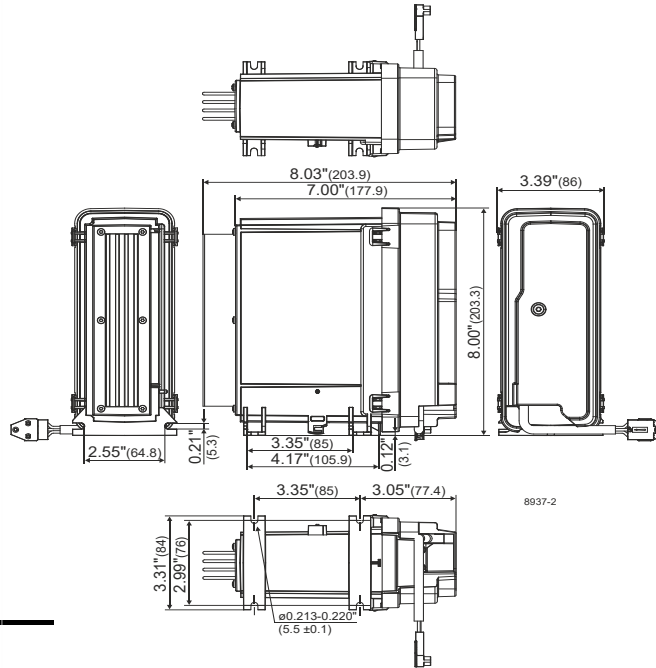

Operation Limits

U:100-240V LBP; 208-240V MBP; 50/60Hz

System cooling

Ambient/ machineroom temperatures minimum /maximum

Ambient temperature range: 10 - 43°C / 50 - 110°F
 Machine room temperature range compressor: 10 - 48°C / 50 - 119°F
 Machine room temperature range controller: 10 - 50°C / 50 - 122°F

Compressor and Controller Cooling: Fan cooling 3m/s

Ensure proper airflow of 3 m/s at both compressor and electronic units.

The airflow for the electronics must be directed to the heat sink.

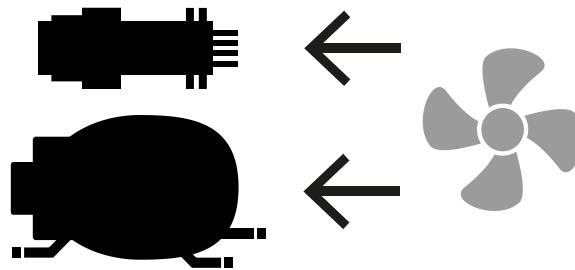

Operation pressure range

R290

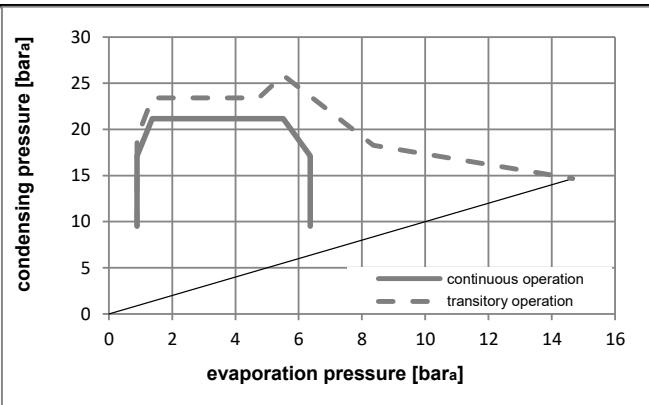
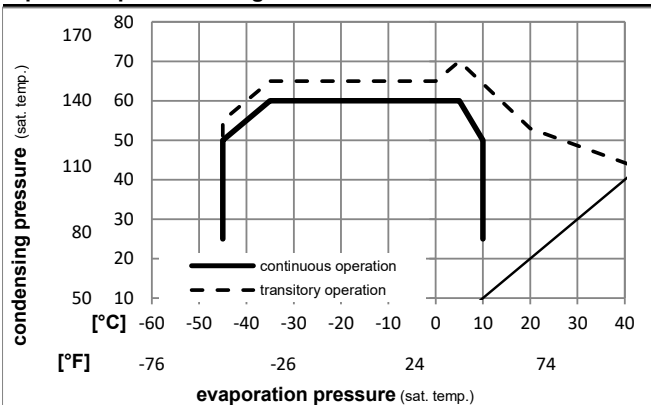

Model

Designation **SLVE18CN** **100–240 V,50/60 Hz** **Conf. 1** Sales code: **104H8845**

Controller **SLVE MP MV GFCI** **105N4932**

Controller connections

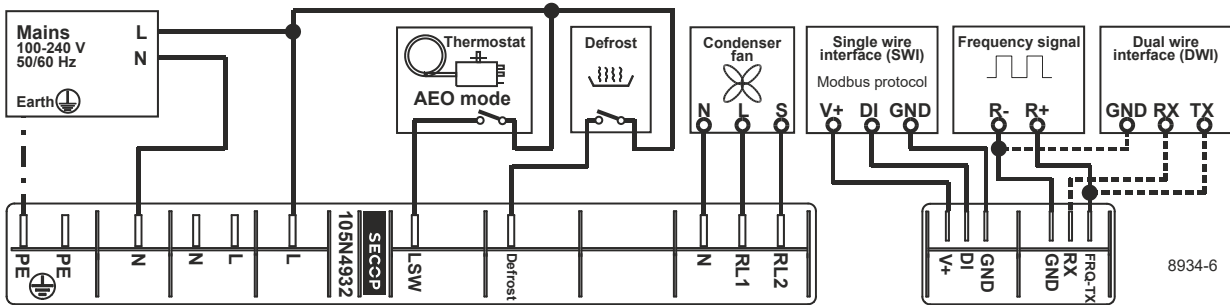
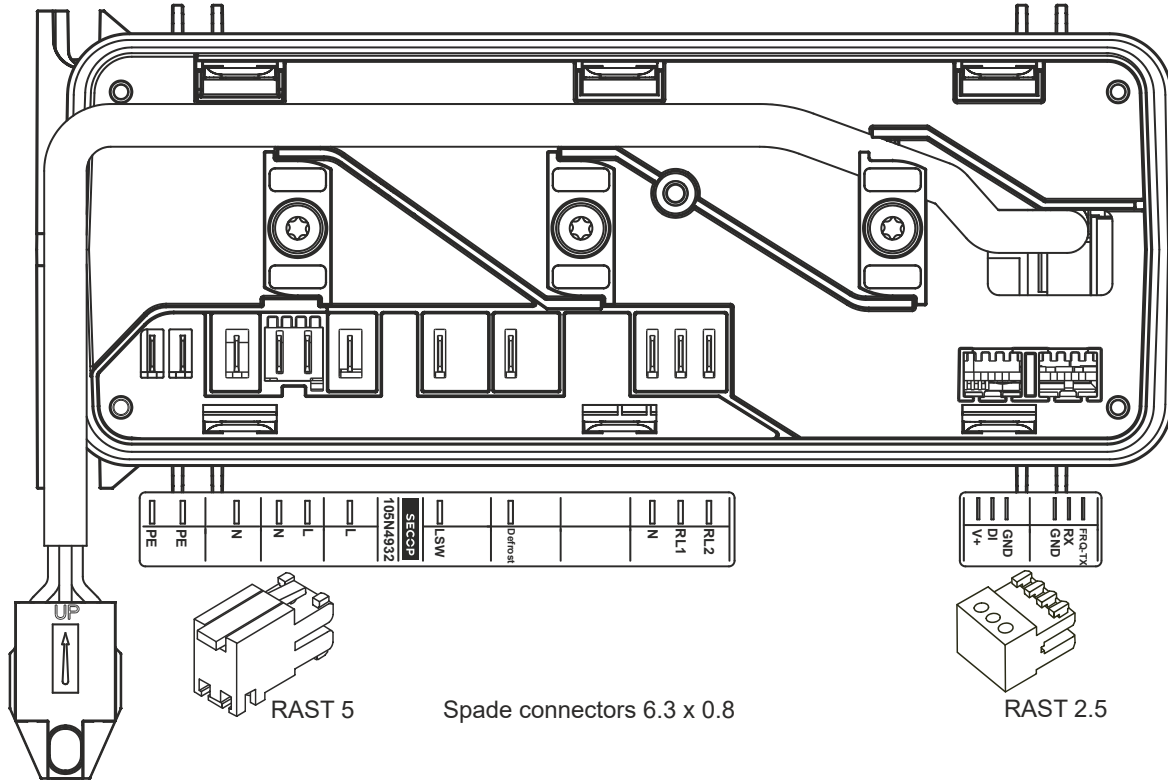

Accessories (Compressor + Controller) - check operation manual for details

103N2008 plastic cover 1 pcs

Model

Designation **SLVE18CN** **100-240 V,50/60 Hz** **Conf. 1** Sales code: **104H8845**

Controller **SLVE MP MV GFCI** **105N4932**

Optimization + standard conditions

R290, 220V, 50Hz, Rpm_N 4500, Fan cooling 3m/s

	Evaporating pressure (saturation temperature)				Condensing pressure (saturation temperature)			Return gas temp.			Liquid temp.			Cooling capacity			COP	EER	P1	Power consumption		Ref. mass flow	
	pe	pc	RGT	Tliq	[W]	[Btu/h]	[kcal/h]	[W/W]	[Btu/Wh]	[kcal/Wh]	[W]	I	m	[A]	[kg/h]								
[°C]	-23	54	32	32	1190,1	4065	1024,3	1,67	5,69	1,43	713,9	3,88	12,05	ASHRAE LBP									
[°F]	-10	130	90	90																			
[°C]	-25	55	32	55	888,8	3035	764,9	1,29	4,42	1,11	687,2	3,73	11,07	cecomaf LBP									
[°F]	-13	131	90	131																			
[°C]	-35	40	20	40	646,9	2209	556,7	1,33	4,56	1,15	484,8	2,63	7,39	EN12900 LBP									
[°F]	-31	104	68	104																			
[°C]	-7	54	35	46	2149,0	7339	1849,4	2,14	7,30	1,84	1004,9	5,46	24,51	ASHRAE MBP									
[°F]	20	130	95	115																			
[°C]	-10	55	32	55	1707,6	5832	1469,6	1,79	6,10	1,54	956,6	5,20	21,60	cecomaf MBP									
[°F]	14	131	90	131																			
[°C]	-10	45	20	45	1868,3	6381	1607,9	2,18	7,43	1,87	858,9	4,67	22,94	EN12900 MBP									
[°F]	14	113	68	113																			

Standard conditions with different RPM

R290, 220V, 50Hz, Rpm_N 4500, Fan cooling 3m/s

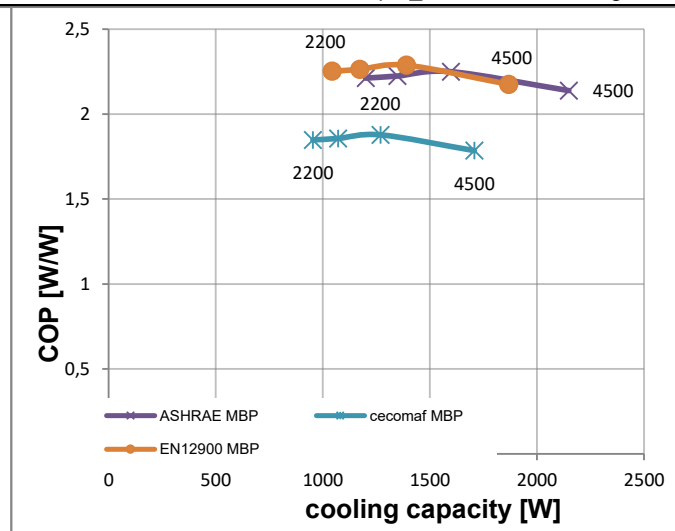
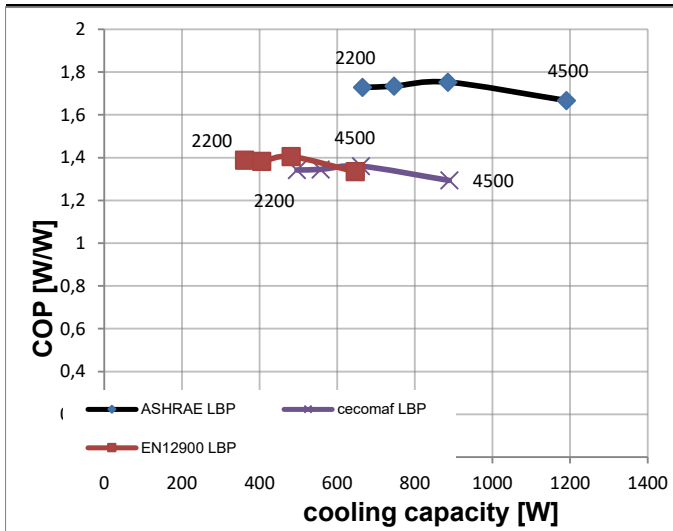

Test conditions:	pe [°C]	pc [°C]	Tliq [°C]	Tsuc [°C]
ASHRAE LBP	-23	54,44	32,22	32,22
cecomaf LBP	-25	55	55	32
EN12900 LBP	-35	40	40	20

Test conditions:	pe [°C]	pc [°C]	Tliq [°C]	Tsuc [°C]
ASHRAE MBP	-6,66	54,44	46,11	35
cecomaf MBP	-10	55	55	32
EN12900 MBP	-10	45	45	20