

Model

Designation	GS34CLX	220-240V/50Hz 1~	Sales code:	107B0525
-------------	----------------	------------------	-------------	-----------------

Compressor design

Oil type	Polyolester	Refrigerant(s)	R404A, R507, R452A
Oil viscosity	46cST	Displacement	33,8cm ³ / 2,06cu.in
Oil quantity	906cm ³ / 30,6fl.oz	Compressors on pallet	48
Refr. charge - tech. limit	2000g / 70,5oz		
Free gas volume comp.	3350cm ³ / 113,3fl.oz		
Weight	20kg / 44,1lbs		
Motor protection	1# internal		
Winding resistance main	1,6Ω (at 25°C)		
Winding resistance aux	6,7Ω (at 25°C)		
Max. winding temp.			
Max. discharge temp.	130°C / 266°F		



General - Configurations with GS34CLX

	Conf. 1	Conf. 2
Motorconfiguration	CSCR	CSCR
Power supply (nominal)	220-240V/50Hz	220-240V/50Hz
Number of phases	1	1
Voltage range	198-254V	198-254V
Approvals	VDE, EAC	VDE, EAC
Starting torque	HST	HST
Note	Cover, clamp, gasket: pre-assembled to compressor.	

Applications with GS34CLX

	Conf. 1	Conf. 2
Refrigerant	R404A	R452A
Application	LBP	LBP
System cooling	fan 3m/s	fan 3m/s
Hot gas defrost	OK	OK
Long interval pull down	OK	OK

Electrical data - Configurations with GS34CLX

	Conf. 1	Conf. 2
Starting device type	relay	relay
Run capacitor	15μF	15μF
Start capacitor	100μF	100μF
LRA (locked rotor amps / 4s)	40A	40A
RLA (rated load amps / 1s)	5,6A	5,6A
Cut in current	40A	40A
IP class	21	21

Model

Designation	GS34CLX	220-240V/50Hz 1~	Sales code:	107B0525
-------------	----------------	------------------	-------------	-----------------

Compressor dimensions

Housing	A Height	279mm / 10,98in
	B Height	267mm / 10,51in
	C Length shell	224mm / 8,82in
	D Length w. cover	232mm / 9,13in
	E Width	173mm / 6,81in

Connectors		Suction	Discharge	Process
		X	Y	Z
Diameter	[mm]	øi 12,75-13,05	øi 8,15-8,25	øi 6,4-6,6
(i:inside, o:outside)	[in]	øi 0,5-0,51	øi 0,32-0,32	øi 0,25-0,26
Material		copper	copper	copper
Horizontal angle	±2°	0°	0°	0°
Vertical angle	±2°	90°	71°	90°
Position l/h/w	[mm]	-95/234/-84	-105/84/-84	95/234/84
	[in]	-3,7/9,2/-3,3	-4,1/3,3/-3,3	3,7/9,2/3,3
Straight tube l.	[mm]	18	23	15
	[in]	0,7	0,9	0,6

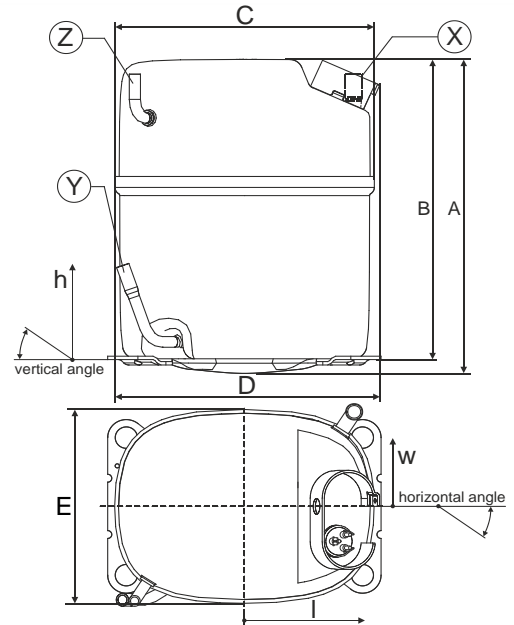

Compressor fixation

Bolt joint

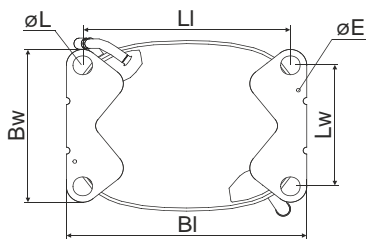

Baseplate	[mm]	[inch]
BI	235	9.25
Bw	154	6.06
øE	ø 3.6	ø 0.14
Large holes	[mm]	[inch]
LI	203	7.99
Lw	122	4.80
øL	ø 19	ø 0.75

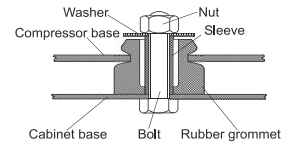

Mounting accessories

Bolt joint | M8 | ø19mm one comp. 107B9150

Model

Designation	GS34CLX	220-240V/50Hz	Conf. 1	Sales code:	107B0525
-------------	----------------	----------------------	----------------	-------------	-----------------

Configuration

Motorconfiguration	CSCR
Power supply (nominal)	220-240V/50Hz 1~
Refrigerant	R404A
Application	LBP
Voltage range	198-254V
Starting torque	HST
Approvals	VDE EAC

Electrical accessories / wiring diagram

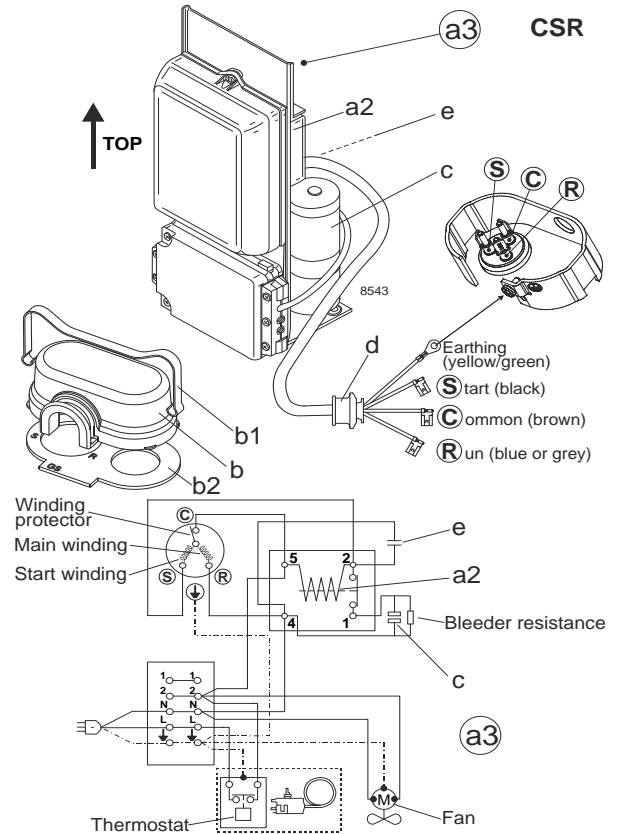

Ambient temperatures / system cooling

Ambient temperature min.:	10°C / 50°F
Ambient temperature max.:	38°C / 101°F

System cooling (n/a: outside limits)			
T ambient	LBP	MBP	HBP
32°C / 90°F	fan 3m/s	n/a	n/a
38°C / 100°F	fan 3m/s	n/a	n/a
43°C / 110°F	n/a	n/a	n/a

Operation pressure range

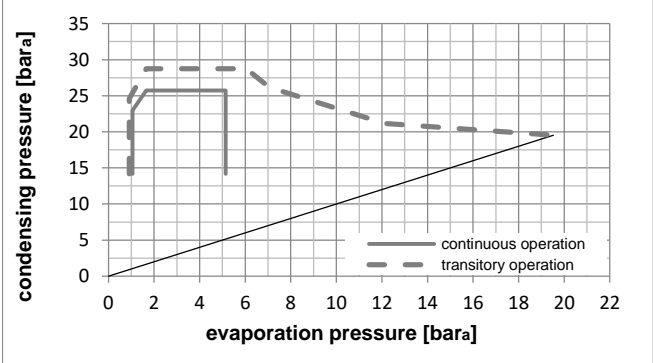
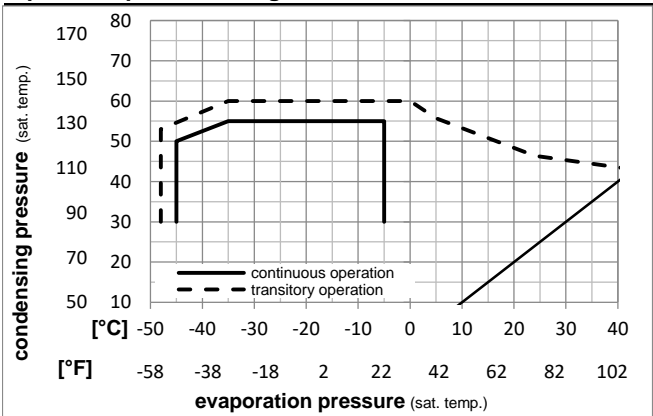

Components (cover, clamp, gasket: pre assembled)

a3	GS starter kit	117-7074
b	cover	107B9101
b2	gasket	107B9100
b1	clamp	107B9104

Model

Designation **GS34CLX 220-240V/50Hz** Conf. 1 Sales code: **107B0525**

Optimization + standard conditions

R404A, 220V/50Hz, CSCR, fan 3m/s, VDE, EAC

Evaporating pressure (saturation temperature)														
Condensing pressure (saturation temperature)														
Return gas temp.														
Liquid temp.														
Cooling capacity														
COP														
EER														
Power consumption														
Current consumption														
Ref. mass flow														
	pe	pc	RGT	Tliq	[W]	[Btu/h]	[kcal/h]	[W/W]	[Btu/Wh]	[kcal/Wh]	P1	I	m	
[°C]	[°C]	[°C]	[°C]	[°C]	[W]	[Btu/h]	[kcal/h]	[W/W]	[Btu/Wh]	[kcal/Wh]	[W]	[A]	[kg/h]	
[°F]	-23,3	54,4	32,2	32,2	1912,6	6532	1646,0	1,44	4,93	1,24	1323,9	6,83	44,56	ASHRAE LBP
[°F]	-10	130	90	90										
[°C]	-25	55	32	55	1295,8	4425	1115,2	1,03	3,51	0,88	1262,1	6,58	40,50	cecomaf LBP
[°F]	-13	131	89,6	131										
[°C]	-35	40	20	40	1003,5	3427	863,6	1,09	3,71	0,93	924,5	4,93	27,27	EN12900 LBP
[°F]	-31	104	68	104										
[°C]	-23,3	48,9	4,44	48,9	1412,2	4823	1215,4	1,08	3,69	0,93	1306,7	6,57	50,00	ARI540 LBP
[°F]	-10	120	40	120										
[°C]	-23,3	40,6	32,2	32,2	2120,8	7243	1825,2	1,70	5,79	1,46	1250,5	6,29	49,42	AHAM LBP
[°F]	-10	105	90	90										
[°C]	-35	45	32	45	935,7	3195	805,2	1,01	3,43	0,86	930,9	4,92	25,01	opt
[°F]	-31	113	89,6	113										

Performance tables

R404A, 220V/50Hz, CSCR, fan 3m/s, VDE, EAC

	pe	Cooling capacity			COP	EER	P1	I	m			
		[°C]	[°F]	[W]						[Btu/h]	[kcal/h]	[W/W]
[°C / °F]	-45	-49		437,8	1495	376,7	0,71	2,42	0,61	618,4	3,91	11,63
cond. pressure	-35	-31		935,7	3195	805,2	1,01	3,43	0,86	930,9	4,92	25,01
pc= 45/113	-30	-22		1257,0	4293	1081,8	1,16	3,98	1,00	1079,3	5,52	33,74
return gas temp.	-25	-13		1636,5	5589	1408,4	1,33	4,54	1,14	1231,5	6,19	44,14
RGT= 32/90	-20	-4		2081,9	7110	1791,7	1,49	5,10	1,28	1394,4	6,92	56,48
liquid temp	-15	5		2601,0	8883	2238,4	1,65	5,64	1,42	1574,8	7,72	71,05
Tliq= 45/113	-5	23		3893,8	13298	3351,0	1,93	6,60	1,66	2015,7	9,51	108,25
[°C / °F]	-45	-49		264,6	904	227,7	0,54	1,85	0,47	489,3	3,73	8,13
cond. pressure	-35	-31		696,3	2378	599,3	0,78	2,67	0,67	892,0	5,02	21,54
pc= 55/131	-30	-22		971,3	3317	835,9	0,90	3,08	0,78	1077,7	5,77	30,19
return gas temp	-25	-13		1295,8	4425	1115,2	1,03	3,51	0,88	1262,1	6,58	40,50
RGT= 32/90	-20	-4		1677,5	5729	1443,7	1,16	3,95	0,99	1452,0	7,45	52,78
liquid temp	-15	5		2124,6	7256	1828,5	1,28	4,39	1,11	1654,3	8,39	67,38
Tliq= 55/131	-5	23		3249,1	11096	2796,2	1,53	5,23	1,32	2123,4	10,46	105,17

Model

Designation	GS34CLX	220-240V/50Hz	Conf. 2	Sales code:	107B0525
-------------	----------------	----------------------	----------------	-------------	-----------------

Configuration

Motorconfiguration	CSCR
Power supply (nominal)	220-240V/50Hz 1~
Refrigerant	R452A
Application	LBP
Voltage range	198-254V
Starting torque	HST
Approvals	VDE EAC

Electrical accessories / wiring diagram

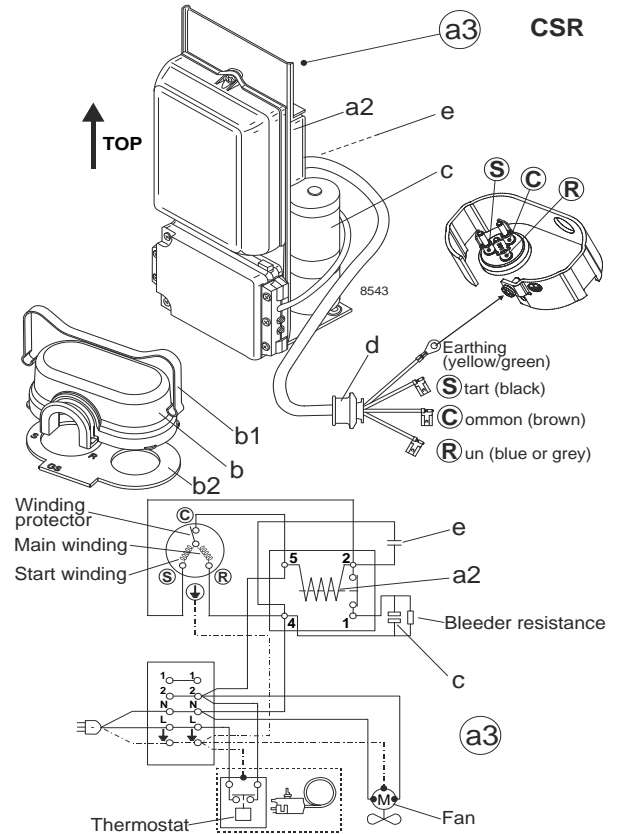

Ambient temperatures / system cooling

Ambient temperature min.:	10°C / 50°F
Ambient temperature max.:	38°C / 101°F

System cooling (n/a: outside limits)			
T ambient	LBP	MBP	HBP
32°C / 90°F	fan 3m/s	n/a	n/a
38°C / 100°F	fan 3m/s	n/a	n/a
43°C / 110°F	n/a	n/a	n/a

Operation pressure range

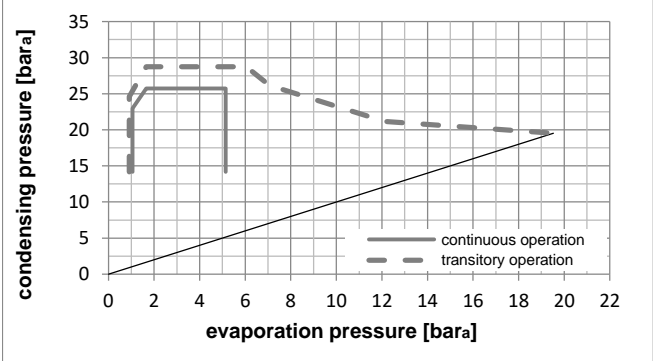
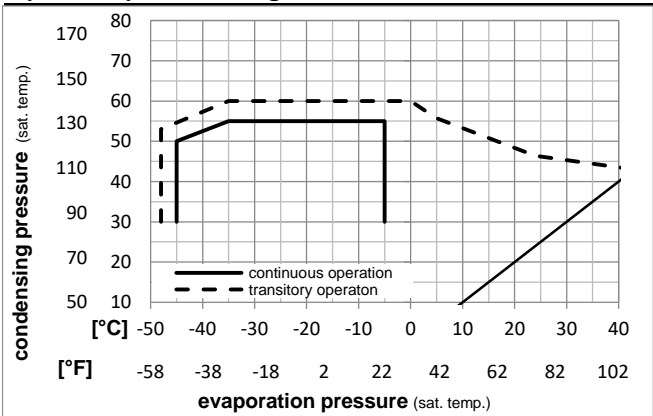

Components (cover, clamp, gasket: pre assembled)

a3	GS starter kit	117-7074
b	cover	107B9101
b2	gasket	107B9100
b1	clamp	107B9104

Model

Designation **GS34CLX 220-240V/50Hz** Conf. 2 Sales code: **107B0525**

Optimization + standard conditions

R452A, 220V/50Hz, CSCR, fan 3m/s, VDE, EAC

Evaporating pressure (saturation temperature)					Condensing pressure (saturation temperature)						Power consumption				
					Return gas temp.			Liquid temp.			Current consumption			Ref. mass flow	
					Cooling capacity			COP	EER	P1			I	m	
	pe	pc	RGT	Tliq	[W]	[Btu/h]	[kcal/h]	[W/W]	[Btu/Wh]	[kcal/Wh]	[W]	[A]	[kg/h]		
[°C]	-23	54,4	32,2	32,2	1850,2	6319	1592,3	1,51	5,15	1,30	1227,1	5,56	44,47	ASHRAE LBP	
[°F]	-10	130	90	90											
[°C]	-25	55	32	55	1257,8	4295	1082,4	1,08	3,68	0,93	1168,3	5,39	40,02	cecmaf LBP	
[°F]	-13	131	89,6	131											
[°C]	-35	40	20	40	933,9	3189	803,7	1,10	3,75	0,95	849,8	4,43	26,08	EN12900 LBP	
[°F]	-31	104	68	104											
[°C]	-23	48,9	4,44	48,9	1382,0	4720	1189,4	1,14	3,89	0,98	1214,2	5,52	49,68	ARI540 LBP	
[°F]	-10	120	40	120											
[°C]	-23	40,6	32,2	32,2	2048,0	6994	1762,6	1,76	6,00	1,51	1165,5	5,38	49,23	AHAM LBP	
[°F]	-10	105	90	90											
[°C]	-35	45	32	45	869,0	2968	747,9	1,02	3,48	0,88	852,5	4,44	23,85	opt	
[°F]	-31	113	89,6	113											

Performance tables

R452A, 220V/50Hz, CSCR, fan 3m/s, VDE, EAC

	pe	Cooling capacity			COP	EER	P1			I	m
	[°C]	[°F]	[W]	[Btu/h]	[kcal/h]	[W/W]	[Btu/Wh]	[kcal/Wh]	[W]	[A]	[kg/h]
[°C / °F]	-45	-49	447,0	1527	384,7	0,86	2,93	0,74	520,2	3,44	12,20
cond. pressure	-35	-31	869,0	2968	747,9	1,02	3,48	0,88	852,5	4,44	23,85
pc= 45/113	-30	-22	1186,9	4053	1021,4	1,19	4,06	1,02	999,1	4,88	32,69
return gas temp.	-25	-13	1578,9	5392	1358,8	1,38	4,71	1,19	1144,9	5,32	43,68
RGT= 32/90	-20	-4	2047,4	6992	1762,0	1,58	5,38	1,36	1298,9	5,78	56,93
liquid temp	-15	5	2595,1	8863	2233,3	1,77	6,03	1,52	1470,3	6,29	72,60
Tliq= 45/113	-5	23	3940,1	13456	3390,9	2,07	7,08	1,78	1901,7	7,59	111,96
[°C / °F]	-45	-49	297,7	1017	256,2	0,75	2,56	0,64	397,5	3,07	9,33
cond. pressure	-35	-31	644,0	2199	554,2	0,79	2,71	0,68	811,6	4,32	20,31
pc= 55/131	-30	-22	916,3	3129	788,6	0,92	3,15	0,79	992,6	4,86	29,01
return gas temp	-25	-13	1257,8	4295	1082,4	1,08	3,68	0,93	1168,3	5,39	40,02
RGT= 32/90	-20	-4	1670,8	5706	1437,9	1,24	4,23	1,07	1347,9	5,92	53,48
liquid temp	-15	5	2158,1	7370	1857,3	1,40	4,78	1,21	1540,4	6,50	69,57
Tliq= 55/131	-5	23	3368,7	11505	2899,2	1,68	5,75	1,45	2001,2	7,88	110,57