

Model

Designation	GS34MFX	220-240V/50Hz 1~	Sales code:	107B0701
-------------	----------------	------------------	-------------	-----------------

Compressor design

Oil type	Polyolester	Refrigerant(s)	R134a, R513A
Oil viscosity	32,5cST	Displacement	33,8cm ³ / 2,06cu.in
Oil quantity	902cm ³ / 30,5fl.oz	Compressors on pallet	48
Refr. charge - tech. limit	2000g / 70,5oz		
Free gas volume comp.	3350cm ³ / 113,3fl.oz		
Weight	20kg / 44,1lbs		
Motor protection	1# internal		
Winding resistance main	2,9Ω (at 25°C)		
Winding resistance aux	5Ω (at 25°C)		
Max. winding temp.	135°C / 275°F		
Max. discharge temp.	130°C / 266°F		



General - Configurations with GS34MFX

	Conf. 1	Conf. 2
Motorconfiguration	CSCR	CSCR
Power supply (nominal)	220-240V/50Hz	220-240V/50Hz
Number of phases	1	1
Voltage range	198-254V	198-254V
Approvals	VDE	VDE
Starting torque	HST	HST
Note	Cover, clamp, gasket: pre-assembled to compressor	

Applications with GS34MFX

	Conf. 1	Conf. 2
Refrigerant	R134a	R513A
Application	MBP	MBP
System cooling	fan 3m/s	fan 3m/s
Hot gas defrost	OK	OK
Long interval pull down	OK	OK

Electrical data - Configurations with GS34MFX

	Conf. 1	Conf. 2
Starting device type	relay	relay
Run capacitor	20μF	20μF
Start capacitor	100μF	100μF
LRA (locked rotor amps / 4s)	26A	26A
RLA (rated load amps / 1s)	4,8A	4,8A
Cut in current	26A	26A
IP class	21	21

Model

Designation

GS34MFX

220-240V/50Hz 1~

Sales code:

107B0701

Compressor dimensions

Housing	A Height	259mm / 10,2in
	B Height	247mm / 9,72in
	C Length shell	224mm / 8,82in
	D Length w. cover	232mm / 9,13in
	E Width	173mm / 6,81in

Connectors	Suction		Discharge		Process	
	X		Y		Z	
Diameter [mm]	øi 12,75-13,05		øi 8,15-8,25		øi 6,4-6,6	
(i:inside, o:outside) [in]	øi 0,5-0,51		øi 0,32-0,32		øi 0,25-0,26	
Material	copper		copper		copper	
Horizontal angle ±2°	0°		0°		0°	
Vertical angle ±2°	90°		71°		90°	
Position l/h/w [mm]	-95/234/-84		-105/84/-84		95/234/84	
	[in]		-3,7/9,2/-3,3		-4,1/3,3/-3,3	
Straight tube l.	[mm]		18		15	
	[in]		0,7		0,6	

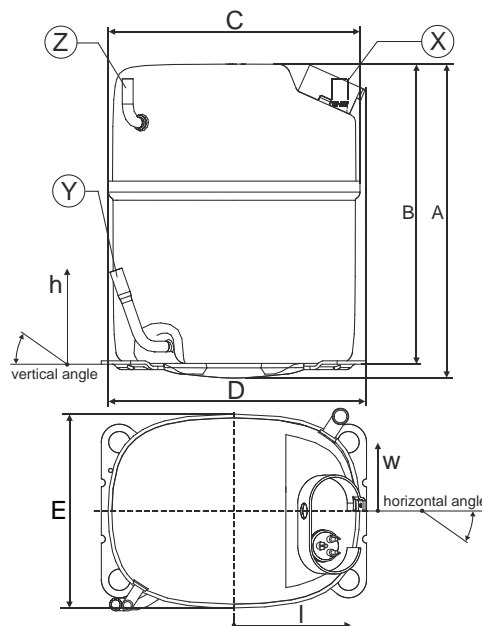

Compressor fixation

Bolt joint

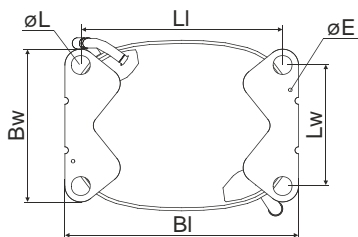

Baseplate	[mm]	[inch]
BI	235	9.25
Bw	154	6.06
øE	ø 3.6	ø 0.14

Large holes	[mm]	[inch]
LI	203	7.99
Lw	122	4.80
øL	ø 19	ø 0.75

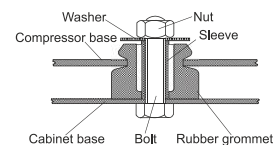

Mounting accessories

Bolt joint | M8 | ø19mm

one comp.

107B9150

Model

Designation	GS34MFX	220-240V/50Hz	Conf. 1	Sales code:	107B0701
-------------	----------------	----------------------	----------------	-------------	-----------------

Configuration

Motorconfiguration	CSCR
Power supply (nominal)	220-240V/50Hz 1~
Refrigerant	R134a
Application	MBP
Voltage range	198-254V
Starting torque	HST
Approvals	VDE

Electrical accessories / wiring diagram

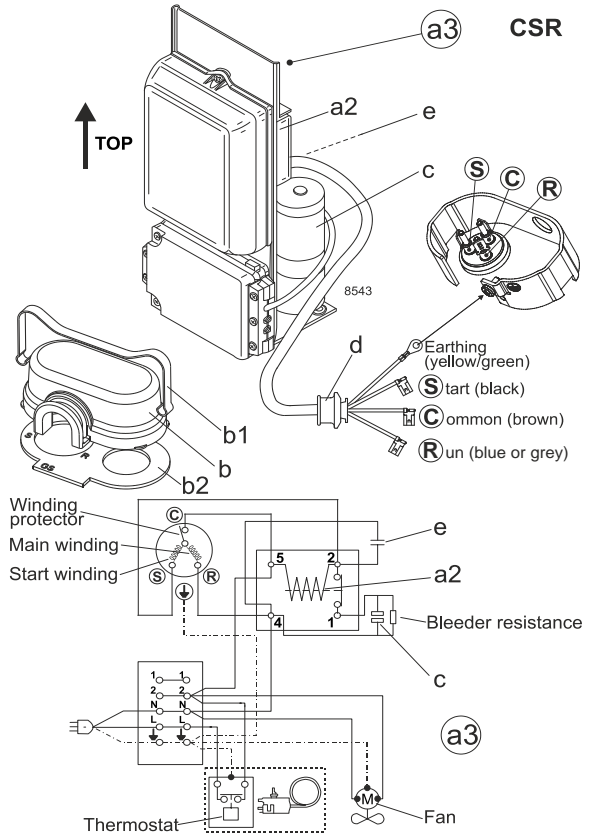

Ambient temperatures / system cooling

Ambient temperature min.:	10°C / 50°F
Ambient temperature max.:	43°C / 110°F

System cooling (n/a: outside limits)			
T ambient	LBP	MBP	HBP
32°C / 90°F	n/a	fan 3m/s	n/a
38°C / 100°F	n/a	fan 3m/s	n/a
43°C / 110°F	n/a	fan 3m/s	n/a

Operation pressure range

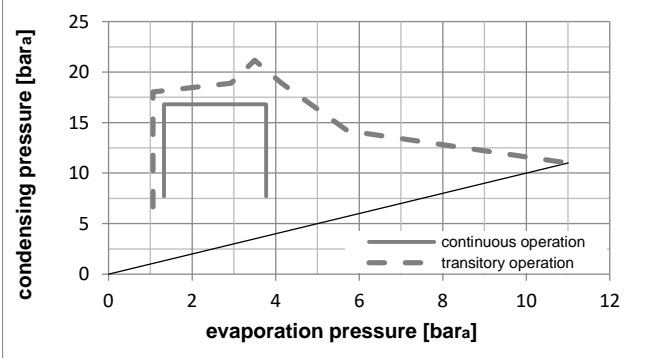
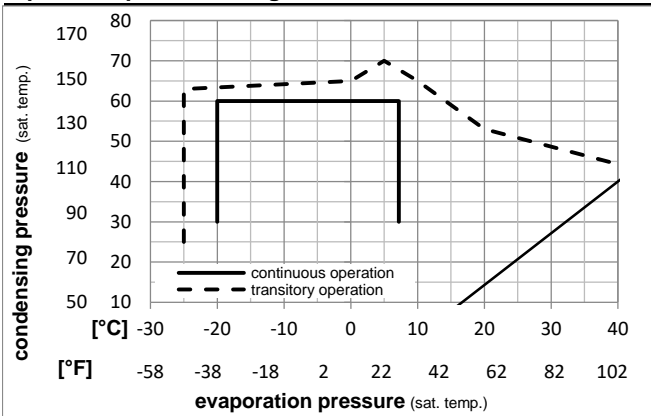

Components (cover, clamp, gasket: pre assembled)

a3	GS starter kit (600mm)	117-7056
b	cover	107B9101
b2	gasket	107B9100
b1	clamp	107B9104

Model

Designation **GS34MFX 220-240V/50Hz** Conf. 1 Sales code: **107B0701**

Optimization + standard conditions

220V/50Hz, CSCR, fan 3m/s, VDE

	Evaporating pressure (saturation temperature)				Condensing pressure (saturation temperature)						Power consumption			ASHRAE MBP				
	pe	pc	RGT	Tliq	Cooling capacity	COP	EER	P1	I	m	Ref. mass flow							
	[°C]	[°F]	[°C]	[°F]	[W]	[Btu/h]	[kcal/h]	[W/W]	[Btu/Wh]	[kcal/Wh]	[W]	[A]	[kg/h]					
	-6,66	20	54,4	130	35	95	46,1	115	1891,2	6459	1627,6	1,80	6,13	1,55	1052,9	5,12	41,26	ASHRAE MBP
	-10	14	55	131	32	89,6	55	131	1456,6	4975	1253,6	1,49	5,08	1,28	979,5	4,79	35,22	cecomaf MBP
	-10	14	45	113	20	68	45	113	1648,3	5629	1418,6	1,81	6,19	1,56	908,8	4,59	38,58	EN12900 MBP
	-6,66	20	48,9	120	18,3	65	48,9	120	1796,4	6135	1546,0	1,79	6,11	1,54	1004,8	5,00	44,37	ARI540 MBP
	-10	14	45	113	32	89,6	45	113	1711,7	5846	1473,1	1,88	6,43	1,62	908,8	4,59	37,46	opt
	-25	-13	45	113	32	89,6	45	113	773,1	2640	665,4	1,23	4,20	1,06	628,1	3,43	16,75	opt

Performance tables

220V/50Hz, CSCR, fan 3m/s, VDE

	pe	Cooling capacity			COP	EER	P1	I	m		
	[°C]	[°F]	[W]	[Btu/h]	[kcal/h]	[W/W]	[Btu/Wh]	[kcal/Wh]	[W]	[A]	[kg/h]
[°C / °F]	-20	-4	1034,7	3534	890,5	1,43	4,89	1,23	722,4	3,78	22,48
cond. pressure	-15	5	1344,6	4592	1157,2	1,65	5,64	1,42	814,8	4,16	29,31
pc= 45/113	-10	14	1711,7	5846	1473,1	1,88	6,43	1,62	908,8	4,59	37,46
return gas temp.	-6,7	20	1989,6	6795	1712,3	2,04	6,98	1,76	973,3	4,90	43,68
RGT= 32/90	-5	23	2145,0	7326	1846,0	2,13	7,27	1,83	1007,7	5,06	47,17
liquid temp	0	32	2653,8	9063	2283,9	2,38	8,13	2,05	1115,1	5,58	58,69
Tliq= 45/113	7,2	45	3538,5	12085	3045,3	2,74	9,36	2,36	1291,1	6,39	79,04
[°C / °F]	-20	-4	851,3	2907	732,6	1,15	3,92	0,99	742,0	3,86	20,42
cond. pressure	-15	5	1129,4	3857	971,9	1,31	4,47	1,13	862,1	4,30	27,19
pc= 55/131	-10	14	1456,6	4975	1253,6	1,49	5,08	1,28	979,5	4,79	35,22
return gas temp	-6,7	20	1704,0	5819	1466,5	1,61	5,51	1,39	1057,1	5,13	41,34
RGT= 32/90	-5	23	1842,2	6291	1585,4	1,68	5,73	1,44	1097,5	5,31	44,78
liquid temp	0	32	2295,3	7839	1975,4	1,88	6,43	1,62	1219,5	5,88	56,14
Tliq= 55/131	7,2	45	3086,1	10540	2656,0	2,19	7,48	1,88	1409,2	6,77	76,33

Model

Designation	GS34MFX	220-240V/50Hz	Conf. 2	Sales code:	107B0701
-------------	----------------	----------------------	----------------	-------------	-----------------

Configuration

Motorconfiguration	CSCR
Power supply (nominal)	220-240V/50Hz 1~
Refrigerant	R513A
Application	MBP
Voltage range	198-254V
Starting torque	HST
Approvals	VDE

Electrical accessories / wiring diagram

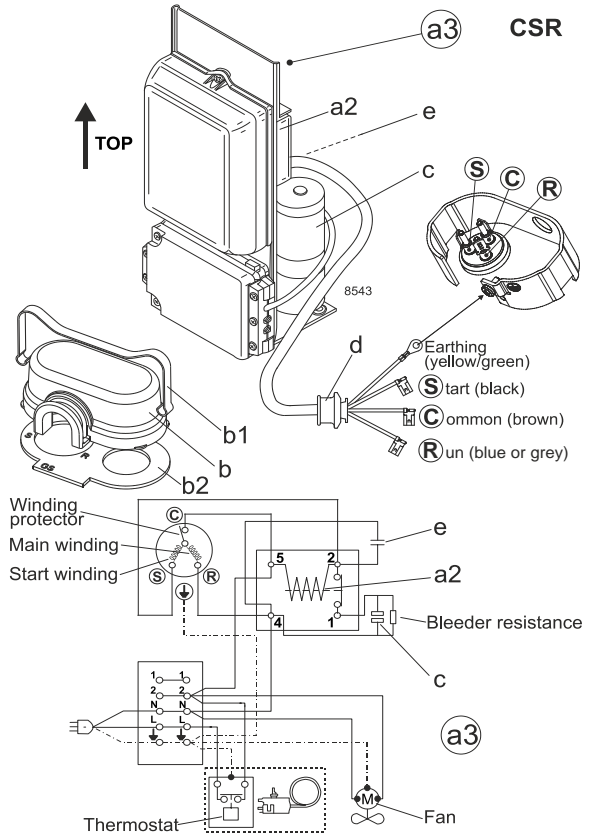

Ambient temperatures / system cooling

Ambient temperature min.:	10°C / 50°F
Ambient temperature max.:	43°C / 110°F

System cooling (n/a: outside limits)			
T ambient	LBP	MBP	HBP
32°C / 90°F	n/a	fan 3m/s	n/a
38°C / 100°F	n/a	fan 3m/s	n/a
43°C / 110°F	n/a	fan 3m/s	n/a

Operation pressure range

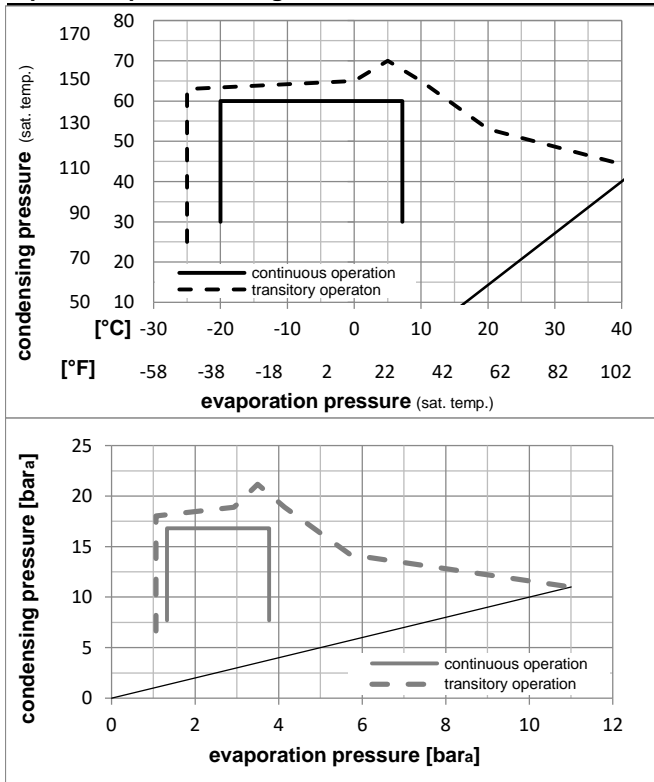

Components (cover, clamp, gasket: pre assembled)

a3	GS starter kit (600mm)	117-7056
b	cover	107B9101
b2	gasket	107B9100
b1	clamp	107B9104

Model

Designation **GS34MFX 220-240V/50Hz** Conf. 2 Sales code: **107B0701**

Optimization + standard conditions

220V/50Hz, CSCR, fan 3m/s, VDE

Evaporating pressure (saturation temperature)														
Condensing pressure (saturation temperature)														
Return gas temp.														
Liquid temp.														
Cooling capacity														
COP														
EER														
Power consumption														
Current consumption														
Ref. mass flow														
	pe	pc	RGT	Tliq	[W]	[Btu/h]	[kcal/h]	[W/W]	[Btu/Wh]	[kcal/Wh]	P1	I	m	
[°C]	[°C]	[°C]	[°C]	[°C]							[W]	[A]	[kg/h]	
[°F]	-6,66	54,4	35	46,1	2000,7	6833	1721,8	1,77	6,04	1,52	1131,6	5,60	49,00	ASHRAE MBP
[°F]	20	130	95	115										
[°C]	-10	55	32	55	1524,9	5208	1312,3	1,44	4,93	1,24	1057,0	5,28	42,17	cecomaf MBP
[°F]	14	131	89,6	131										
[°C]	-10	45	20	45	1734,4	5923	1492,6	1,78	6,07	1,53	976,2	4,93	45,97	EN12900 MBP
[°F]	14	113	68	113										
[°C]	-6,66	48,9	18,3	48,9	1866,0	6373	1605,9	1,73	5,92	1,49	1077,0	5,36	52,58	ARI540 MBP
[°F]	20	120	65	120										
[°C]	-10	45	32	45	1815,3	6199	1562,2	1,86	6,35	1,60	976,2	4,93	44,63	opt
[°F]	14	113	89,6	113										
[°C]	-25	45	32	45	850,9	2906	732,3	1,23	4,21	1,06	690,4	3,70	20,74	opt
[°F]	-13	113	89,6	113										

Performance tables

220V/50Hz, CSCR, fan 3m/s, VDE

	pe	Cooling capacity			COP	EER	P1	I	m		
	[°C]	[°F]	[W]	[Btu/h]	[kcal/h]	[W/W]	[Btu/Wh]	[kcal/Wh]	[W]	[A]	[kg/h]
[°C / °F]	-20	-4	1121,8	3831	965,4	1,42	4,87	1,23	787,2	4,12	27,41
cond. pressure	-15	5	1440,7	4920	1239,8	1,63	5,58	1,41	881,2	4,52	35,30
pc= 45/113	-10	14	1815,3	6199	1562,2	1,86	6,35	1,60	976,2	4,93	44,63
return gas temp.	-6,7	20	2096,8	7161	1804,5	2,01	6,87	1,73	1041,6	5,21	51,69
RGT= 32/90	-5	23	2253,4	7696	1939,3	2,09	7,15	1,80	1076,5	5,36	55,63
liquid temp	0	32	2763,0	9436	2377,8	2,33	7,96	2,00	1186,2	5,83	68,53
Tliq= 45/113	7,2	45	3638,7	12427	3131,5	2,66	9,08	2,29	1368,6	6,61	91,01
[°C / °F]	-20	-4	914,7	3124	787,2	1,12	3,84	0,97	813,7	4,23	25,11
cond. pressure	-15	5	1196,4	4086	1029,7	1,28	4,36	1,10	937,0	4,76	32,96
pc= 55/131	-10	14	1524,9	5208	1312,3	1,44	4,93	1,24	1057,0	5,28	42,17
return gas temp	-6,7	20	1771,0	6048	1524,2	1,56	5,32	1,34	1136,4	5,62	49,11
RGT= 32/90	-5	23	1907,8	6516	1641,9	1,62	5,53	1,39	1177,8	5,79	52,99
liquid temp	0	32	2353,4	8037	2025,3	1,81	6,17	1,55	1303,4	6,33	65,72
Tliq= 55/131	7,2	45	3121,4	10660	2686,3	2,08	7,10	1,79	1500,9	7,18	87,99