

## Model

Designation	<b>NL6.1MLX</b>	220-240V/50Hz 1~ 208-230V/60Hz 1~	Sales code:	<b>105F3615</b>
-------------	-----------------	-----------------------------------	-------------	-----------------

## Compressor design

Oil type	Polyolester	Refrigerant(s)	<b>R404A, R507, R452A</b>
Oil viscosity	32cST	Displacement	6,13cm <sup>3</sup> / 0,37cu.in
Oil quantity	294cm <sup>3</sup> / 10fl.oz	Compressors on pallet	80
Refr. charge - tech. limit	400g / 14,1oz		
Free gas volume comp.	2310cm <sup>3</sup> / 78,1fl.oz		
Weight	10,5kg / 23,1lbs		
Motor protection	1# internal		
Winding resistance main	6,1Ω (at 25°C)		
Winding resistance aux	17,5Ω (at 25°C)		
Max. winding temp.	125°C / 257°F		
Max. discharge temp.	130°C / 266°F		



## General - Configurations with NL6.1MLX

	<b>Conf. 1</b>	<b>Conf. 2</b>	<b>Conf. 3</b>	<b>Conf. 4</b>
Motorconfiguration	CSIR	CSIR	CSIR	CSIR
Power supply (nominal)	220-240V/50Hz	208-230V/60Hz	208-230V/60Hz	220-240V/50Hz
Number of phases	1	1	1	1
Voltage range	187-254V	187-254V	187-254V	187-254V
Approvals	VDE, UL	VDE, UL	VDE, UL	VDE, UL
Starting torque	HST	HST	HST	HST
Note	- / -			

## Applications with NL6.1MLX

	<b>Conf. 1</b>	<b>Conf. 2</b>	<b>Conf. 3</b>	<b>Conf. 4</b>
Refrigerant	R404A	R404A	R452A	R452A
Application	MBP	MBP	MBP	MBP
System cooling	fan 3m/s	fan 3m/s	fan 3m/s	fan 3m/s
Hot gas defrost	- / -	- / -	- / -	- / -
Long interval pull down	OK	OK	OK	OK

## Electrical data - Configurations with NL6.1MLX

	<b>Conf. 1</b>	<b>Conf. 2</b>	<b>Conf. 3</b>	<b>Conf. 4</b>
Starting device type	relay	relay	relay	relay
Run capacitor	- / -	- / -	- / -	- / -
Start capacitor	80μF	80μF	80μF	80μF
LRA (locked rotor amps / 4s)	16,6A	16,1A	16,1A	16,6A
RLA (rated load amps / 1s)	2,8A	2,4A	2,4A	2,8A
Cut in current	17A	15,5A	15,5A	17A
IP class	21	21	21	21

## Model

Designation **NL6.1MLX** 220-240V/50Hz 1~ 208-230V/60Hz 1~ Sales code: **105F3615**

## Compressor dimensions

<b>Housing</b>	A Height	203mm / 7,99in
	B Height	197mm / 7,76in
	C Length shell	205mm / 8,07in
	D Length w. cover	254mm / 10in
	E Width	166mm / 6,54in

Connectors	Suction	Discharge	Process
	X	Y	Z
Diameter [mm]	øi 8,11-8,29	øi 6,41-6,59	øi 6,41-6,59
(i:inside, o:outside) [in]	øi 0,32-0,33	øi 0,25-0,26	øi 0,25-0,26
Material	copper	copper	copper
Horizontal angle ±2°	0°	0°	0°
Vertical angle ±2°	15°	35°	155°
Position l/h/w [mm]	126/76/78	133/103/54	-107/94/72
	[in] 4,9/3/3,1	[in] 5,2/4/2,1	[in] -4,2/3,7/2,8
Straight tube l.	[mm] 12	12	12
	[in] 0,5	0,5	0,5

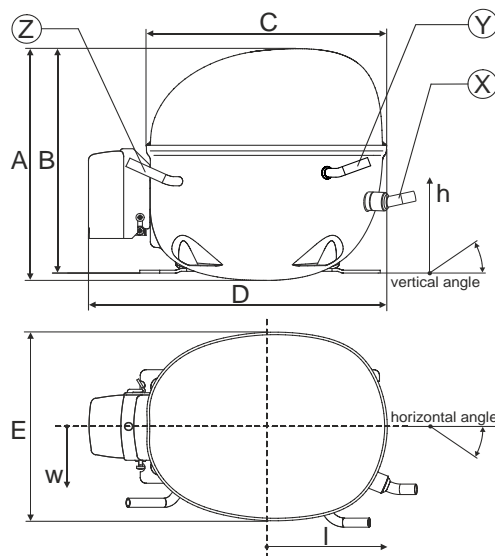

## Compressor fixation

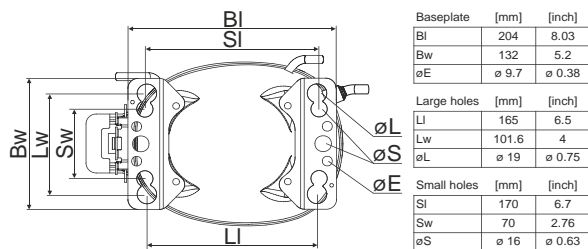

Baseplate	[mm]	[inch]
BI	204	8.03
BW	132	5.2
øE	ø 9.7	ø 0.38
Large holes	[mm]	[inch]
LI	165	6.5
LW	101.6	4
øL	ø 19	ø 0.75
Small holes	[mm]	[inch]
SI	170	6.7
SW	70	2.76
øS	ø 16	ø 0.63

### Bolt joint

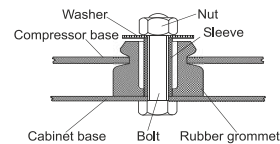

### Snap-on

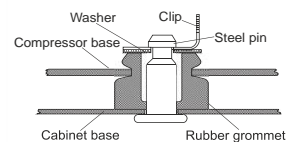

Mounting accessories	one comp.	multi pack
Bolt joint   M6   ø16mm	118-1917	118-1918
Bolt joint   ø1/4"   ø16mm	118-1946	
Bolt joint   ø1/4"   ø19mm	118-1949	
Snap-on   ø7,3   ø16mm	118-1947	118-1919

## Application notes

LRA value on compressor label and datasheet may differ due to different test conditions for UL approval.

## Model

Designation	NL6.1MLX	220-240V/50Hz	Conf. 1	Sales code:	105F3615
-------------	----------	---------------	---------	-------------	----------

## Configuration

Motorconfiguration	CSIR
Power supply (nominal)	220-240V/50Hz 1~
Refrigerant	R404A
Application	MBP
Voltage range	187-254V
Starting torque	HST
Approvals	VDE UL

## Electrical accessories / wiring diagram

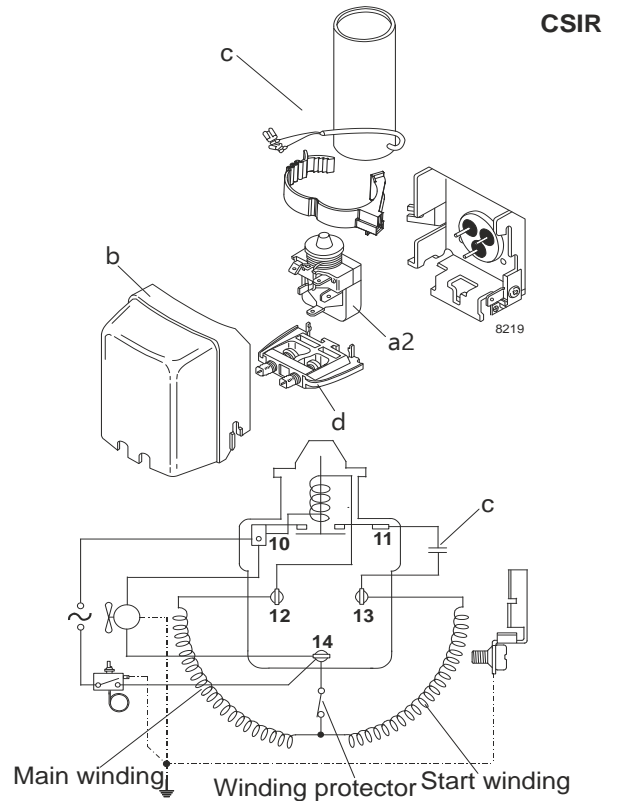

## Ambient temperatures / system cooling

Ambient temperature min.:	10°C / 50°F
Ambient temperature max.:	43°C / 110°F

System cooling (n/a: outside limits)			
T ambient	LBP	MBP	HBP
32°C / 90°F	n/a	fan 3m/s	n/a
38°C / 100°F	n/a	fan 3m/s	n/a
43°C / 110°F	n/a	fan 3m/s	n/a

## Operation pressure range

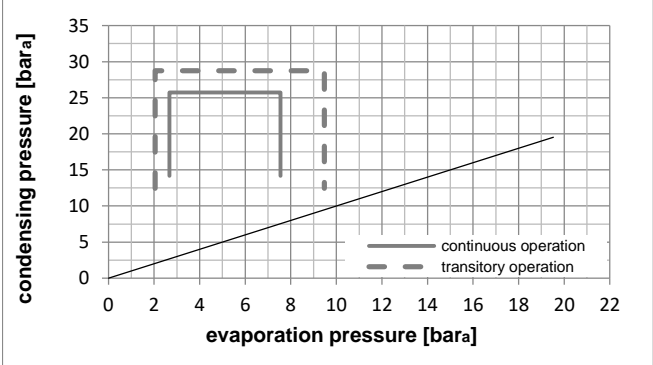
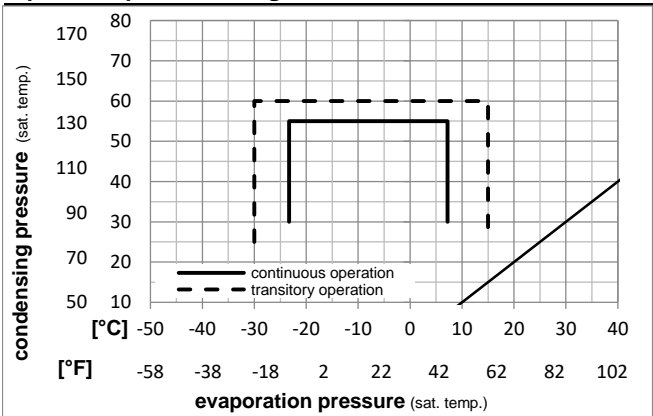

### Components

a2	relay	117U6022
c	start capacitor (80µF)	117U5015
b	plastic cover	103N2011
d	cord relief	103N1010

## Model

Designation **NL6.1MLX 220-240V/50Hz** Conf. 1 Sales code: **105F3615**

## Optimization + standard conditions

R404A, 220V/50Hz, CSIR, fan 3m/s, VDE, UL

Evaporating pressure (saturation temperature)					Condensing pressure (saturation temperature)					Power consumption				ASHRAE MBP
Return gas temp.					Liquid temp.					Current consumption			Ref. mass flow ṁ	
Cooling capacity					COP		EER		P1	I	ṁ			
pe	pc	RGT	Tliq	[W]	[Btu/h]	[kcal/h]	[W/W]	[Btu/Wh]	[kcal/Wh]	[W]		[A]		
[°C]	-6,66	54,4	35	46,1	569,4	1945	490,1	1,61	5,51	1,39	352,8	2,43	15,67	ASHRAE MBP
[°F]	20	130	95	115										
[°C]	-10	55	32	55	422,4	1442	363,5	1,26	4,30	1,08	335,8	2,38	13,52	cecomaf MBP
[°F]	14	131	89,6	131										
[°C]	-10	45	20	45	499,3	1705	429,7	1,60	5,47	1,38	311,9	2,29	15,04	EN12900 MBP
[°F]	14	113	68	113										
[°C]	-6,66	48,9	18,3	48,9	520,3	1777	447,8	1,54	5,27	1,33	337,3	2,37	17,00	ARI540 MBP
[°F]	20	120	65	120										
[°C]	-10	45	32	45	529,9	1810	456,0	1,70	5,80	1,46	311,9	2,29	14,59	opt
[°F]	14	113	89,6	113										
[°C]	-25	45	32	45	256,1	875	220,4	1,09	3,73	0,94	234,1	2,10	6,91	opt
[°F]	-13	113	89,6	113										

## Performance tables

R404A, 220V/50Hz, CSIR, fan 3m/s, VDE, UL

	pe	Cooling capacity			COP		EER		P1	I	m
	[°C]	[°F]	[W]	[Btu/h]	[kcal/h]	[W/W]	[Btu/Wh]	[kcal/Wh]	[W]	[A]	[kg/h]
[°C / °F]	-23,3	-10	281,4	961	242,2	1,16	3,95	0,99	243,6	2,12	7,61
cond. pressure	-20	-4	334,4	1142	287,8	1,28	4,37	1,10	261,5	2,16	9,07
pc= 45/113	-15	5	425,1	1452	365,9	1,48	5,05	1,27	287,4	2,22	11,61
return gas temp.	-10	14	529,9	1810	456,0	1,70	5,80	1,46	311,9	2,29	14,59
RGT= 32/90	-5	23	650,5	2221	559,8	1,94	6,63	1,67	334,8	2,36	18,08
liquid temp	0	32	788,6	2693	678,7	2,22	7,56	1,91	356,0	2,43	22,17
Tliq= 45/113	7,2	45	1021,9	3490	879,4	2,67	9,11	2,29	383,2	2,54	29,30
[°C / °F]	-23,3	-10	214,5	733	184,6	0,84	2,87	0,72	255,4	2,18	6,72
cond. pressure	-20	-4	259,5	886	223,3	0,94	3,21	0,81	276,1	2,23	8,16
pc= 55/131	-15	5	335,4	1146	288,7	1,09	3,74	0,94	306,6	2,30	10,64
return gas temp	-10	14	422,4	1442	363,5	1,26	4,30	1,08	335,8	2,38	13,52
RGT= 32/90	-5	23	522,0	1783	449,3	1,44	4,90	1,24	363,6	2,47	16,90
liquid temp	0	32	636,2	2173	547,5	1,63	5,57	1,40	389,9	2,55	20,86
Tliq= 55/131	7,2	45	829,4	2833	713,8	1,95	6,67	1,68	424,8	2,69	27,84

### Model

Designation	NL6.1MLX	208-230V/60Hz	Conf. 2	Sales code:	105F3615
-------------	----------	---------------	---------	-------------	----------

### Configuration

Motorconfiguration	CSIR
Power supply (nominal)	208-230V/60Hz 1~
Refrigerant	R404A
Application	MBP
Voltage range	187-254V
Starting torque	HST
Approvals	VDE
	UL

### Electrical accessories / wiring diagram

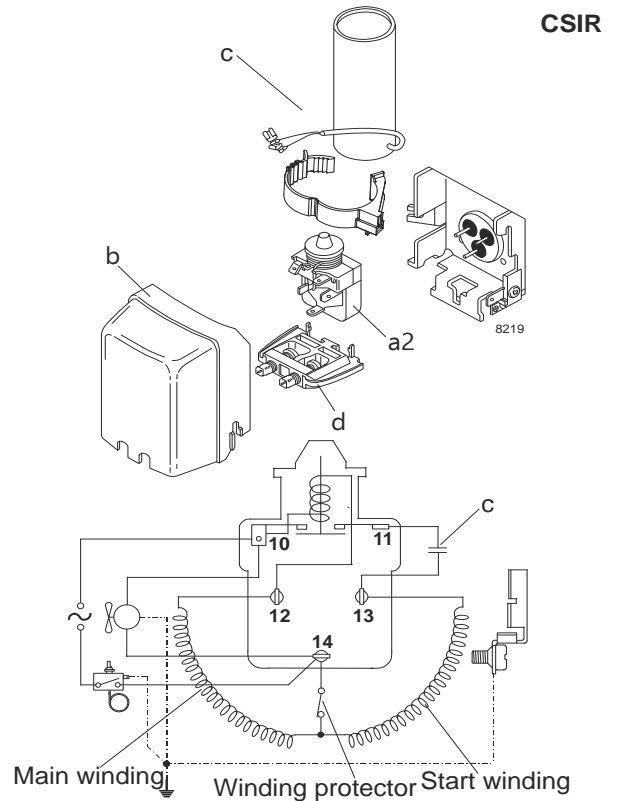

### Ambient temperatures / system cooling

Ambient temperature min.:	10°C / 50°F
Ambient temperature max.:	43°C / 110°F

System cooling (n/a: outside limits)			
T ambient	LBP	MBP	HBP
32°C / 90°F	n/a	fan 3m/s	n/a
38°C / 100°F	n/a	fan 3m/s	n/a
43°C / 110°F	n/a	fan 3m/s	n/a

### Operation pressure range

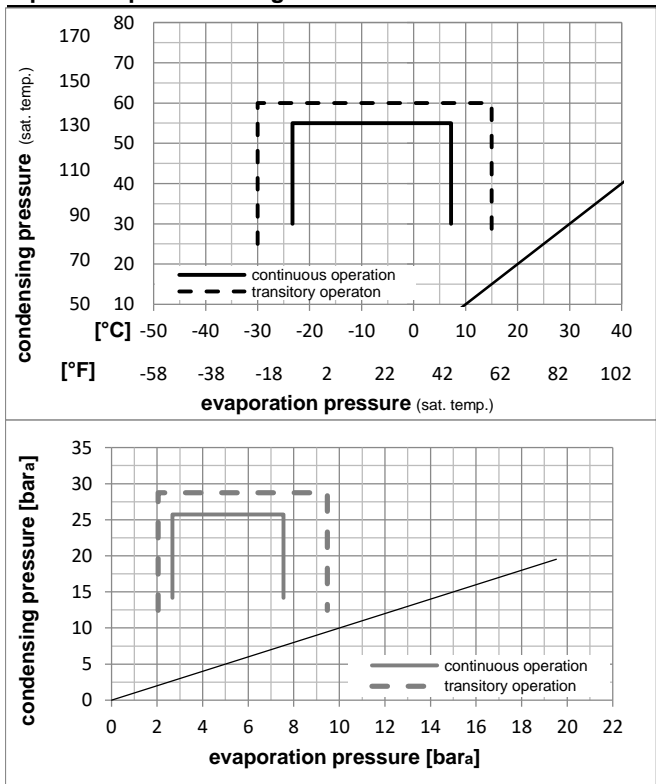

### Components

a2	relay	117U6022
c	start capacitor (80µF)	117U5015
b	plastic cover	103N2011
d	cord relief	103N1010

## Model

Designation **NL6.1MLX 208-230V/60Hz** Conf. 2 Sales code: **105F3615**

## Optimization + standard conditions

R404A, 230V/60Hz, CSIR, fan 3m/s, VDE, UL

		Evaporating pressure (saturation temperature)				Condensing pressure (saturation temperature)						Power consumption			
		Return gas temp.				Liquid temp.						Current consumption		Ref. mass flow	
		Cooling capacity				COP		EER		P1	I	m			
	pe	pc	RGT	Tliq	[W]	[Btu/h]	[kcal/h]	[W/W]	[Btu/Wh]	[kcal/Wh]	[W]	[A]	[kg/h]		
[°C]	-6,7	54,4	35	46,1	676,9	2312	582,6	1,62	5,52	1,39	419,0	2,39	18,63	ASHRAE MBP	
[°F]	20	130	95	115											
[°C]	-10	55	32	55	502,8	1717	432,7	1,28	4,36	1,10	394,1	2,30	16,09	cecmaf MBP	
[°F]	14	131	89,6	131											
[°C]	-10	45	20	45	593,2	2026	510,5	1,61	5,51	1,39	367,6	2,20	17,87	EN12900 MBP	
[°F]	14	113	68	113											
[°C]	-6,7	48,9	18,3	48,9	617,8	2110	531,7	1,54	5,26	1,33	400,8	2,33	20,19	ARI540 MBP	
[°F]	20	120	65	120											
[°C]	-10	45	32	45	629,6	2150	541,8	1,71	5,85	1,47	367,6	2,20	17,34	opt	
[°F]	14	113	89,6	113											
[°C]	-25	45	32	45	309,2	1056	266,1	1,17	4,00	1,01	264,2	1,84	8,34	opt	
[°F]	-13	113	89,6	113											

## Performance tables

R404A, 230V/60Hz, CSIR, fan 3m/s, VDE, UL

	pe	Cooling capacity			COP		EER		P1	I	m
	[°C]	[°F]	[W]	[Btu/h]	[kcal/h]	[W/W]	[Btu/Wh]	[kcal/Wh]	[W]	[A]	[kg/h]
[°C / °F]	-23	-10	338,9	1157	291,7	1,23	4,19	1,05	276,5	1,88	9,16
cond. pressure	-20	-4	400,9	1369	345,0	1,34	4,57	1,15	299,9	1,96	10,88
pc= 45/113	-15	5	507,0	1732	436,4	1,52	5,18	1,31	334,3	2,08	13,85
return gas temp.	-10	14	629,6	2150	541,8	1,71	5,85	1,47	367,6	2,20	17,34
RGT= 32/90	-5	23	770,7	2632	663,2	1,93	6,58	1,66	400,0	2,33	21,42
liquid temp	0	32	932,3	3184	802,3	2,16	7,38	1,86	431,5	2,46	26,21
Tliq= 45/113	7,2	45	1205,2	4116	1037,2	2,53	8,65	2,18	475,6	2,66	34,56
[°C / °F]	-23	-10	257,8	881	221,9	0,91	3,12	0,79	282,3	1,89	8,08
cond. pressure	-20	-4	310,8	1061	267,5	1,00	3,41	0,86	310,8	1,99	9,78
pc= 55/131	-15	5	400,3	1367	344,5	1,13	3,87	0,98	353,1	2,14	12,69
return gas temp	-10	14	502,8	1717	432,7	1,28	4,36	1,10	394,1	2,30	16,09
RGT= 32/90	-5	23	620,3	2118	533,8	1,43	4,88	1,23	434,2	2,45	20,08
liquid temp	0	32	754,8	2578	649,6	1,59	5,45	1,37	473,3	2,62	24,75
Tliq= 55/131	7,2	45	982,7	3356	845,7	1,86	6,35	1,60	528,5	2,85	32,98

## Model

Designation	NL6.1MLX	208-230V/60Hz	Conf. 3	Sales code:	105F3615
-------------	----------	---------------	---------	-------------	----------

## Configuration

Motorconfiguration	CSIR
Power supply (nominal)	208-230V/60Hz 1~
Refrigerant	R452A
Application	MBP
Voltage range	187-254V
Starting torque	HST
Approvals	VDE UL

## Electrical accessories / wiring diagram

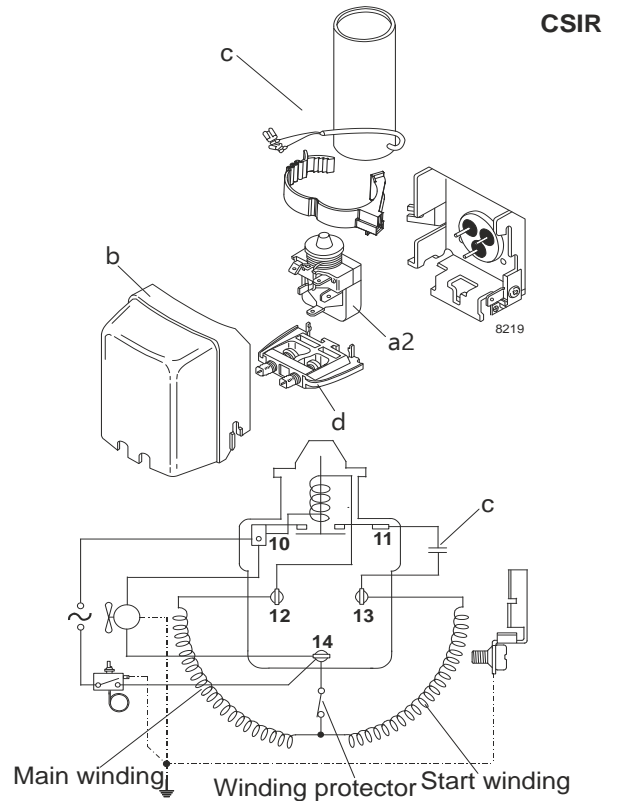

## Ambient temperatures / system cooling

Ambient temperature min.:	10°C / 50°F
Ambient temperature max.:	43°C / 110°F

System cooling (n/a: outside limits)			
T ambient	LBP	MBP	HBP
32°C / 90°F	n/a	fan 3m/s	n/a
38°C / 100°F	n/a	fan 3m/s	n/a
43°C / 110°F	n/a	fan 3m/s	n/a

## Operation pressure range

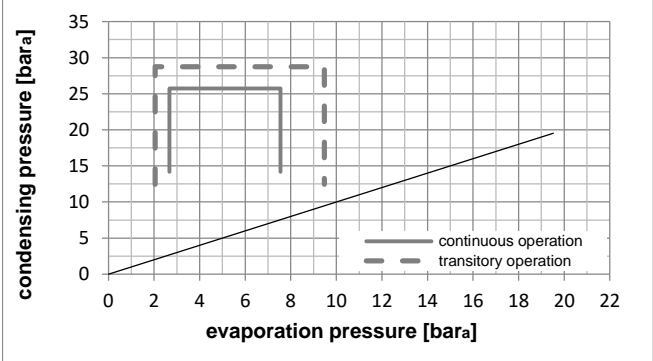
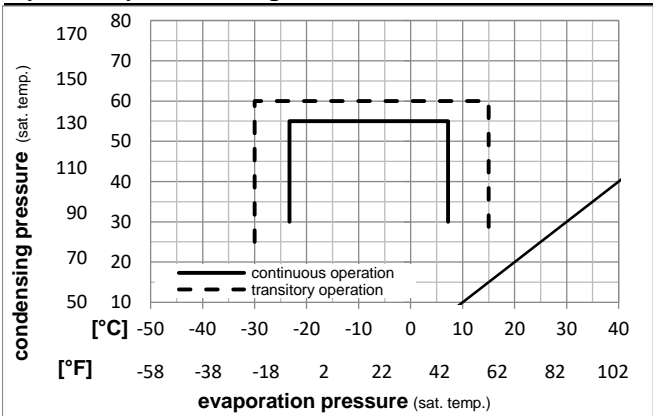

## Components

a2	relay	117U6022
c	start capacitor (80µF)	117U5015
b	plastic cover	103N2011
d	cord relief	103N1010

## Model

Designation **NL6.1MLX 208-230V/60Hz** Conf. 3 Sales code: **105F3615**

## Optimization + standard conditions

R452A, 220V/60Hz, CSIR, fan 3m/s, VDE, UL

Evaporating pressure (saturation temperature)														
Condensing pressure (saturation temperature)														
Return gas temp.														
Liquid temp.														
Cooling capacity														
COP														
EER														
Power consumption														
Current consumption														
Ref. mass flow														
	pe	pc	RGT	Tliq	[W]	[Btu/h]	[kcal/h]	[W/W]	[Btu/Wh]	[kcal/Wh]	P1	I	m	
[°C]	[°C]	[°C]	[°C]	[°C]							[W]	[A]	[kg/h]	
[°F]	20	130	95	115	639,0	2182	550,0	1,60	5,47	1,38	399,3	2,31	17,98	ASHRAE MBP
[°C]	-10	55	32	55	475,5	1624	409,2	1,27	4,34	1,09	374,0	2,22	15,45	cecomaf MBP
[°F]	14	131	89,6	131										
[°C]	-10	45	20	45	559,2	1910	481,3	1,60	5,47	1,38	349,3	2,13	17,18	EN12900 MBP
[°F]	14	113	68	113										
[°C]	-6,66	48,9	18,3	48,9	586,3	2002	504,6	1,53	5,24	1,32	382,1	2,25	19,45	ARI540 MBP
[°F]	20	120	65	120										
[°C]	-10	45	32	45	592,6	2024	510,0	1,70	5,79	1,46	349,3	2,13	16,70	opt
[°F]	14	113	89,6	113										
[°C]	-25	45	32	45	284,4	971	244,8	1,15	3,94	0,99	246,8	1,75	7,87	opt
[°F]	-13	113	89,6	113										

## Performance tables

R452A, 220V/60Hz, CSIR, fan 3m/s, VDE, UL

	pe		Cooling capacity			COP			EER			P1		I		m	
	[°C]	[°F]	[W]	[Btu/h]	[kcal/h]	[W/W]	[Btu/Wh]	[kcal/Wh]	[W]	[A]	[kg/h]						
[°C / °F]	-23,3	-10	312,7	1068	269,1	1,21	4,13	1,04	258,8	1,79	8,67						
cond. pressure	-20	-4	372,1	1271	320,2	1,32	4,51	1,14	281,7	1,88	10,34						
pc= 45/113	-15	5	474,1	1619	408,0	1,50	5,13	1,29	315,9	2,00	13,26						
return gas temp.	-10	14	592,6	2024	510,0	1,70	5,79	1,46	349,3	2,13	16,70						
RGT= 32/90	-5	23	729,6	2492	627,9	1,91	6,52	1,64	382,1	2,25	20,73						
liquid temp	0	32	887,4	3031	763,7	2,14	7,31	1,84	414,4	2,37	25,47						
Tliq= 45/113	7,2	45	1155,0	3945	994,0	2,51	8,57	2,16	460,5	2,54	33,74						
[°C / °F]	-23,3	-10	238,2	814	205,0	0,91	3,09	0,78	263,1	1,81	7,59						
cond. pressure	-20	-4	289,1	987	248,8	0,99	3,39	0,85	291,1	1,91	9,25						
pc= 55/131	-15	5	375,7	1283	323,3	1,13	3,85	0,97	332,9	2,07	12,11						
return gas temp	-10	14	475,5	1624	409,2	1,27	4,34	1,09	374,0	2,22	15,45						
RGT= 32/90	-5	23	590,6	2017	508,3	1,42	4,87	1,23	414,5	2,37	19,39						
liquid temp	0	32	723,2	2470	622,4	1,59	5,43	1,37	454,7	2,52	24,01						
Tliq= 55/131	7,2	45	949,0	3241	816,7	1,85	6,33	1,60	512,0	2,73	32,16						



### Model

Designation	NL6.1MLX	220-240V/50Hz	Conf. 4	Sales code:	105F3615
-------------	----------	---------------	---------	-------------	----------

### Configuration

Motorconfiguration	CSIR
Power supply (nominal)	220-240V/50Hz 1~
Refrigerant	R452A
Application	MBP
Voltage range	187-254V
Starting torque	HST
Approvals	VDE UL

### Electrical accessories / wiring diagram

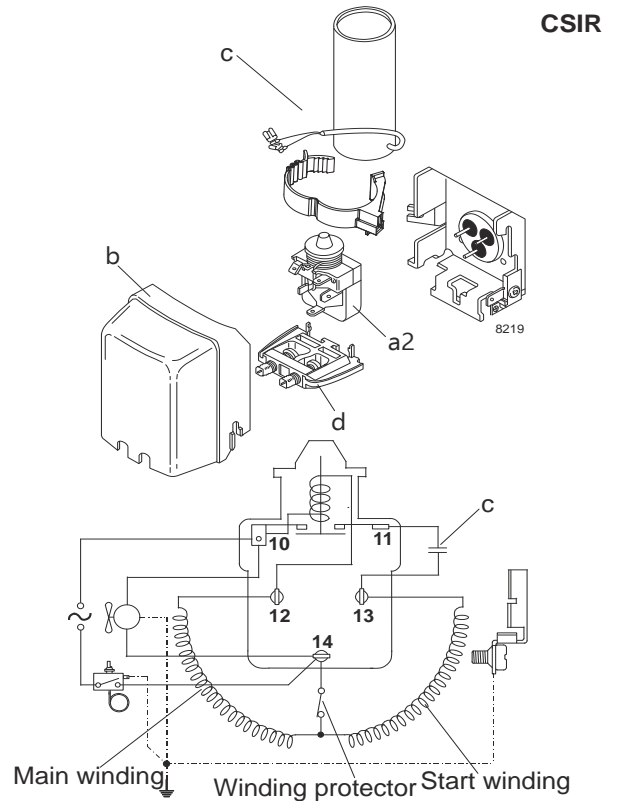

### Ambient temperatures / system cooling

Ambient temperature min.:	10°C / 50°F
Ambient temperature max.:	43°C / 110°F

System cooling (n/a: outside limits)			
T ambient	LBP	MBP	HBP
32°C / 90°F	n/a	fan 3m/s	n/a
38°C / 100°F	n/a	fan 3m/s	n/a
43°C / 110°F	n/a	fan 3m/s	n/a

### Operation pressure range

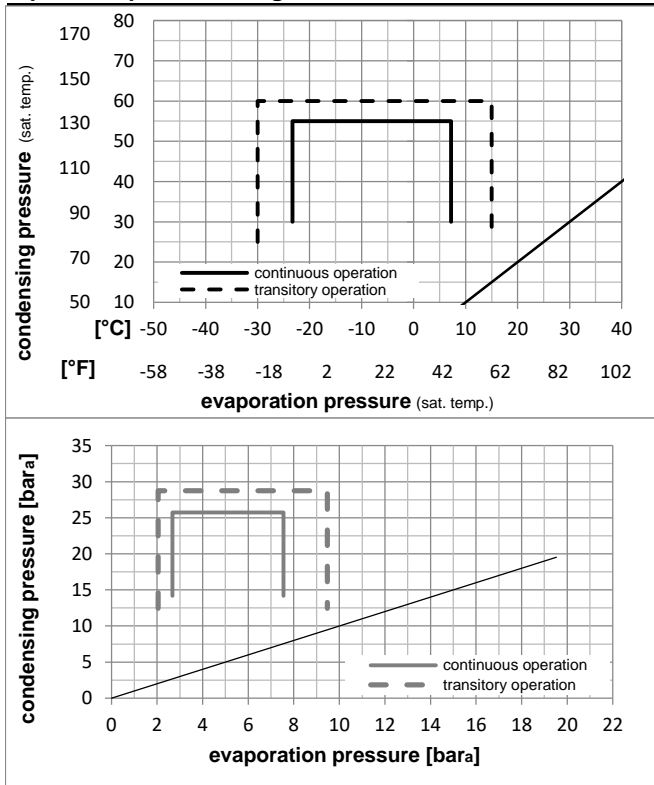

### Components

a2	relay	117U6022
c	start capacitor (80µF)	117U5015
b	plastic cover	103N2011
d	cord relief	103N1010

## Model

Designation **NL6.1MLX 220-240V/50Hz** Conf. 4 Sales code: **105F3615**

## Optimization + standard conditions

R452A, 220V/50Hz, CSIR, fan 3m/s, VDE, UL

Evaporating pressure (saturation temperature)					Condensing pressure (saturation temperature)						Power consumption			ASHRAE MBP
Return gas temp.					Liquid temp.						Current consumption		Ref. mass flow ṁ	
Cooling capacity					COP		EER		P1	I				
pe	pc	RGT	Tliq	[W]	[Btu/h]	[kcal/h]	[W/W]	[Btu/Wh]	[kcal/Wh]	[W]	[A]	[kg/h]		
[°C]	-6,66	54,4	35	46,1	537,9	1837	462,9	1,60	5,48	1,38	335,5	2,39	15,13	ASHRAE MBP
[°F]	20	130	95	115										
[°C]	-10	55	32	55	399,7	1365	344,0	1,26	4,29	1,08	317,9	2,34	12,99	cecomaf MBP
[°F]	14	131	89,6	131										
[°C]	-10	45	20	45	470,9	1608	405,3	1,59	5,44	1,37	295,8	2,28	14,47	EN12900 MBP
[°F]	14	113	68	113										
[°C]	-6,66	48,9	18,3	48,9	494,0	1687	425,1	1,54	5,26	1,32	321,0	2,35	16,39	ARI540 MBP
[°F]	20	120	65	120										
[°C]	-10	45	32	45	499,0	1704	429,5	1,69	5,76	1,45	295,8	2,28	14,06	opt
[°F]	14	113	89,6	113										
[°C]	-25	45	32	45	235,7	805	202,8	1,08	3,69	0,93	218,0	2,05	6,52	opt
[°F]	-13	113	89,6	113										

## Performance tables

R452A, 220V/50Hz, CSIR, fan 3m/s, VDE, UL

	pe	Cooling capacity			COP		EER		P1	I	m
	[°C]	[°F]	[W]	[Btu/h]	[kcal/h]	[W/W]	[Btu/Wh]	[kcal/Wh]	[W]	[A]	[kg/h]
[°C / °F]	-23,3	-10	259,8	887	223,6	1,14	3,90	0,98	227,3	2,08	7,20
cond. pressure	-20	-4	310,5	1061	267,2	1,27	4,33	1,09	245,1	2,13	8,63
pc= 45/113	-15	5	397,7	1358	342,3	1,47	5,01	1,26	271,0	2,20	11,13
return gas temp.	-10	14	499,0	1704	429,5	1,69	5,76	1,45	295,8	2,28	14,06
RGT= 32/90	-5	23	616,2	2104	530,3	1,93	6,59	1,66	319,3	2,34	17,51
liquid temp	0	32	751,0	2565	646,3	2,20	7,51	1,89	341,4	2,41	21,55
Tliq= 45/113	7,2	45	979,8	3346	843,2	2,64	9,03	2,28	370,6	2,49	28,62
[°C / °F]	-23,3	-10	198,3	677	170,7	0,84	2,86	0,72	237,2	2,11	6,32
cond. pressure	-20	-4	241,5	825	207,9	0,94	3,20	0,81	257,8	2,17	7,73
pc= 55/131	-15	5	315,0	1076	271,1	1,09	3,73	0,94	288,3	2,25	10,15
return gas temp	-10	14	399,7	1365	344,0	1,26	4,29	1,08	317,9	2,34	12,99
RGT= 32/90	-5	23	497,4	1699	428,1	1,44	4,90	1,24	346,4	2,42	16,33
liquid temp	0	32	609,9	2083	524,9	1,63	5,57	1,40	373,8	2,50	20,25
Tliq= 55/131	7,2	45	801,4	2737	689,7	1,95	6,66	1,68	411,1	2,61	27,16