

Model

Designation	NLE10CN	220-240V/50Hz 1~	Sales code:	105H6176
-------------	----------------	-------------------------	-------------	-----------------

Compressor design

Oil type	Polyolester	Refrigerant(s)	R290
Oil viscosity	32cSt	Displacement	10,09cm ³ / 0,62cu.in
Oil quantity	270cm ³ / 9,1fl.oz	Compressors on pallet	80
Refr. charge - tech. limit	150g / 5,3oz		
Free gas volume comp.	2360cm ³ / 79,8fl.oz		
Weight	10,9kg / 24lbs		
Motor protection	1# internal		
Winding resistance main	7,79Ω (at 25°C)		
Winding resistance aux	18,39Ω (at 25°C)		
Max. winding temp.	125°C / 257°F		
Max. discharge temp.	120°C / 248°F		



General - Configurations with NLE10CN

Conf. 1	
Motorconfiguration	RSIR
Power supply (nominal)	220-240V/50Hz
Number of phases	1
Voltage range	198-254V
Approvals	VDE
Starting torque	LST
Note	Electrical equipment is included and pre-assembled to compressor.

Applications with NLE10CN

Conf. 1	
Refrigerant	R290
Application	LBP+MBP
System cooling	fan 3m/s
Hot gas defrost	OK
Long interval pull down	OK

Electrical data - Configurations with NLE10CN

Conf. 1	
Starting device type	PTC
Run capacitor	-/-
Start capacitor	-/-
LRA (locked rotor amps / 4s)	10,9A
RLA (rated load amps / 1s)	2,58A
Cut in current	15,8A
IP class	21

Model

Designation

NLE10CN

220-240V/50Hz 1~

Sales code:

105H6176

Compressor dimensions

Housing	A Height	203mm / 7,99in
	B Height	197mm / 7,76in
	C Length shell	205mm / 8,07in
	D Length w. cover	254mm / 10in
	E Width	166mm / 6,54in

Connectors		Suction	Discharge	Process
		X	Y	Z
Diameter	[mm]	øi 8,11-8,29	øi 6,11-6,29	øi 6,11-6,29
(i:inside, o:outside)	[in]	øi 0,32-0,33	øi 0,24-0,25	øi 0,24-0,25
Material		copper	copper	copper
Horizontal angle	±2°	0°	0°	0°
Vertical angle	±2°	15°	21°	155°
Position l/h/w	[mm]	132/69/56	94/99/86	-111/92/72
	[in]	5,2/2,7/2,2	3,7/3,9/3,4	-4,4/3,6/2,8
Straight tube l.	[mm]	12	12	12
	[in]	0,5	0,5	0,5

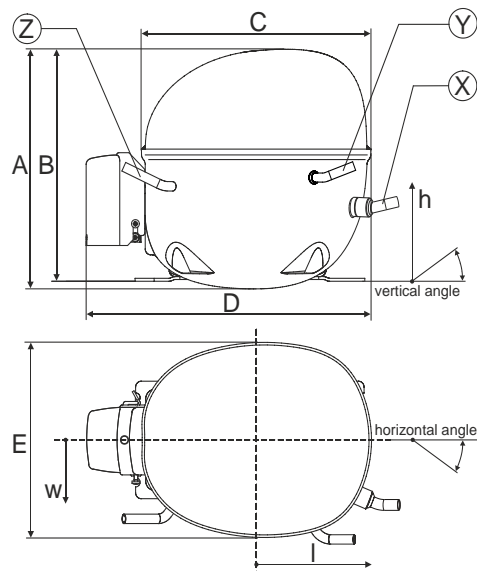

Compressor fixation

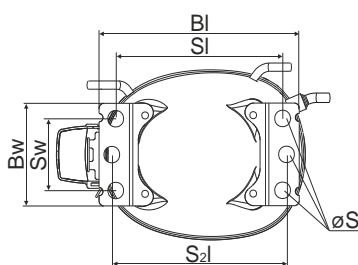

Baseplate	[mm]	[inch]
BI	204	8.03
BW	100	3.94

Small holes	[mm]	[inch]
SI	170	6.7
SW	70	2.76
S2I	178	7
øS	ø 16	ø 0.63

Bolt joint

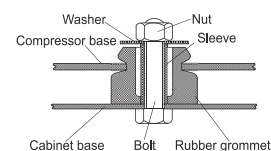

Snap-on

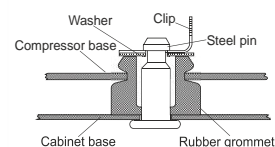

Mounting accessories

	one comp.	multi pack
Bolt joint M6 ø16mm	118-1917	118-1918
Bolt joint ø1/4" ø16mm	118-1946	
Snap-on ø7,3 ø16mm	118-1947	118-1919

Model

Designation	NLE10CN	220-240V/50Hz	Conf. 1	Sales code:	105H6176
-------------	----------------	----------------------	----------------	-------------	-----------------

Configuration

Motorconfiguration	RSIR
Power supply (nominal)	220-240V/50Hz 1~
Refrigerant	R290
Application	LBP+MBP
Voltage range	198-254V
Starting torque	LST
Approvals	VDE

Electrical accessories / wiring diagram

RSIR

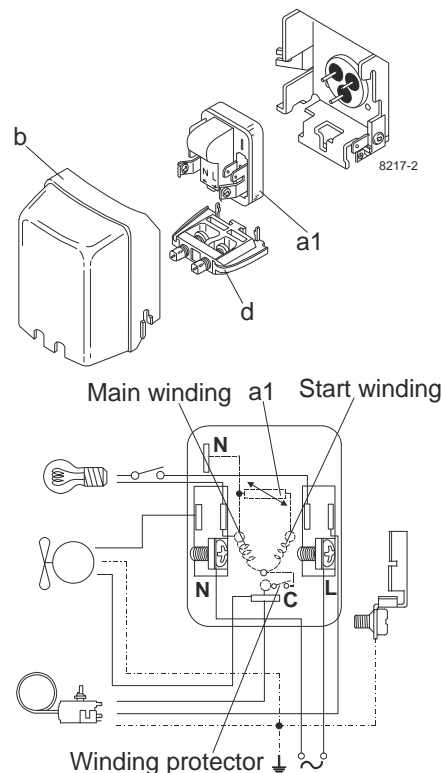

Ambient temperatures / system cooling

Ambient temperature min.:	10°C / 50°F
Ambient temperature max.:	43°C / 110°F

System cooling (n/a: outside limits)			
T ambient	LBP	MBP	HBP
32°C / 90°F	fan 3m/s	fan 3m/s	n/a
38°C / 100°F	fan 3m/s	fan 3m/s	n/a
43°C / 110°F	fan 3m/s	fan 3m/s	n/a

Operation pressure range

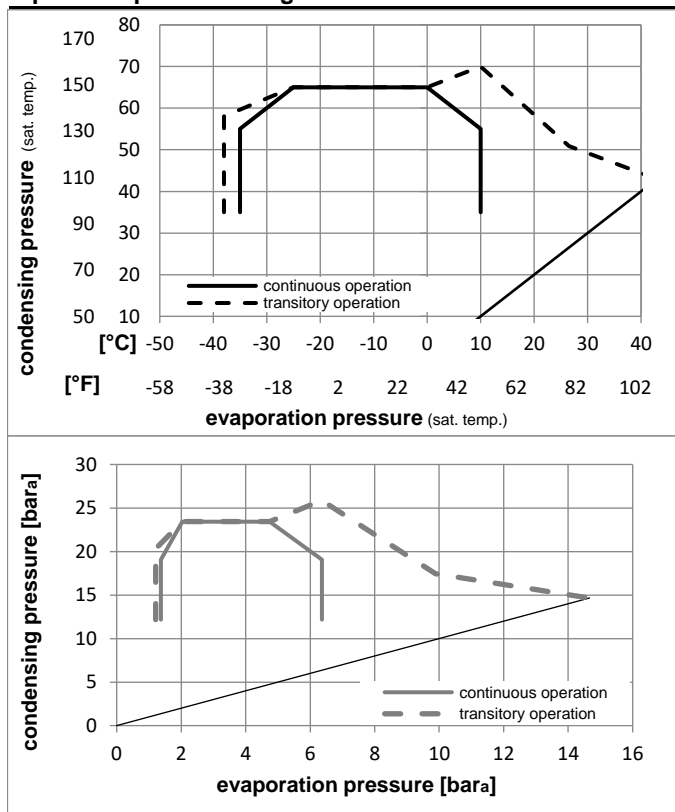

Components (already pre-assembled)

a1	e-PTC starter (220V, 25Ohm, 4.8mm)	103N0050
b	plastic cover	103N2010
d	cord relief	103N1010

Alternative components

b	plastic cover	103N2011
---	---------------	----------

Model

Designation **NLE10CN 220-240V/50Hz** Conf. 1 Sales code: **105H6176**

Optimization + standard conditions

220-240V/50Hz 1~, RSIR, fan 3m/s, VDE

	Evaporating pressure (saturation temperature)				Condensing pressure (saturation temperature)						Power consumption			ASHRAE LBP
	pe	pc	RGT	Tliq	Cooling capacity			COP	EER	P1	I	Ref. mass flow		
	[°C]	[°C]	[°C]	[°C]	[W]	[Btu/h]	[kcal/h]	[W/W]	[Btu/Wh]	[kcal/Wh]	[W]	[A]	[kg/h]	
	-23,3	54,4	32,2	32,2	485,4	1658	417,7	1,47	5,00	1,26	331,3	2,15	4,92	
	[°F]	-10	130	90										
	-25	55	32	55	362,5	1238	312,0	1,14	3,88	0,98	318,8	2,11	4,51	cecomaf LBP
	[°F]	-13	131	89,6										
	-35	40	20	40	285,5	975	245,7	1,23	4,21	1,06	231,7	1,87	3,26	EN12900 LBP
	[°F]	-31	104	68										
	-6,66	54,4	35	46,1	873,2	2982	751,5	1,89	6,44	1,62	462,7	2,62	9,96	ASHRAE MBP
	[°F]	20	130	95										
	-10	55	32	55	693,0	2367	596,4	1,58	5,39	1,36	439,1	2,53	8,77	cecomaf MBP
	[°F]	14	131	89,6										
	-10	45	20	45	781,1	2667	672,2	1,96	6,70	1,69	398,0	2,39	9,59	EN12900 MBP
	[°F]	14	113	68										

Performance tables

220-240V/50Hz 1~, RSIR, fan 3m/s, VDE

	pe	Cooling capacity			COP			EER			P1	I	m
	[°C]	[°F]	[W]	[Btu/h]	[kcal/h]	[W/W]	[Btu/Wh]	[kcal/Wh]	[W]	[A]	[kg/h]		
[°C / °F]	-35	-31	274,0	936	235,8	1,16	3,96	1,00	236,0	1,89	3,07		
cond. pressure	-25	-13	436,9	1492	376,0	1,45	4,94	1,25	301,9	2,06	4,93		
pc= 45/113	-15	5	668,8	2284	575,6	1,82	6,21	1,57	367,6	2,28	7,61		
return gas temp.	-10	14	813,1	2777	699,8	2,04	6,98	1,76	398,0	2,39	9,30		
RGT= 32/90	0	32	1163,7	3974	1001,5	2,59	8,85	2,23	449,2	2,58	13,50		
liquid temp	5	41	1371,8	4685	1180,6	2,93	10,01	2,52	468,2	2,65	16,05		
Tliq= 45/113	10	50	1603,3	5475	1379,8	3,33	11,37	2,87	481,5	2,70	18,95		
[°C / °F]	-35	-31	215,5	736	185,4	0,88	3,01	0,76	244,6	1,91	2,66		
cond. pressure	-25	-13	362,5	1238	312,0	1,14	3,88	0,98	318,8	2,11	4,51		
pc= 55/131	-15	5	566,9	1936	487,9	1,42	4,85	1,22	399,1	2,38	7,13		
return gas temp.	-10	14	693,0	2367	596,4	1,58	5,39	1,36	439,1	2,53	8,77		
RGT= 32/90	0	32	998,3	3409	859,2	1,94	6,63	1,67	514,5	2,82	12,82		
liquid temp	5	41	1179,4	4028	1015,0	2,15	7,35	1,85	547,9	2,96	15,29		
Tliq= 55/131	10	50	1380,9	4716	1188,4	2,39	8,17	2,06	577,2	3,09	18,11		