

## Model

Designation	<b>NLE11CNL</b>	<b>220-240V/50Hz 1~</b>	Sales code:	<b>105H6174</b>
-------------	-----------------	-------------------------	-------------	-----------------

## Compressor design

Oil type	Polyolester	Refrigerant(s)	<b>R290</b>
Oil viscosity	32cSt	Displacement	11,15cm <sup>3</sup> / 0,68cu.in
Oil quantity	300cm <sup>3</sup> / 10,1fl.oz	Compressors on pallet	80
Refr. charge - tech. limit	150g / 5,3oz		
Free gas volume comp.	2360cm <sup>3</sup> / 79,8fl.oz		
Weight	12,1kg / 26,7lbs		
Motor protection	1# internal		
Winding resistance main	7,72Ω (at 25°C)		
Winding resistance aux	17,82Ω (at 25°C)		
Max. winding temp.	125°C / 257°F		
Max. discharge temp.	130°C / 266°F		



## General - Configurations with NLE11CNL

	<b>Conf. 1</b>	<b>Conf. 2</b>
Motorconfiguration	CSIR	RSIR
Power supply (nominal)	220-240V/50Hz	220-240V/50Hz
Number of phases	1	1
Voltage range	198-254V	198-254V
Approvals	VDE, CCC	VDE, CCC
Starting torque	HST	LST
Note	- / -	

## Applications with NLE11CNL

	<b>Conf. 1</b>	<b>Conf. 2</b>
Refrigerant	R290	R290
Application	LBP	LBP
System cooling	fan 3m/s	fan 3m/s
Hot gas defrost	OK	OK
Long interval pull down	OK	OK

## Electrical data - Configurations with NLE11CNL

	<b>Conf. 1</b>	<b>Conf. 2</b>
Starting device type	relay	PTC
Run capacitor	0μF	0μF
Start capacitor	80μF	0μF
LRA (locked rotor amps / 4s)	13,8A	12,6A
RLA (rated load amps / 1s)	2,59A	2,59A
Cut in current	13,8A	17,1A
IP class	21	21

## Model

Designation

**NLE11CNL**

**220-240V/50Hz 1~**

Sales code:

**105H6174**

## Compressor dimensions

Housing	A Height	203mm / 7,99in
	B Height	197mm / 7,76in
	C Length shell	205mm / 8,07in
	D Length w. cover	254mm / 10in
	E Width	166mm / 6,54in

Connectors		Suction	Discharge	Process
		X	Y	Z
Diameter	[mm]	øi 8,11-8,29	øi 6,11-6,29	øi 6,11-6,29
(i:inside, o:outside)	[in]	øi 0,32-0,33	øi 0,24-0,25	øi 0,24-0,25
Material		copper	copper	copper
Horizontal angle	±2°	0°	0°	0
Vertical angle	±2°	15°	21°	155°
Position l/h/w	[mm]	132/69/56	94/99/86	-111/92/72
	[in]	5,2/2,7/2,2	3,7/3,9/3,4	-4,4/3,6/2,8
Straight tube l.	[mm]	12	12	12
	[in]	0,5	0,5	0,5

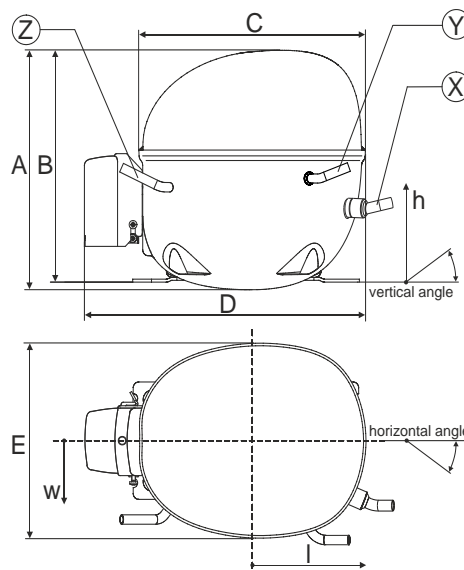

## Compressor fixation

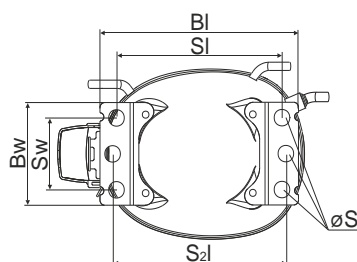

Baseplate	[mm]	[inch]
BI	204	8.03
Bw	100	3.94
Small holes		
SI	170	6.7
Sw	70	2.76
S1	178	7
øS	ø 16	ø 0.63

### Bolt joint

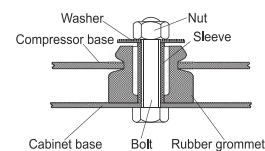

### Snap-on

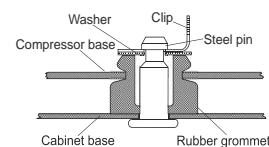

## Mounting accessories

	one comp.	multi pack
Bolt joint   M6   ø16mm	118-1917	118-1918
Bolt joint   ø1/4"   ø16mm	118-1946	
Snap-on   ø7,3   ø16mm	118-1947	118-1919

### Model

Designation	<b>NLE11CNL</b>	<b>220-240V/50Hz</b>	<b>Conf. 1</b>	Sales code:	<b>105H6174</b>
-------------	-----------------	----------------------	----------------	-------------	-----------------

### Configuration

Motorconfiguration	CSIR
Power supply (nominal)	220-240V/50Hz 1~
Refrigerant	R290
Application	LBP
Voltage range	198-254V
Starting torque	HST
Approvals	VDE
	CCC

### Electrical accessories / wiring diagram

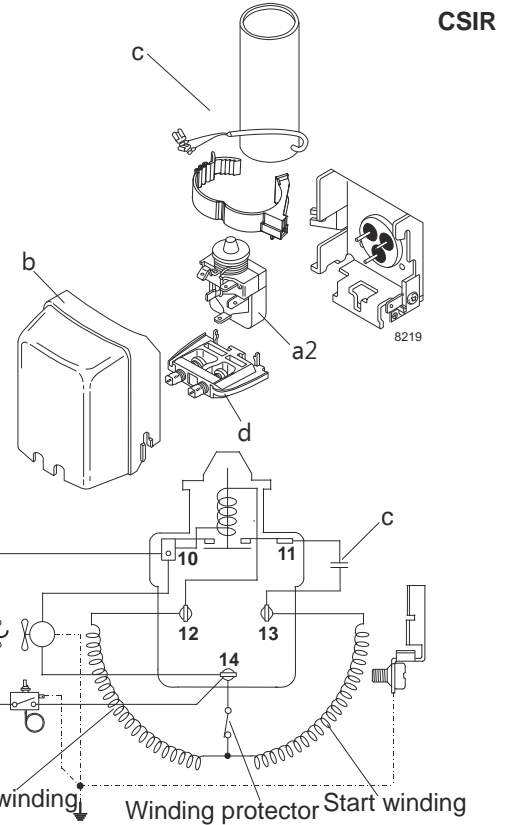

### Ambient temperatures / system cooling

Ambient temperature min.:	10°C / 50°F
Ambient temperature max.:	43°C / 110°F

System cooling			
T ambient	LBP	MBP	HBP
32°C / 90°F	fan 3m/s	n/a	n/a
38°C / 100°F	fan 3m/s	n/a	n/a
43°C / 110°F	fan 3m/s	n/a	n/a

### Operation pressure range

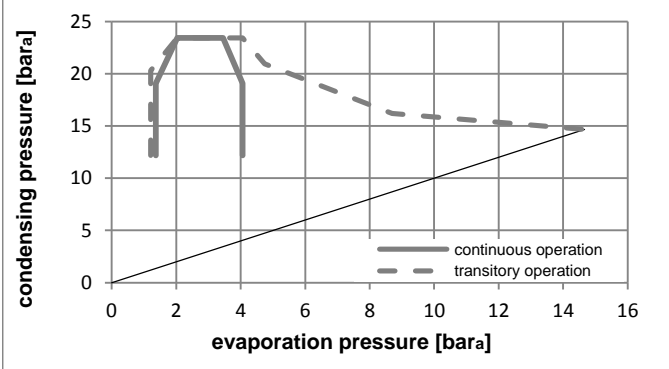
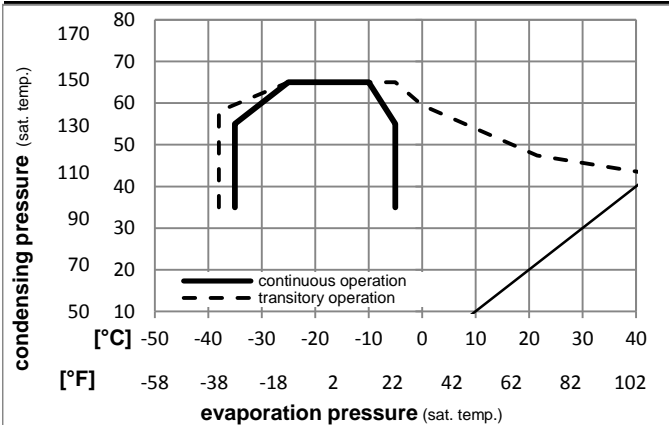

### Components:

a2	relay	117U7003
c	start capacitor (80µF)	117U5015
b	plastic cover	103N2010
d	cord relief	103N1010

### Alternative components:

b	plastic cover	103N2011
---	---------------	----------

### Model

Designation **NLE11CNL 220-240V/50Hz** Conf. 1 Sales code: **105H6174**

### Optimization + standard conditions

220-240V/50Hz 1~, CSIR, fan 3m/s, VDE, CCC

	Evaporating pressure (saturation temperature)				Condensing pressure (saturation temperature)						Power consumption			ASHRAE LBP
	pe	pc	RGT	Tliq	Cooling capacity			COP	EER	P1	I	Ref. mass flow		
	[°C]	[°F]	[°C]	[°F]	[W]	[Btu/h]	[kcal/h]	[W/W]	[Btu/Wh]	[kcal/Wh]	[W]	[A]	[kg/h]	
	-23,3	54,4	32,2	32,2	538,9	1840	463,8	1,52	5,18	1,31	355,3	2,22	5,46	ASHRAE LBP
	-10	130	90	90										
	-25	55	32	55	403,0	1376	346,8	1,18	4,02	1,01	342,6	2,18	5,02	cecomaf LBP
	-13	131	89,6	131										
	-35	40	20	40	304,9	1041	262,4	1,18	4,03	1,02	258,2	1,95	3,48	EN12900 LBP
	-31	104	68	104										
	-23,3	48,9	4,44	48,9	440,2	1503	378,9	1,27	4,34	1,09	346,6	2,19	6,10	ARI540 LBP
	-10	120	40	120										
	-23,3	40,6	32,2	32,2	589,5	2013	507,3	1,77	6,06	1,53	332,4	2,15	5,97	AHAM LBP
	-10	105	90	90										
	-35	45	32	45	291,4	995	250,8	1,11	3,80	0,96	262,0	1,96	3,27	opt
	-31	113	89,6	113										

### Performance tables

220-240V/50Hz 1~, CSIR, fan 3m/s, VDE, CCC

	pe	Cooling capacity			COP	EER	P1	I	m		
	[°C]	[°F]	[W]	[Btu/h]	[kcal/h]	[W/W]	[Btu/Wh]	[kcal/Wh]	[W]	[A]	[kg/h]
[°C / °F]	-35	-31	291,4	995	250,8	1,11	3,80	0,96	262,0	1,96	3,27
cond. pressure	-30	-22	375,5	1282	323,1	1,28	4,36	1,10	294,4	2,04	4,22
pc= 45/113	-25	-13	477,1	1629	410,6	1,45	4,96	1,25	328,6	2,14	5,38
return gas temp.	-23,3	-10	515,7	1761	443,8	1,51	5,17	1,30	340,5	2,18	5,82
RGT= 32/90	-20	-4	596,6	2037	513,4	1,64	5,60	1,41	364,0	2,25	6,76
liquid temp	-15	5	734,3	2508	632,0	1,84	6,27	1,58	400,1	2,38	8,35
Tliq= 45/113	-5	23	1066,2	3641	917,6	2,26	7,71	1,94	472,3	2,65	12,28
[°C / °F]	-35	-31	242,7	829	208,9	0,91	3,10	0,78	267,6	1,97	3,00
cond. pressure	-30	-22	314,8	1075	271,0	1,04	3,54	0,89	303,5	2,06	3,91
pc= 55/131	-25	-13	403,0	1376	346,8	1,18	4,02	1,01	342,6	2,18	5,02
return gas temp	-23,3	-10	436,6	1491	375,8	1,22	4,18	1,05	356,5	2,23	5,44
RGT= 32/90	-20	-4	507,4	1733	436,7	1,32	4,51	1,14	384,3	2,32	6,35
liquid temp	-15	5	628,6	2147	540,9	1,47	5,01	1,26	428,3	2,49	7,90
Tliq= 55/131	-5	23	922,4	3150	793,9	1,77	6,05	1,52	521,0	2,85	11,75

## Model

Designation	<b>NLE11CNL</b>	<b>220-240V/50Hz</b>	<b>Conf. 2</b>	Sales code:	<b>105H6174</b>
-------------	-----------------	----------------------	----------------	-------------	-----------------

## Configuration

Motorconfiguration	RSIR
Power supply (nominal)	220-240V/50Hz 1~
Refrigerant	R290
Application	LBP
Voltage range	198-254V
Starting torque	LST
Approvals	VDE
	CCC

## Electrical accessories / wiring diagram

RSIR

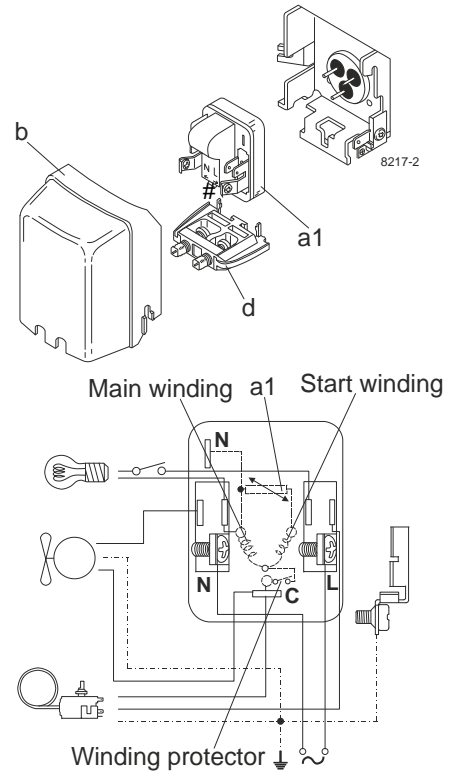

## Ambient temperatures / system cooling

Ambient temperature min.:	10°C / 50°F
Ambient temperature max.:	43°C / 110°F

System cooling			
T ambient	LBP	MBP	HBP
32°C / 90°F	fan 3m/s	n/a	n/a
38°C / 100°F	fan 3m/s	n/a	n/a
43°C / 110°F	fan 3m/s	n/a	n/a

## Operation pressure range

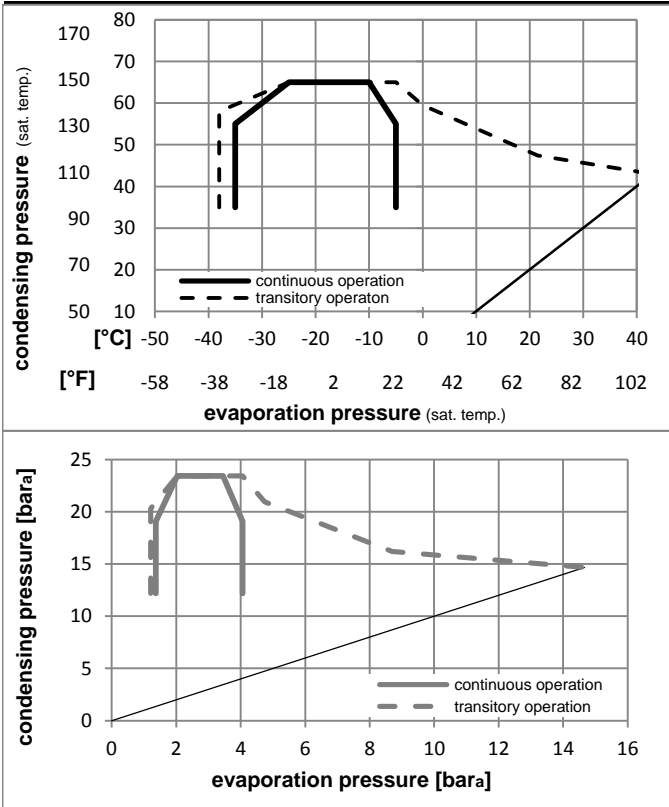

### Components:

a1	e-PTC starter (220V, 250hm, 4.8mm)	103N0050
b	plastic cover	103N2010
d	cord relief	103N1010

### Alternative components:

b	plastic cover	103N2011
---	---------------	----------

### Model

Designation **NLE11CNL 220-240V/50Hz** Conf. 2 Sales code: **105H6174**

### Optimization + standard conditions

220-240V/50Hz 1~, RSIR, fan 3m/s, VDE, CCC

	Evaporating pressure (saturation temperature)				Condensing pressure (saturation temperature)						Power consumption			ASHRAE LBP				
	pe	pc	RGT	Tliq	Cooling capacity			COP	EER	P1	I	Ref. mass flow						
	[°C]	[°F]	[°C]	[°F]	[W]	[Btu/h]	[kcal/h]	[W/W]	[Btu/Wh]	[kcal/Wh]	[W]	[A]	[kg/h]					
	-23,3	-10	54,4	130	32,2	90	32,2	90	538,9	1840	463,8	1,52	5,18	1,31	355,3	2,22	5,46	
	-25	-13	55	131	32	89,6	55	131	403,0	1376	346,8	1,18	4,02	1,01	342,6	2,18	5,02	cecomaf LBP
	-35	-31	40	104	20	68	40	104	304,9	1041	262,4	1,18	4,03	1,02	258,2	1,95	3,48	EN12900 LBP
	-23,3	-10	48,9	120	4,44	40	48,9	120	440,2	1503	378,9	1,27	4,34	1,09	346,6	2,19	6,10	ARI540 LBP
	-23,3	-10	40,6	105	32,2	90	32,2	90	589,5	2013	507,3	1,77	6,06	1,53	332,4	2,15	5,97	AHAM LBP
	-35	-31	45	113	32	89,6	45	113	291,4	995	250,8	1,11	3,80	0,96	262,0	1,96	3,27	opt

### Performance tables

220-240V/50Hz 1~, RSIR, fan 3m/s, VDE, CCC

	pe	Cooling capacity			COP	EER	P1	I	m		
	[°C]	[°F]	[W]	[Btu/h]	[kcal/h]	[W/W]	[Btu/Wh]	[kcal/Wh]	[W]	[A]	[kg/h]
[°C / °F]	-35	-31	291,4	995	250,8	1,11	3,80	0,96	262,0	1,96	3,27
cond. pressure	-30	-22	375,5	1282	323,1	1,28	4,36	1,10	294,4	2,04	4,22
pc= 45/113	-25	-13	477,1	1629	410,6	1,45	4,96	1,25	328,6	2,14	5,38
return gas temp.	-23,3	-10	515,7	1761	443,8	1,51	5,17	1,30	340,5	2,18	5,82
RGT= 32/90	-20	-4	596,6	2037	513,4	1,64	5,60	1,41	364,0	2,25	6,76
liquid temp	-15	5	734,3	2508	632,0	1,84	6,27	1,58	400,1	2,38	8,35
Tliq= 45/113	-5	23	1066,2	3641	917,6	2,26	7,71	1,94	472,3	2,65	12,28
[°C / °F]	-35	-31	242,7	829	208,9	0,91	3,10	0,78	267,6	1,97	3,00
cond. pressure	-30	-22	314,8	1075	271,0	1,04	3,54	0,89	303,5	2,06	3,91
pc= 55/131	-25	-13	403,0	1376	346,8	1,18	4,02	1,01	342,6	2,18	5,02
return gas temp	-23,3	-10	436,6	1491	375,8	1,22	4,18	1,05	356,5	2,23	5,44
RGT= 32/90	-20	-4	507,4	1733	436,7	1,32	4,51	1,14	384,3	2,32	6,35
liquid temp	-15	5	628,6	2147	540,9	1,47	5,01	1,26	428,3	2,49	7,90
Tliq= 55/131	-5	23	922,4	3150	793,9	1,77	6,05	1,52	521,0	2,85	11,75