

Model

Designation	NLE11MF.2	220-240V/50Hz 1~	Sales code:	105G7101
-------------	------------------	------------------	-------------	-----------------

Compressor design

Oil type	Polyolester	Refrigerant(s)	R134a, R513A
Oil viscosity	19,2cST	Displacement	11,15cm ³ / 0,68cu.in
Oil quantity	295cm ³ / 10fl.oz	Compressors on pallet	80
Refr. charge - tech. limit	600g / 21,2oz		
Free gas volume comp.	2360cm ³ / 79,8fl.oz		
Weight	10,9kg / 24lbs		
Motor protection	1# internal		
Winding resistance main	8,84Ω (at 25°C)		
Winding resistance aux	19,04Ω (at 25°C)		
Max. winding temp.	125°C / 257°F		
Max. discharge temp.	120°C / 248°F		



General - Configurations with NLE11MF.2

	Conf. 1	Conf. 2	Conf. 3	Conf. 4	Conf. 5
Motorconfiguration	CSIR	RSIR	CSIR	RSIR	RSCR
Power supply (nominal)	220-230V/50Hz	220-230V/50Hz	220-240V/50Hz	220-240V/50Hz	220-240V/50Hz
Number of phases	1	1	1	1	1
Voltage range	198-242V	198-242V	198-254V	198-254V	198-254V
Approvals	VDE	VDE	VDE	VDE	VDE
Starting torque	HST	LST	HST	LST	LST
Note	- / -				

Applications with NLE11MF.2

	Conf. 1	Conf. 2	Conf. 3	Conf. 4	Conf. 5
Refrigerant	R134a	R134a	R134a	R134a	R134a
Application	MBP	MBP	MBP	MBP	MBP
System cooling	fan 3m/s	fan 3m/s	fan 3m/s	fan 3m/s	fan 3m/s
Hot gas defrost	OK	OK	OK	OK	OK
Long interval pull down	OK	OK	OK	OK	OK

Electrical data - Configurations with NLE11MF.2

	Conf. 1	Conf. 2	Conf. 3	Conf. 4	Conf. 5
Starting device type	relay	PTC	relay	PTC	PTC
Run capacitor	- / -	- / -	- / -	- / -	4μF
Start capacitor	80μF	- / -	80μF	- / -	- / -
LRA (locked rotor amps / 4s)	13,12A	11,43A	13,12A	11,43A	11,43A
RLA (rated load amps / 1s)	2,29A	2,29A	2,29A	2,29A	2,29A
Cut in current	13,12A	15,67A	13,12A	15,67A	15,67A
IP class	21	21	21	21	21

Model

Designation

NLE11MF.2 220-240V/50Hz 1~

Sales code:

105G7101

Compressor dimensions

Housing	A Height	203mm / 7,99in
	B Height	197mm / 7,76in
	C Length shell	205mm / 8,07in
	D Length w. cover	254mm / 10in
	E Width	166mm / 6,54in

Connectors		Suction	Discharge	Process
		X	Y	Z
Diameter	[mm]	øi 8,11-8,29	øi 6,11-6,29	øi 6,11-6,29
(i:inside, o:outside)	[in]	øi 0,32-0,33	øi 0,24-0,25	øi 0,24-0,25
Material		copper	copper	copper
Horizontal angle	±2°	0°	0°	0°
Vertical angle	±2°	15°	15°	155°
Position l/h/w	[mm]	132/69/56	94/99/86	-111/92/72
	[in]	5,2/2,7/2,2	3,7/3,9/3,4	-4,4/3,6/2,8
Straight tube l.	[mm]	12	12	12
	[in]	0,5	0,5	0,5

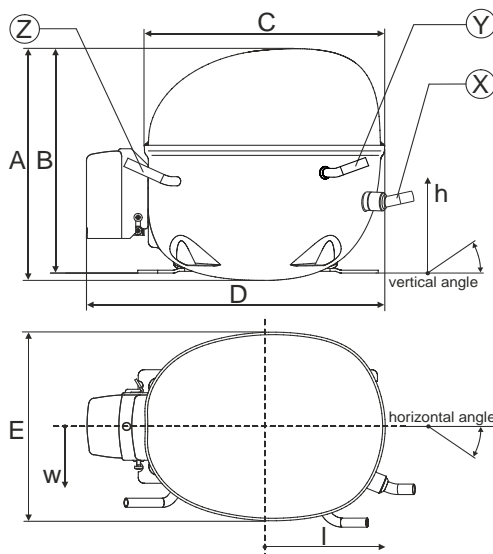

Compressor fixation

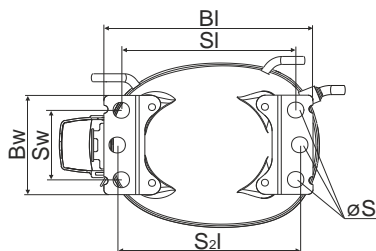

Baseplate	[mm]	[inch]
BI	204	8.03
Bw	100	3.94
Small holes	[mm]	[inch]
SI	170	6.7
Sw	70	2.76
S2l	178	7
øS	ø 16	ø 0.63

Bolt joint

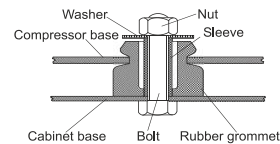

Snap-on

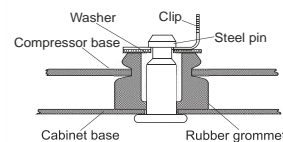

Mounting accessories

	one comp.	multi pack
Bolt joint M6 ø16mm	118-1917	118-1918
Bolt joint ø1/4" ø16mm	118-1946	
Snap-on ø7,3 ø16mm	118-1947	118-1919

Model

Designation	NLE11MF.2	220-230V/50Hz	Conf. 1	Sales code:	105G7101
-------------	-----------	---------------	---------	-------------	----------

Configuration

Motorconfiguration	CSIR
Power supply (nominal)	220-230V/50Hz 1~
Refrigerant	R134a
Application	MBP
Voltage range	198-242V
Starting torque	HST
Approvals	VDE

Electrical accessories / wiring diagram

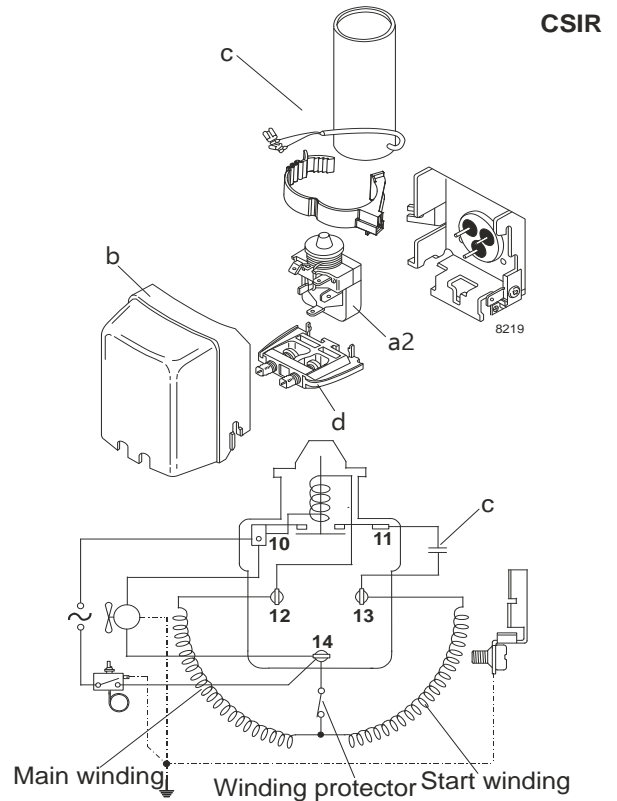

Ambient temperatures / system cooling

Ambient temperature min.:	10°C / 50°F
Ambient temperature max.:	43°C / 110°F

System cooling (n/a: outside limits)			
T ambient	LBP	MBP	HBP
32°C / 90°F	n/a	fan 3m/s	n/a
38°C / 100°F	n/a	fan 3m/s	n/a
43°C / 110°F	n/a	fan 3m/s	n/a

Operation pressure range

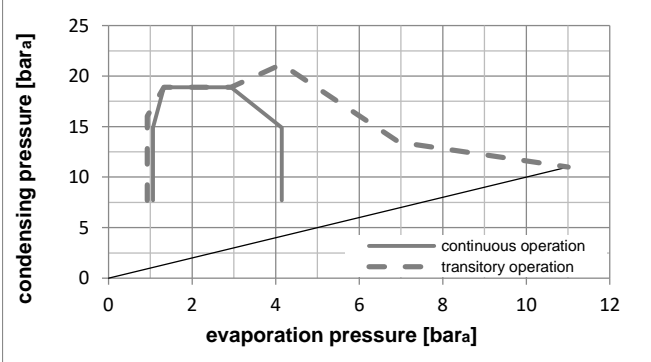
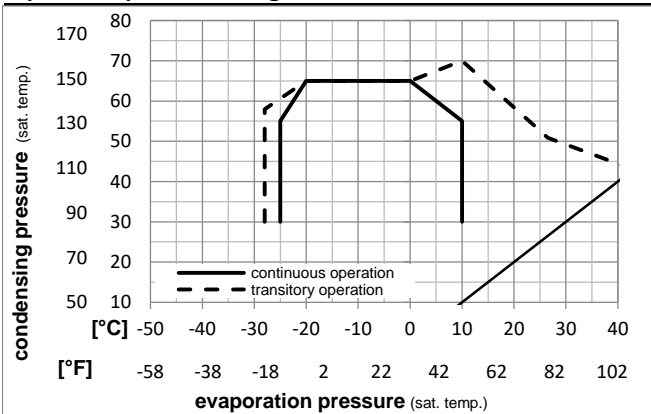

Components

a2	assy. relay	117U6003
c	start capacitor (80µF)	117U5015
b	plastic cover	103N2010
d	cord relief	103N1010

Alternative components

b	plastic cover	103N2011
---	---------------	----------

Model

Designation **NLE11MF.2 220-230V/50Hz** Conf. 1 Sales code: **105G7101**

Optimization + standard conditions

R134a, 220V/50Hz, CSIR, fan 3m/s, VDE

	Evaporating pressure (saturation temperature)				Cooling capacity			COP	EER	Power consumption			ASHRAE MBP					
	pe	pc	RGT	Tliq	[W]	[Btu/h]	[kcal/h]			P1	I	m						
	[°C]	[°F]	[°C]	[°F]				[W/W]	[Btu/Wh]	[kcal/Wh]	[W]	[A]	[kg/h]					
	-6,66	20	54,4	130	35	95	46,1	115	681,3	2327	586,3	1,88	6,42	1,62	362,6	2,19	14,86	ASHRAE MBP
	-10	14	55	131	32	89,6	55	131	527,2	1800	453,7	1,57	5,38	1,35	334,9	2,11	12,75	cecomaf MBP
	-10	14	45	113	20	68	45	113	600,7	2051	516,9	1,90	6,50	1,64	315,7	2,05	14,06	EN12900 MBP
	-6,66	20	48,9	120	18,3	65	48,9	120	651,3	2224	560,5	1,87	6,37	1,61	349,1	2,15	16,09	ARI540 MBP
	-10	14	45	113	32	89,6	45	113	623,2	2128	536,3	1,97	6,74	1,70	315,7	2,05	13,64	opt
	-25	-13	45	113	32	89,6	45	113	296,7	1013	255,3	1,34	4,58	1,15	221,1	1,78	6,43	opt

Performance tables

R134a, 220V/50Hz, CSIR, fan 3m/s, VDE

	pe	Cooling capacity			COP	EER	P1	I	m		
	[°C]	[°F]	[W]	[Btu/h]						[kcal/h]	
[°C / °F]	-25	-13	296,7	1013	255,3	1,34	4,58	1,15	221,1	1,78	6,43
cond. pressure	-20	-4	386,5	1320	332,7	1,55	5,28	1,33	250,0	1,89	8,40
pc= 45/113	-15	5	494,7	1690	425,8	1,76	5,99	1,51	281,9	1,97	10,78
return gas temp.	-10	14	623,2	2128	536,3	1,97	6,74	1,70	315,7	2,05	13,64
RGT= 32/90	0	32	948,9	3241	816,6	2,46	8,42	2,12	385,0	2,23	20,98
liquid temp	5	41	1150,1	3928	989,8	2,75	9,38	2,36	418,5	2,35	25,60
Tliq= 45/113	10	50	1379,5	4711	1187,2	3,07	10,47	2,64	449,9	2,49	30,95
[°C / °F]	-25	-13	242,2	827	208,4	1,08	3,69	0,93	223,9	1,78	5,79
cond. pressure	-20	-4	319,3	1090	274,8	1,24	4,25	1,07	256,6	1,89	7,66
pc= 55/131	-15	5	413,6	1413	356,0	1,41	4,80	1,21	294,0	2,00	9,96
return gas temp	-10	14	527,2	1800	453,7	1,57	5,38	1,35	334,9	2,11	12,75
RGT= 32/90	0	32	819,9	2800	705,6	1,94	6,61	1,67	423,4	2,39	20,06
liquid temp	5	41	1003,0	3425	863,2	2,14	7,30	1,84	468,9	2,58	24,72
Tliq= 55/131	10	50	1213,2	4143	1044,1	2,36	8,06	2,03	514,0	2,80	30,16

Model

Designation	NLE11MF.2	220-230V/50Hz	Conf. 2	Sales code:	105G7101
-------------	-----------	---------------	---------	-------------	----------

Configuration

Motorconfiguration	RSIR
Power supply (nominal)	220-230V/50Hz 1~
Refrigerant	R134a
Application	MBP
Voltage range	198-242V
Starting torque	LST
Approvals	VDE

Electrical accessories / wiring diagram

RSIR

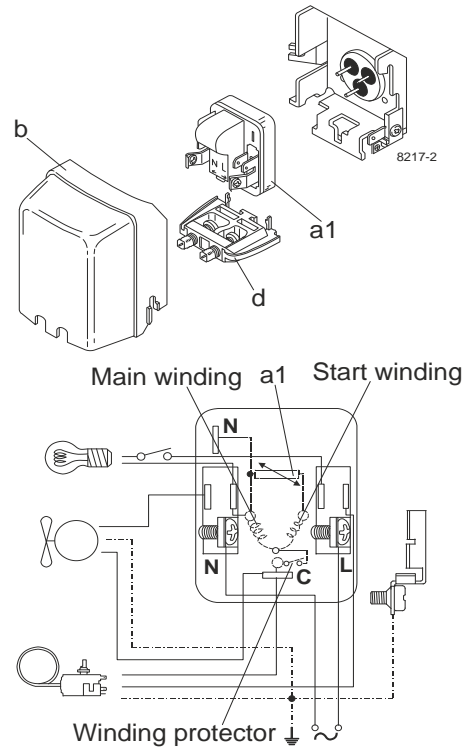

Ambient temperatures / system cooling

Ambient temperature min.:	10°C / 50°F
Ambient temperature max.:	43°C / 110°F

System cooling (n/a: outside limits)			
T ambient	LBP	MBP	HBP
32°C / 90°F	n/a	fan 3m/s	n/a
38°C / 100°F	n/a	fan 3m/s	n/a
43°C / 110°F	n/a	fan 3m/s	n/a

Operation pressure range

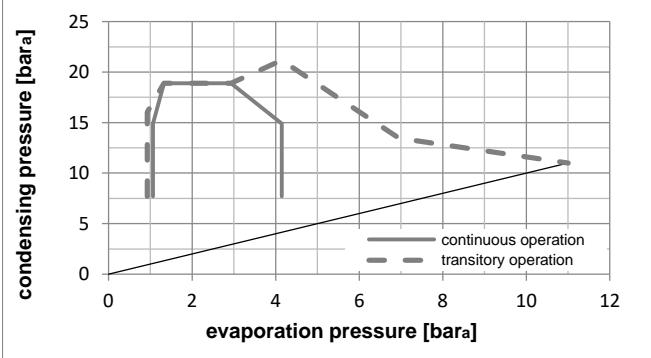
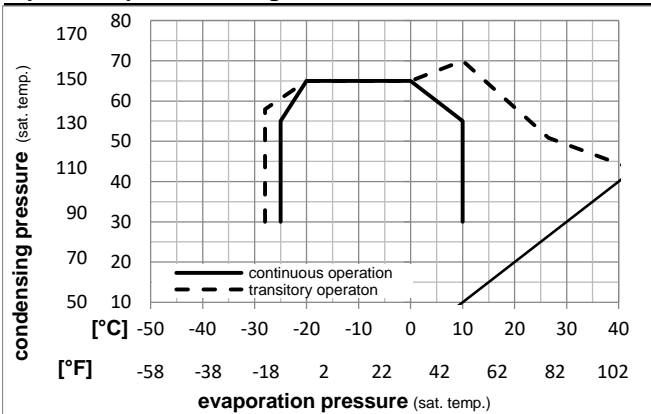

Components

a1	e-PTC starter (220V, 250hm, 4.8mm)	103N0050
b	plastic cover	103N2010
d	cord relief	103N1010

Alternative components

b	plastic cover	103N2011
---	---------------	----------

Model

Designation **NLE11MF.2 220-230V/50Hz** Conf. 2 Sales code: **105G7101**

Optimization + standard conditions

R134a, 220V/50Hz, RSIR, fan 3m/s, VDE

		Evaporating pressure (saturation temperature)				Condensing pressure (saturation temperature)						Power consumption			
		Return gas temp.				Liquid temp.						Current consumption		Ref. mass flow	
		Cooling capacity				COP		EER		P1	I	m			
	pe	pc	RGT	Tliq	[W]	[Btu/h]	[kcal/h]	[W/W]	[Btu/Wh]	[kcal/Wh]	[W]	[A]	[kg/h]		
[°C]	-6,7	54,4	35	46,1	681,3	2327	586,3	1,88	6,42	1,62	362,6	2,19	14,86	ASHRAE MBP	
[°F]	20	130	95	115											
[°C]	-10	55	32	55	527,2	1800	453,7	1,57	5,38	1,35	334,9	2,11	12,75	cecmaf MBP	
[°F]	14	131	89,6	131											
[°C]	-10	45	20	45	600,7	2051	516,9	1,90	6,50	1,64	315,7	2,05	14,06	EN12900 MBP	
[°F]	14	113	68	113											
[°C]	-6,7	48,9	18,3	48,9	651,3	2224	560,5	1,87	6,37	1,61	349,1	2,15	16,09	ARI540 MBP	
[°F]	20	120	65	120											
[°C]	-10	45	32	45	623,2	2128	536,3	1,97	6,74	1,70	315,7	2,05	13,64	opt	
[°F]	14	113	89,6	113											
[°C]	-25	45	32	45	296,7	1013	255,3	1,34	4,58	1,15	221,1	1,78	6,43	opt	
[°F]	-13	113	89,6	113											

Performance tables

R134a, 220V/50Hz, RSIR, fan 3m/s, VDE

	pe	Cooling capacity			COP		EER		P1	I	m
	[°C]	[°F]	[W]	[Btu/h]	[kcal/h]	[W/W]	[Btu/Wh]	[kcal/Wh]	[W]	[A]	[kg/h]
[°C / °F]	-25	-13	296,7	1013	255,3	1,34	4,58	1,15	221,1	1,78	6,43
cond. pressure	-20	-4	386,5	1320	332,7	1,55	5,28	1,33	250,0	1,89	8,40
pc= 45/113	-15	5	494,7	1690	425,8	1,76	5,99	1,51	281,9	1,97	10,78
return gas temp.	-10	14	623,2	2128	536,3	1,97	6,74	1,70	315,7	2,05	13,64
RGT= 32/90	0	32	948,9	3241	816,6	2,46	8,42	2,12	385,0	2,23	20,98
liquid temp	5	41	1150,1	3928	989,8	2,75	9,38	2,36	418,5	2,35	25,60
Tliq= 45/113	10	50	1379,5	4711	1187,2	3,07	10,47	2,64	449,9	2,49	30,95
[°C / °F]	-25	-13	242,2	827	208,4	1,08	3,69	0,93	223,9	1,78	5,79
cond. pressure	-20	-4	319,3	1090	274,8	1,24	4,25	1,07	256,6	1,89	7,66
pc= 55/131	-15	5	413,6	1413	356,0	1,41	4,80	1,21	294,0	2,00	9,96
return gas temp	-10	14	527,2	1800	453,7	1,57	5,38	1,35	334,9	2,11	12,75
RGT= 32/90	0	32	819,9	2800	705,6	1,94	6,61	1,67	423,4	2,39	20,06
liquid temp	5	41	1003,0	3425	863,2	2,14	7,30	1,84	468,9	2,58	24,72
Tliq= 55/131	10	50	1213,2	4143	1044,1	2,36	8,06	2,03	514,0	2,80	30,16

Model

Designation	NLE11MF.2	220-240V/50Hz	Conf. 3	Sales code:	105G7101
-------------	-----------	---------------	---------	-------------	----------

Configuration

Motorconfiguration	CSIR
Power supply (nominal)	220-240V/50Hz 1~
Refrigerant	R134a
Application	MBP
Voltage range	198-254V
Starting torque	HST
Approvals	VDE

Electrical accessories / wiring diagram

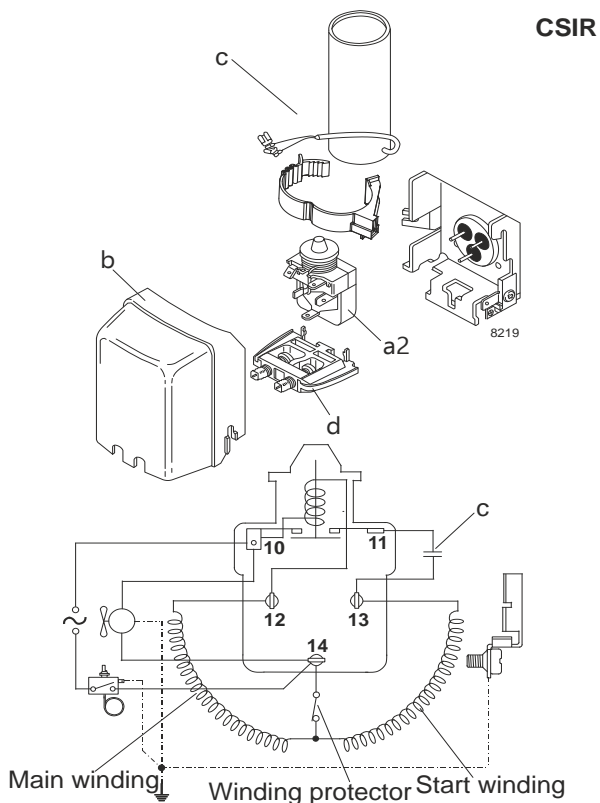

Ambient temperatures / system cooling

Ambient temperature min.:	10°C / 50°F
Ambient temperature max.:	43°C / 110°F

System cooling (n/a: outside limits)			
T ambient	LBP	MBP	HBP
32°C / 90°F	n/a	fan 3m/s	n/a
38°C / 100°F	n/a	fan 3m/s	n/a
43°C / 110°F	n/a	fan 3m/s	n/a

Operation pressure range

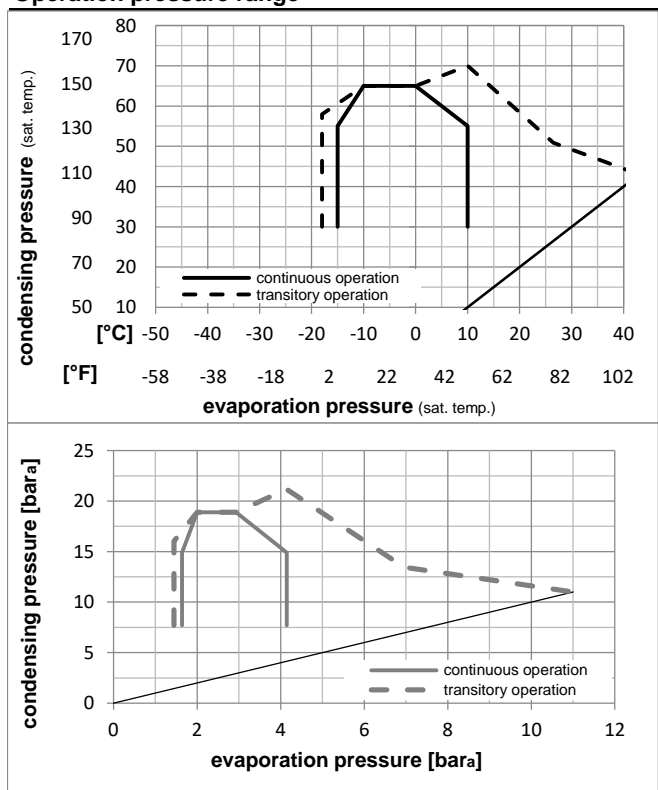

Components

a2	assy. relay	117U6003
c	start capacitor (80µF)	117U5015
b	plastic cover	103N2010
d	cord relief	103N1010

Alternative components

b	plastic cover	103N2011
---	---------------	----------

Model

Designation **NLE11MF.2 220-240V/50Hz** Conf. **3** Sales code: **105G7101**

Optimization + standard conditions

R134a, 220V/50Hz, CSIR, fan 3m/s, VDE

	Evaporating pressure (saturation temperature)				Condensing pressure (saturation temperature)						Power consumption			ASHRAE MBP			
	pe	pc	RGT	Tliq	W	[Btu/h]	[kcal/h]	COP	EER	[kcal/Wh]	P1	I	Ref. mass flow m				
	[°C]	[°F]	[°C]	[°F]	[W]	[Btu/h]	[kcal/h]	[W/W]	[Btu/Wh]	[kcal/Wh]	[W]	[A]	[kg/h]				
	-6,66	20	54,4	130	35	46,1	115	681,3	2327	586,3	1,88	6,42	1,62	362,6	2,19	14,86	ASHRAE MBP
	-10	14	55	131	32	55	131	527,2	1800	453,7	1,57	5,38	1,35	334,9	2,11	12,75	cecomaf MBP
	-10	14	45	113	20	45	113	600,7	2051	516,9	1,90	6,50	1,64	315,7	2,05	14,06	EN12900 MBP
	-6,66	20	48,9	120	18,3	48,9	120	651,3	2224	560,5	1,87	6,37	1,61	349,1	2,15	16,09	ARI540 MBP
	-10	14	45	113	32	45	113	623,2	2128	536,3	1,97	6,74	1,70	315,7	2,05	13,64	opt
	-25	-13	45	113	32	45	113	296,7	1013	255,3	1,34	4,58	1,15	221,1	1,78	6,43	opt

Performance tables

R134a, 220V/50Hz, CSIR, fan 3m/s, VDE

	pe	Cooling capacity			COP	EER	P1	I	m		
	[°C]	[°F]	[W]	[Btu/h]	[kcal/h]	[W/W]	[Btu/Wh]	[kcal/Wh]	[W]	[A]	[kg/h]
[°C / °F]	-15	5	494,7	1690	425,8	1,76	5,99	1,51	281,9	1,97	10,78
cond. pressure	-10	14	623,2	2128	536,3	1,97	6,74	1,70	315,7	2,05	13,64
pc= 45/113	-6,7	20	720,0	2459	619,7	2,13	7,26	1,83	338,6	2,11	15,81
return gas temp.	0	32	948,9	3241	816,6	2,46	8,42	2,12	385,0	2,23	20,98
RGT= 32/90	5	41	1150,1	3928	989,8	2,75	9,38	2,36	418,5	2,35	25,60
liquid temp	7,2	45	1247,4	4260	1073,5	2,88	9,85	2,48	432,6	2,41	27,86
Tliq= 45/113	10	50	1379,5	4711	1187,2	3,07	10,47	2,64	449,9	2,49	30,95
[°C / °F]	-15	5	413,6	1413	356,0	1,41	4,80	1,21	294,0	2,00	9,96
cond. pressure	-10	14	527,2	1800	453,7	1,57	5,38	1,35	334,9	2,11	12,75
pc= 55/131	-6,7	20	613,6	2096	528,1	1,69	5,77	1,45	363,4	2,19	14,89
return gas temp	0	32	819,9	2800	705,6	1,94	6,61	1,67	423,4	2,39	20,06
RGT= 32/90	5	41	1003,0	3425	863,2	2,14	7,30	1,84	468,9	2,58	24,72
liquid temp	7,2	45	1092,1	3730	939,8	2,23	7,63	1,92	488,9	2,67	27,01
Tliq= 55/131	10	50	1213,2	4143	1044,1	2,36	8,06	2,03	514,0	2,80	30,16

Model

Designation	NLE11MF.2	220-240V/50Hz	Conf. 4	Sales code:	105G7101
-------------	-----------	---------------	---------	-------------	----------

Configuration

Motorconfiguration	RSIR
Power supply (nominal)	220-240V/50Hz 1~
Refrigerant	R134a
Application	MBP
Voltage range	198-254V
Starting torque	LST
Approvals	VDE

Electrical accessories / wiring diagram

RSIR

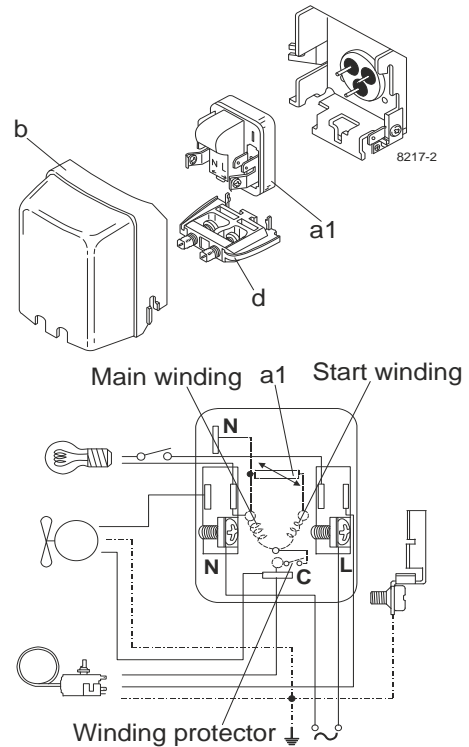

Ambient temperatures / system cooling

Ambient temperature min.:	10°C / 50°F
Ambient temperature max.:	43°C / 110°F

System cooling (n/a: outside limits)			
T ambient	LBP	MBP	HBP
32°C / 90°F	n/a	fan 3m/s	n/a
38°C / 100°F	n/a	fan 3m/s	n/a
43°C / 110°F	n/a	fan 3m/s	n/a

Operation pressure range

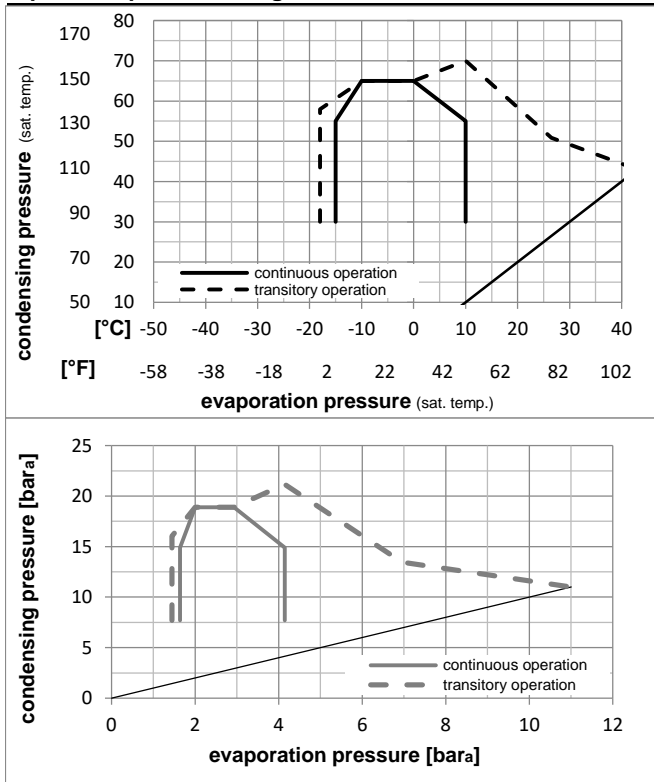

Components

a1	e-PTC starter (220V, 250hm, 4.8mm)	103N0050
b	plastic cover	103N2010
d	cord relief	103N1010

Alternative components

b	plastic cover	103N2011
---	---------------	----------

Model

Designation **NLE11MF.2 220-240V/50Hz** Conf. **4** Sales code: **105G7101**

Optimization + standard conditions

R134a, 220V/50Hz, RSIR, fan 3m/s, VDE

	Evaporating pressure (saturation temperature)				Condensing pressure (saturation temperature)						Power consumption			ASHRAE MBP				
	pe	pc	RGT	Tliq	W	[Btu/h]	[kcal/h]	COP	EER	[kcal/Wh]	P1	I	Ref. mass flow m					
	[°C]	[°F]	[°C]	[°F]	[W]	[Btu/h]	[kcal/h]	[W/W]	[Btu/Wh]	[kcal/Wh]	[W]	[A]	[kg/h]					
	-6,66	20	54,4	130	35	95	46,1	115	681,3	2327	586,3	1,88	6,42	1,62	362,6	2,19	14,86	ASHRAE MBP
	-10	14	55	131	32	89,6	55	131	527,2	1800	453,7	1,57	5,38	1,35	334,9	2,11	12,75	cecomaf MBP
	-10	14	45	113	20	68	45	113	600,7	2051	516,9	1,90	6,50	1,64	315,7	2,05	14,06	EN12900 MBP
	-6,66	20	48,9	120	18,3	65	48,9	120	651,3	2224	560,5	1,87	6,37	1,61	349,1	2,15	16,09	ARI540 MBP
	-10	14	45	113	32	89,6	45	113	623,2	2128	536,3	1,97	6,74	1,70	315,7	2,05	13,64	opt
	-25	-13	45	113	32	89,6	45	113	296,7	1013	255,3	1,34	4,58	1,15	221,1	1,78	6,43	opt

Performance tables

R134a, 220V/50Hz, RSIR, fan 3m/s, VDE

	pe	Cooling capacity			COP	EER	P1	I	m		
	[°C]	[°F]	[W]	[Btu/h]	[kcal/h]	[W/W]	[Btu/Wh]	[kcal/Wh]	[W]	[A]	[kg/h]
[°C / °F]	-15	5	494,7	1690	425,8	1,76	5,99	1,51	281,9	1,97	10,78
cond. pressure	-10	14	623,2	2128	536,3	1,97	6,74	1,70	315,7	2,05	13,64
pc= 45/113	-6,7	20	720,0	2459	619,7	2,13	7,26	1,83	338,6	2,11	15,81
return gas temp.	0	32	948,9	3241	816,6	2,46	8,42	2,12	385,0	2,23	20,98
RGT= 32/90	5	41	1150,1	3928	989,8	2,75	9,38	2,36	418,5	2,35	25,60
liquid temp	7,2	45	1247,4	4260	1073,5	2,88	9,85	2,48	432,6	2,41	27,86
Tliq= 45/113	10	50	1379,5	4711	1187,2	3,07	10,47	2,64	449,9	2,49	30,95
[°C / °F]	-15	5	413,6	1413	356,0	1,41	4,80	1,21	294,0	2,00	9,96
cond. pressure	-10	14	527,2	1800	453,7	1,57	5,38	1,35	334,9	2,11	12,75
pc= 55/131	-6,7	20	613,6	2096	528,1	1,69	5,77	1,45	363,4	2,19	14,89
return gas temp	0	32	819,9	2800	705,6	1,94	6,61	1,67	423,4	2,39	20,06
RGT= 32/90	5	41	1003,0	3425	863,2	2,14	7,30	1,84	468,9	2,58	24,72
liquid temp	7,2	45	1092,1	3730	939,8	2,23	7,63	1,92	488,9	2,67	27,01
Tliq= 55/131	10	50	1213,2	4143	1044,1	2,36	8,06	2,03	514,0	2,80	30,16

Model

Designation	NLE11MF.2	220-240V/50Hz	Conf. 5	Sales code:	105G7101
-------------	-----------	---------------	---------	-------------	----------

Configuration

Motorconfiguration	RSCR
Power supply (nominal)	220-240V/50Hz 1~
Refrigerant	R134a
Application	MBP
Voltage range	198-254V
Starting torque	LST
Approvals	VDE

Electrical accessories / wiring diagram

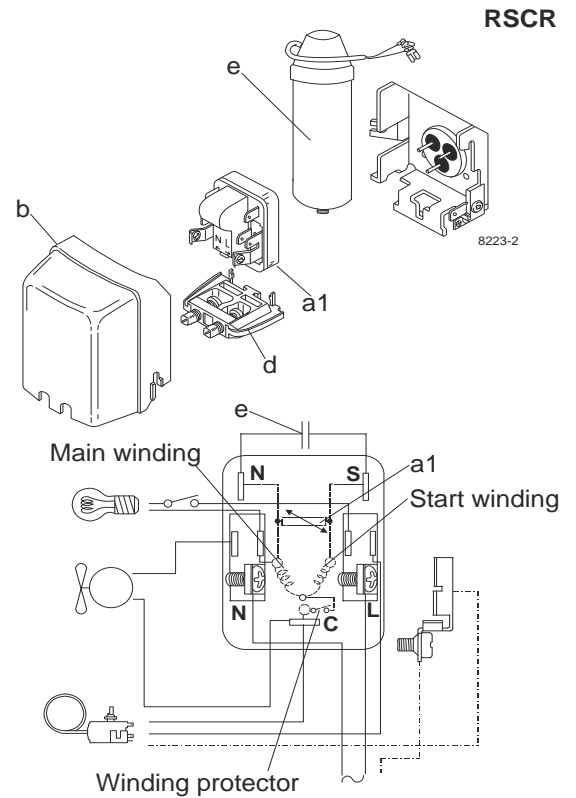

Ambient temperatures / system cooling

Ambient temperature min.:	10°C / 50°F
Ambient temperature max.:	43°C / 110°F

System cooling (n/a: outside limits)			
T ambient	LBP	MBP	HBP
32°C / 90°F	n/a	fan 3m/s	n/a
38°C / 100°F	n/a	fan 3m/s	n/a
43°C / 110°F	n/a	fan 3m/s	n/a

Operation pressure range

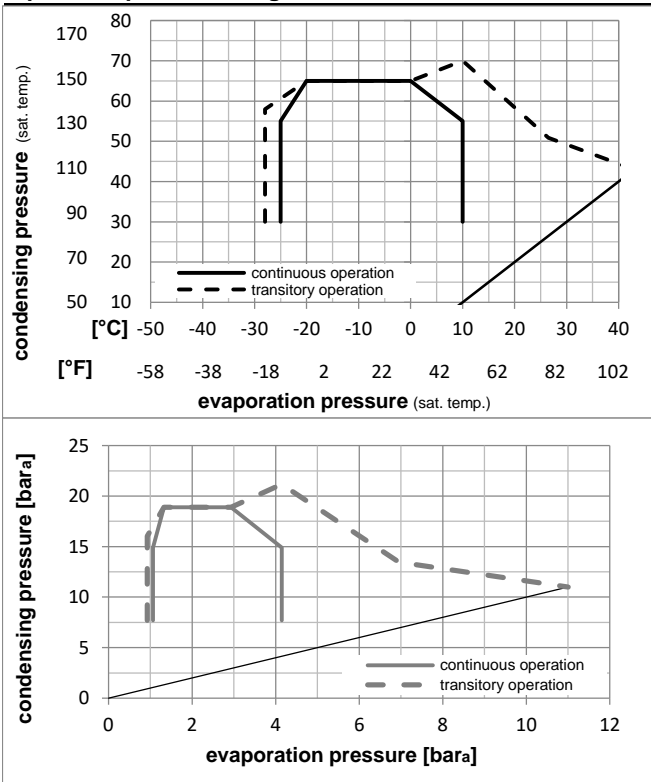

Components

a1	e-PTC starter (220V, 250hm, 4.8mm)	103N0050
e	run capacitor (4μF, 4.8mm)	117-7119
b	plastic cover	103N2010
d	cord relief	103N1010
	bracket for run capacitor	117-0300
	screw M4x8mm	117-0301

Alternative components

b	plastic cover	103N2011
---	---------------	----------

Model

Designation

NLE11MF.2 220-240V/50Hz

Conf. 5

Sales code:

105G7101

Optimization + standard conditions

R134a, 220V/50Hz, RSCR, fan 3m/s, VDE

	Evaporating pressure (saturation temperature)				Condensing pressure (saturation temperature)						Power consumption			ASHRAE MBP				
	pe	pc	RGT	Tliq	Cooling capacity			COP	EER	P1	I	Ref. mass flow m						
	[°C]	[°F]	[°C]	[°F]	[W]	[Btu/h]	[kcal/h]	[W/W]	[Btu/Wh]	[kcal/Wh]	[W]	[A]	[kg/h]					
	-6,66	20	54,4	130	35	95	46,1	115	690,3	2357	594,1	2,02	6,91	1,74	341,0	2,06	15,06	ASHRAE MBP
	-10	14	55	131	32	89,6	55	131	534,2	1824	459,7	1,70	5,79	1,46	315,0	1,99	12,92	cecomaf MBP
	-10	14	45	113	20	68	45	113	608,6	2079	523,8	2,05	7,00	1,76	296,9	1,93	14,25	EN12900 MBP
	-6,66	20	48,9	120	18,3	65	48,9	120	659,9	2254	567,9	2,01	6,86	1,73	328,4	2,02	16,30	ARI540 MBP
	-10	14	45	113	32	89,6	45	113	631,4	2156	543,4	2,13	7,26	1,83	296,9	1,93	13,82	opt
	-25	-13	45	113	32	89,6	45	113	300,6	1027	258,7	1,45	4,94	1,24	207,9	1,68	6,51	opt

Performance tables

R134a, 220V/50Hz, RSCR, fan 3m/s, VDE

	pe	Cooling capacity			COP			EER			P1	I	m
	[°C]	[°F]	[W]	[Btu/h]	[kcal/h]	[W/W]	[Btu/Wh]	[kcal/Wh]	[W]	[A]	[kg/h]		
[°C / °F]	-25	-13	300,6	1027	258,7	1,45	4,94	1,24	207,9	1,68	6,51		
cond. pressure	-20	-4	391,6	1338	337,1	1,67	5,69	1,43	235,1	1,77	8,51		
pc= 45/113	-15	5	501,2	1712	431,4	1,89	6,46	1,63	265,1	1,86	10,93		
return gas temp.	-10	14	631,4	2156	543,4	2,13	7,26	1,83	296,9	1,93	13,82		
RGT= 32/90	0	32	961,4	3283	827,4	2,66	9,07	2,28	362,1	2,10	21,26		
liquid temp	5	41	1165,3	3980	1002,9	2,96	10,11	2,55	393,6	2,21	25,94		
Tliq= 45/113	10	50	1397,7	4773	1202,9	3,30	11,28	2,84	423,2	2,34	31,36		
[°C / °F]	-25	-13	245,4	838	211,2	1,17	3,98	1,00	210,6	1,68	5,87		
cond. pressure	-20	-4	323,5	1105	278,4	1,34	4,58	1,15	241,4	1,78	7,76		
pc= 55/131	-15	5	419,1	1431	360,7	1,52	5,18	1,30	276,5	1,88	10,09		
return gas temp	-10	14	534,2	1824	459,7	1,70	5,79	1,46	315,0	1,99	12,92		
RGT= 32/90	0	32	830,7	2837	714,9	2,09	7,12	1,80	398,2	2,25	20,32		
liquid temp	5	41	1016,3	3471	874,6	2,30	7,87	1,98	441,0	2,42	25,04		
Tliq= 55/131	10	50	1229,3	4198	1057,9	2,54	8,68	2,19	483,4	2,64	30,56		