

Model

Designation	NLE12.6MF.2 220-240V/50Hz 1~ 220-240V/60Hz 1~	Sales code:	105G6389
-------------	--	-------------	-----------------

Compressor design

Oil type	Polyolester	Refrigerant(s)	R134a, R513A
Oil viscosity	19,2cST	Displacement	12,55cm ³ / 0,77cu.in
Oil quantity	295cm ³ / 10fl.oz	Compressors on pallet	80
Refr. charge - tech. limit	600g / 21,2oz		
Free gas volume comp.	2360cm ³ / 79,8fl.oz		
Weight	11,5kg / 25,4lbs		
Motor protection	1# internal		
Winding resistance main	4,94Ω (at 25°C)		
Winding resistance aux	8,89Ω (at 25°C)		
Max. winding temp.	125°C / 257°F		
Max. discharge temp.	120°C / 248°F		



General - Configurations with NLE12.6MF.2

	Conf. 1	Conf. 2	Conf. 3	Conf. 4	Conf. 5
Motorconfiguration	CSIR	RSIR	RSCR	CSIR	RSCR
Power supply (nominal)	220-240V/50Hz	220-240V/50Hz	220-240V/50Hz	220-240V/60Hz	220-240V/60Hz
Number of phases	1	1	1	1	1
Voltage range	198-254V	198-254V	198-254V	198-254V	198-254V
Approvals	VDE	VDE	VDE	VDE	VDE
Starting torque	HST	LST	LST	HST	LST
Note	- / -				

Applications with NLE12.6MF.2

	Conf. 1	Conf. 2	Conf. 3	Conf. 4	Conf. 5
Refrigerant	R134a	R134a	R134a	R134a	R134a
Application	LBP+MBP	LBP+MBP	LBP+MBP	LBP	LBP
System cooling	fan 3m/s	fan 3m/s	fan 3m/s	fan 3m/s	fan 3m/s
Hot gas defrost	OK	OK	OK	OK	OK
Long interval pull down	OK	OK	OK	- / -	- / -

Electrical data - Configurations with NLE12.6MF.2

	Conf. 1	Conf. 2	Conf. 3	Conf. 4	Conf. 5
Starting device type	relay	PTC	PTC	relay	PTC
Run capacitor	- / -	- / -	4μF	- / -	4μF
Start capacitor	80μF	- / -	- / -	80μF	- / -
LRA (locked rotor amps / 4s)	13,65A	14,45A	14,2A	13,06A	12,87A
RLA (rated load amps / 1s)	2,8A	2,8A	2,5A	2,22A	2,03A
Cut in current	13,65A	19,4A	19,4A	13,06A	17,92A
IP class	21	21	21	21	21

Model

Designation

NLE12.6MF.2 220-240V/50Hz 1~ 220-240V/60Hz 1~

Sales code:

105G6389

Compressor dimensions

Housing	A Height	203mm / 7,99in
	B Height	197mm / 7,76in
	C Length shell	205mm / 8,07in
	D Length w. cover	254mm / 10in
	E Width	166mm / 6,54in

Connectors		Suction	Discharge	Process
		X	Y	Z
Diameter	[mm]	øi 8,11-8,29	øi 6,11-6,29	øi 6,11-6,29
(i:inside, o:outside)	[in]	øi 0,32-0,33	øi 0,24-0,25	øi 0,24-0,25
Material		copper	copper	copper
Horizontal angle	±2°	0°	0°	0°
Vertical angle	±2°	15°	15°	155°
Position l/h/w	[mm]	132/69/56	94/99/86	-111/92/72
	[in]	5,2/2,7/2,2	3,7/3,9/3,4	-4,4/3,6/2,8
Straight tube l.	[mm]	12	12	12
	[in]	0,5	0,5	0,5

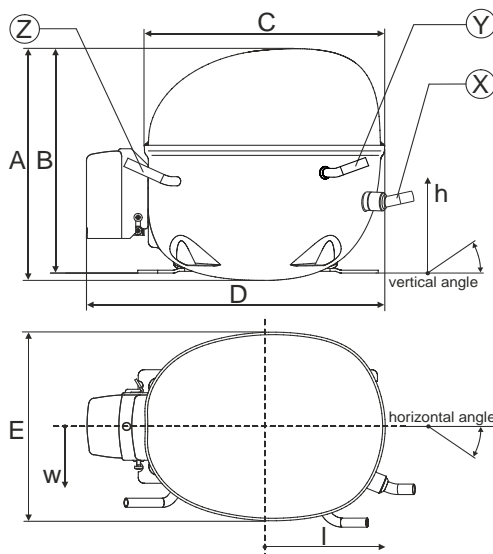

Compressor fixation

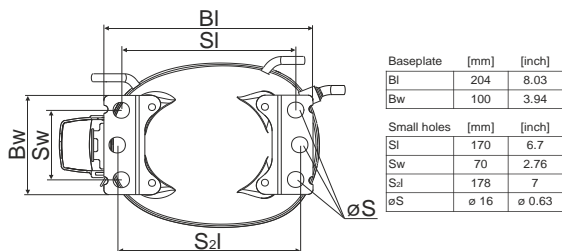

Bolt joint

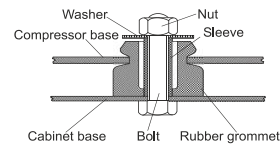

Snap-on

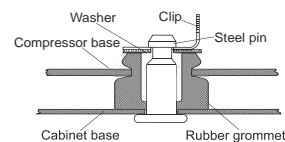

Mounting accessories

	one comp.	multi pack
Bolt joint M6 ø16mm	118-1917	118-1918
Bolt joint ø1/4" ø16mm	118-1946	
Snap-on ø7,3 ø16mm	118-1947	118-1919

Model

Designation	NLE12.6MF.2 220-240V/50Hz	Conf. 1	Sales code:	105G6389
-------------	----------------------------------	---------	-------------	-----------------

Configuration

Motorconfiguration	CSIR
Power supply (nominal)	220-240V/50Hz 1~
Refrigerant	R134a
Application	LBP+MBP
Voltage range	198-254V
Starting torque	HST
Approvals	VDE

Electrical accessories / wiring diagram

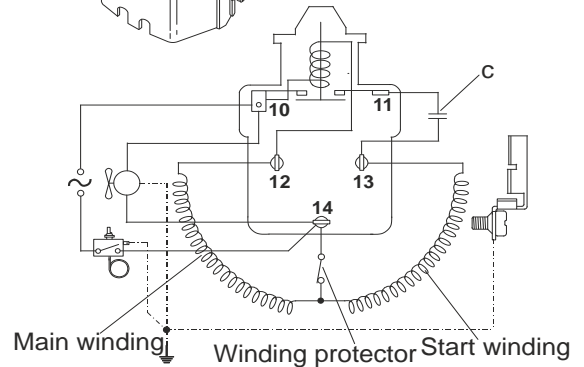
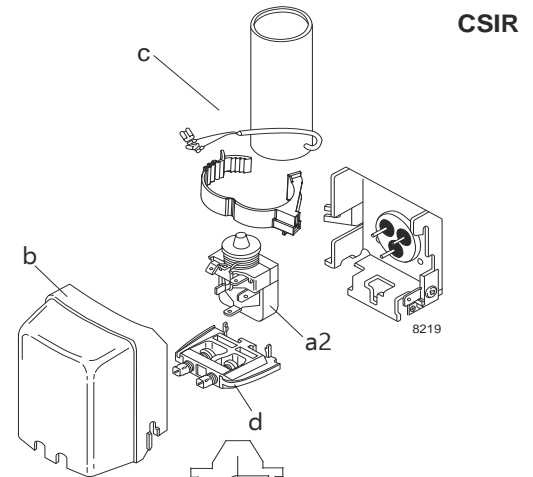

Ambient temperatures / system cooling

Ambient temperature min.:	10°C / 50°F
Ambient temperature max.:	43°C / 110°F

System cooling (n/a: outside limits)			
T ambient	LBP	MBP	HBP
32°C / 90°F	fan 3m/s	fan 3m/s	n/a
38°C / 100°F	fan 3m/s	fan 3m/s	n/a
43°C / 110°F	fan 3m/s	fan 3m/s	n/a

Operation pressure range

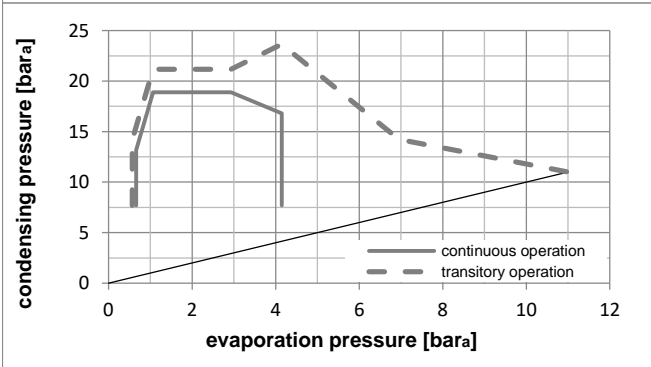
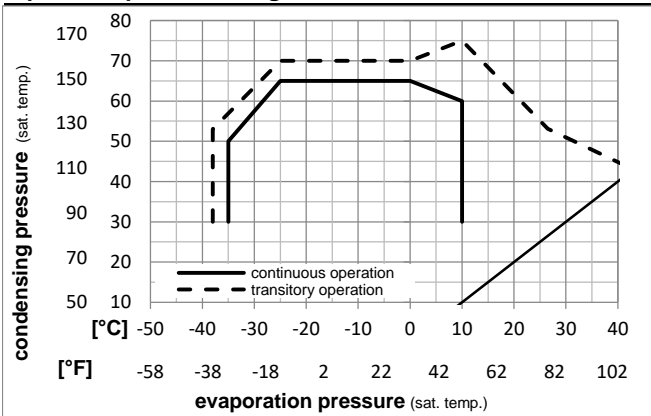

Components

a2	relay	117U6005
c	start capacitor (80µF)	117U5015
b	plastic cover	103N2010
d	cord relief	103N1010

Alternative components

b	plastic cover	103N2011
---	---------------	----------

Model

Designation

NLE12.6MF.2 220-240V/50Hz

Conf. 1

Sales code:

105G6389

Optimization + standard conditions

R134a, 220V/50Hz, CSIR, fan 3m/s, VDE

Evaporating pressure (saturation temperature)					Condensing pressure (saturation temperature)					Power consumption				ASHRAE MBP
Return gas temp.					Liquid temp.					Current consumption			Ref. mass flow ṁ	
Cooling capacity					COP		EER		P1	I	ṁ			
pe	pc	RGT	Tliq	[W]	[Btu/h]	[kcal/h]	[W/W]	[Btu/Wh]	[kcal/Wh]	[W]		[A]		
[°C]	-6,66	54,4	35	46,1	739,2	2524	636,1	1,98	6,77	1,71	372,9	2,43	16,13	ASHRAE MBP
[°F]	20	130	95	115										
[°C]	-10	55	32	55	567,0	1936	487,9	1,65	5,63	1,42	343,9	2,34	13,71	cecomaf MBP
[°F]	14	131	89,6	131										
[°C]	-10	45	20	45	657,3	2245	565,7	2,00	6,82	1,72	329,3	2,29	15,39	EN12900 MBP
[°F]	14	113	68	113										
[°C]	-6,66	48,9	18,3	48,9	711,2	2429	612,0	1,97	6,72	1,69	361,7	2,40	17,57	ARI540 MBP
[°F]	20	120	65	120										
[°C]	-10	45	32	45	681,9	2329	586,9	2,07	7,07	1,78	329,3	2,29	14,92	opt
[°F]	14	113	89,6	113										
[°C]	-25	45	32	45	312,2	1066	268,7	1,38	4,72	1,19	225,7	2,02	6,76	opt
[°F]	-13	113	89,6	113										

Performance tables

R134a, 220V/50Hz, CSIR, fan 3m/s, VDE

	pe	Cooling capacity			COP		EER		P1	I	m
	[°C]	[°F]	[W]	[Btu/h]	[kcal/h]	[W/W]	[Btu/Wh]	[kcal/Wh]	[W]	[A]	[kg/h]
[°C / °F]	-35	-31	197,3	674	169,8	1,12	3,82	0,96	176,4	1,97	4,26
cond. pressure	-25	-13	312,2	1066	268,7	1,38	4,72	1,19	225,7	2,02	6,76
pc= 45/113	-15	5	532,3	1818	458,1	1,82	6,23	1,57	291,9	2,18	11,60
return gas temp.	-10	14	681,9	2329	586,9	2,07	7,07	1,78	329,3	2,29	14,92
RGT= 32/90	0	32	1060,1	3620	912,3	2,60	8,87	2,23	408,2	2,56	23,44
liquid temp	5	41	1288,6	4401	1109,0	2,88	9,82	2,48	448,0	2,70	28,69
Tliq= 45/113	10	50	1543,6	5272	1328,4	3,17	10,82	2,73	487,0	2,85	34,64
[°C / °F]	-35	-31	198,1	677	170,5	1,12	3,81	0,96	177,6	1,98	4,71
cond. pressure	-25	-13	265,4	906	228,4	1,16	3,97	1,00	228,5	2,03	6,35
pc= 55/131	-15	5	439,7	1502	378,4	1,46	4,98	1,26	301,4	2,21	10,58
return gas temp	-10	14	567,0	1936	487,9	1,65	5,63	1,42	343,9	2,34	13,71
RGT= 32/90	0	32	901,8	3080	776,1	2,06	7,05	1,78	436,9	2,66	22,06
liquid temp	5	41	1109,3	3788	954,7	2,28	7,80	1,97	485,6	2,84	27,33
Tliq= 55/131	10	50	1343,6	4589	1156,3	2,51	8,58	2,16	534,7	3,04	33,40

Model

Designation **NLE12.6MF.2 220-240V/50Hz** Conf. 2 Sales code: **105G6389**

Configuration

Motorconfiguration **RSIR**
 Power supply (nominal) **220-240V/50Hz 1~**
 Refrigerant **R134a**
 Application **LBP+MBP**
 Voltage range **198-254V**
 Starting torque **LST**
 Approvals **VDE**

Electrical accessories / wiring diagram

RSIR

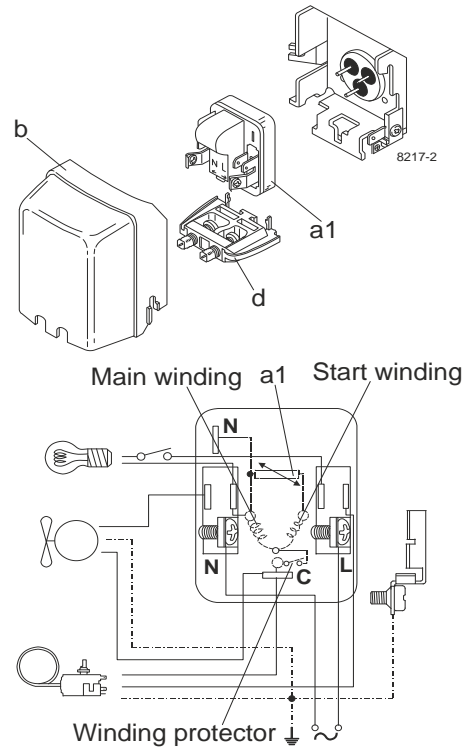

Ambient temperatures / system cooling

Ambient temperature min.: **10°C / 50°F**
 Ambient temperature max.: **43°C / 110°F**

System cooling (n/a: outside limits)			
T ambient	LBP	MBP	HBP
32°C / 90°F	fan 3m/s	fan 3m/s	n/a
38°C / 100°F	fan 3m/s	fan 3m/s	n/a
43°C / 110°F	fan 3m/s	fan 3m/s	n/a

Operation pressure range

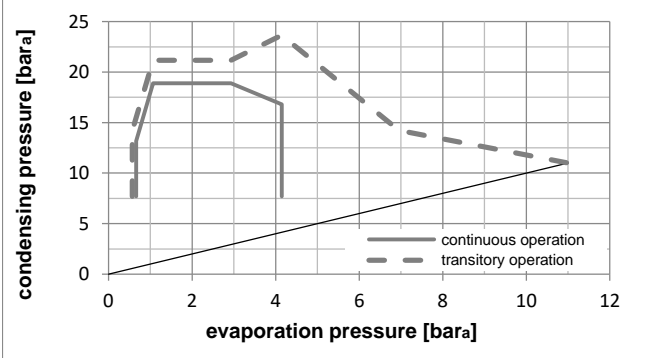
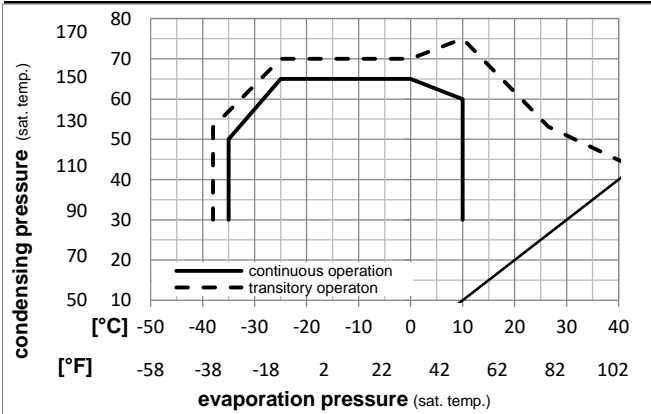

Components

a1	e-PTC starter (220V, 250hm, 4.8mm)	103N0050
b	plastic cover	103N2010
d	cord relief	103N1010

Alternative components

b	plastic cover	103N2011
---	---------------	----------

Model

Designation

NLE12.6MF.2 220-240V/50Hz

Conf. 2

Sales code:

105G6389

Optimization + standard conditions

R134a, 220V/50Hz, RSIR, fan 3m/s, VDE

	Evaporating pressure (saturation temperature)				Condensing pressure (saturation temperature)						Power consumption			ASHRAE MBP
	pe	pc	RGT	Tliq	Cooling capacity			COP	EER	P1	I	m	Ref. mass flow	
	[°C]	[°C]	[°C]	[°C]	[W]	[Btu/h]	[kcal/h]	[W/W]	[Btu/Wh]	[kcal/Wh]	[W]	[A]	[kg/h]	
	-6,7	54,4	35	46,1	739,2	2524	636,1	1,98	6,77	1,71	372,9	2,43	16,13	ASHRAE MBP
	[°F]	20	130	95	115									
	-10	55	32	55	567,0	1936	487,9	1,65	5,63	1,42	343,9	2,34	13,71	cecmaf MBP
	[°F]	14	131	89,6	131									
	-10	45	20	45	657,3	2245	565,7	2,00	6,82	1,72	329,3	2,29	15,39	EN12900 MBP
	[°F]	14	113	68	113									
	-6,7	48,9	18,3	48,9	711,2	2429	612,0	1,97	6,72	1,69	361,7	2,40	17,57	ARI540 MBP
	[°F]	20	120	65	120									
	-10	45	32	45	681,9	2329	586,9	2,07	7,07	1,78	329,3	2,29	14,92	opt
	[°F]	14	113	89,6	113									
	-25	45	32	45	312,2	1066	268,7	1,38	4,72	1,19	225,7	2,02	6,76	opt
	[°F]	-13	113	89,6	113									

Performance tables

R134a, 220V/50Hz, RSIR, fan 3m/s, VDE

	pe	Cooling capacity			COP	EER	P1	I	m		
	[°C]	[°F]	[W]	[Btu/h]	[kcal/h]	[W/W]	[Btu/Wh]	[kcal/Wh]	[W]	[A]	[kg/h]
[°C / °F]	-35	-31	197,3	674	169,8	1,12	3,82	0,96	176,4	1,97	4,26
cond. pressure	-25	-13	312,2	1066	268,7	1,38	4,72	1,19	225,7	2,02	6,76
pc= 45/113	-15	5	532,3	1818	458,1	1,82	6,23	1,57	291,9	2,18	11,60
return gas temp.	-10	14	681,9	2329	586,9	2,07	7,07	1,78	329,3	2,29	14,92
RGT= 32/90	0	32	1060,1	3620	912,3	2,60	8,87	2,23	408,2	2,56	23,44
liquid temp	5	41	1288,6	4401	1109,0	2,88	9,82	2,48	448,0	2,70	28,69
Tliq= 45/113	10	50	1543,6	5272	1328,4	3,17	10,82	2,73	487,0	2,85	34,64
[°C / °F]	-35	-31	198,1	677	170,5	1,12	3,81	0,96	177,6	1,98	4,71
cond. pressure	-25	-13	265,4	906	228,4	1,16	3,97	1,00	228,5	2,03	6,35
pc= 55/131	-15	5	439,7	1502	378,4	1,46	4,98	1,26	301,4	2,21	10,58
return gas temp	-10	14	567,0	1936	487,9	1,65	5,63	1,42	343,9	2,34	13,71
RGT= 32/90	0	32	901,8	3080	776,1	2,06	7,05	1,78	436,9	2,66	22,06
liquid temp	5	41	1109,3	3788	954,7	2,28	7,80	1,97	485,6	2,84	27,33
Tliq= 55/131	10	50	1343,6	4589	1156,3	2,51	8,58	2,16	534,7	3,04	33,40

Model

Designation **NLE12.6MF.2 220-240V/50Hz** Conf. 3 Sales code: **105G6389**

Configuration

Motorconfiguration RSCR
 Power supply (nominal) 220-240V/50Hz 1~
 Refrigerant R134a
 Application LBP+MBP
 Voltage range 198-254V
 Starting torque LST
 Approvals VDE

Electrical accessories / wiring diagram

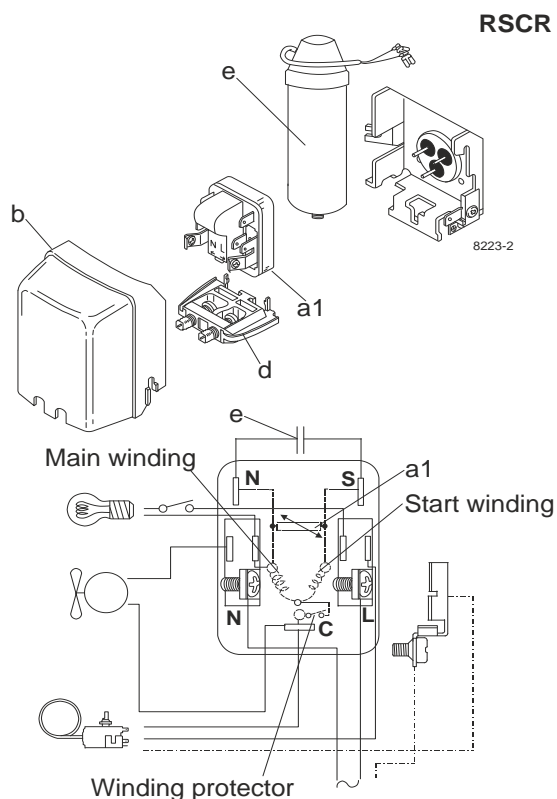

Ambient temperatures / system cooling

Ambient temperature min.: 10°C / 50°F
 Ambient temperature max.: 43°C / 110°F

System cooling (n/a: outside limits)			
T ambient	LBP	MBP	HBP
32°C / 90°F	fan 3m/s	fan 3m/s	n/a
38°C / 100°F	fan 3m/s	fan 3m/s	n/a
43°C / 110°F	fan 3m/s	fan 3m/s	n/a

Operation pressure range

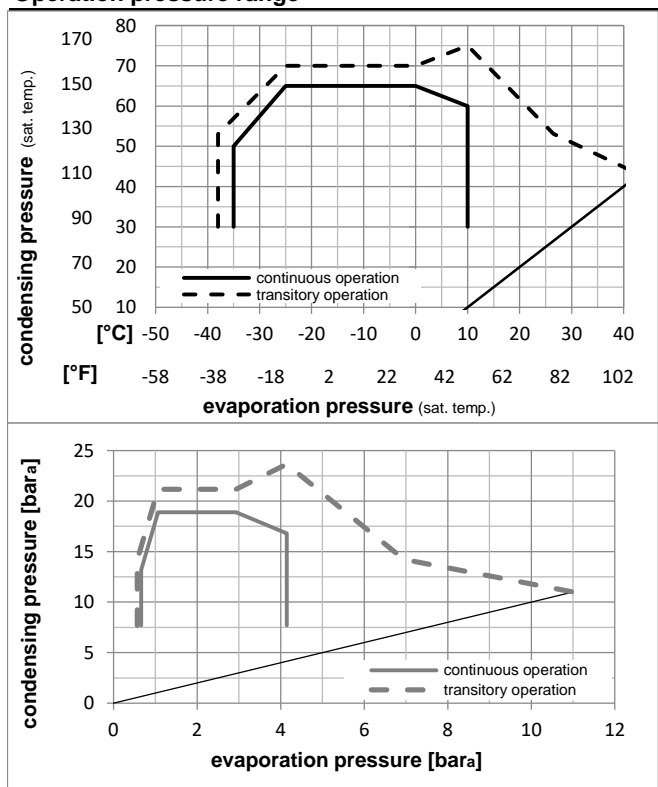

Components

- a1 e-PTC starter (220V, 25Ohm, 4.8mm) 103N0050
- e run capacitor (4μF, 4.8mm) 117-7119
- b plastic cover 103N2010
- d cord relief 103N1010
- bracket for run capacitor 117-0300
- screw M4x8mm 117-0301

Alternative components

- b plastic cover 103N2011

Model

Designation **NLE12.6MF.2 220-240V/50Hz** Conf. 3 Sales code: **105G6389**

Optimization + standard conditions

R134a, 220V/50Hz, RSCR, fan 3m/s, VDE

	Evaporating pressure (saturation temperature)				Condensing pressure (saturation temperature)						Power consumption			ASHRAE MBP				
	pe	pc	RGT	Tliq	Cooling capacity			COP	EER	P1	I	Ref. mass flow						
	[°C]	[°F]	[°C]	[°F]	[W]	[Btu/h]	[kcal/h]	[W/W]	[Btu/Wh]	[kcal/Wh]	[W]	[A]	[kg/h]					
	-6,66	20	54,4	130	35	95	46,1	115	750,7	2564	646,1	2,07	7,07	1,78	362,5	2,36	16,38	ASHRAE MBP
	-10	14	55	131	32	89,6	55	131	575,8	1967	495,6	1,72	5,88	1,48	334,4	2,27	13,92	cecomaf MBP
	-10	14	45	113	20	68	45	113	667,6	2280	574,5	2,09	7,12	1,79	320,1	2,23	15,63	EN12900 MBP
	-6,66	20	48,9	120	18,3	65	48,9	120	722,3	2467	621,6	2,05	7,01	1,77	351,6	2,33	17,84	ARI540 MBP
	-10	14	45	113	32	89,6	45	113	692,6	2365	596,1	2,16	7,39	1,86	320,1	2,23	15,16	opt
	-25	-13	45	113	32	89,6	45	113	317,1	1083	272,9	1,45	4,94	1,24	219,4	1,97	6,87	opt

Performance tables

R134a, 220V/50Hz, RSCR, fan 3m/s, VDE

	pe	Cooling capacity			COP	EER	P1	I	m		
	[°C]	[°F]	[W]	[Btu/h]	[kcal/h]	[W/W]	[Btu/Wh]	[kcal/Wh]	[W]	[A]	[kg/h]
[°C / °F]	-35	-31	200,4	684	172,5	1,17	3,99	1,01	171,6	1,91	4,32
cond. pressure	-25	-13	317,1	1083	272,9	1,45	4,94	1,24	219,4	1,97	6,87
pc= 45/113	-15	5	540,7	1847	465,3	1,91	6,51	1,64	283,8	2,12	11,79
return gas temp.	-10	14	692,6	2365	596,1	2,16	7,39	1,86	320,1	2,23	15,16
RGT= 32/90	0	32	1076,7	3677	926,6	2,71	9,26	2,33	396,9	2,48	23,81
liquid temp	5	41	1308,8	4470	1126,4	3,00	10,26	2,59	435,6	2,63	29,14
Tliq= 45/113	10	50	1567,7	5354	1349,2	3,31	11,31	2,85	473,5	2,77	35,18
[°C / °F]	-35	-31	201,2	687	173,1	1,17	3,98	1,00	172,6	1,93	4,79
cond. pressure	-25	-13	269,5	921	232,0	1,21	4,14	1,04	222,2	1,97	6,45
pc= 55/131	-15	5	446,6	1525	384,3	1,52	5,20	1,31	293,0	2,15	10,75
return gas temp	-10	14	575,8	1967	495,6	1,72	5,88	1,48	334,4	2,27	13,92
RGT= 32/90	0	32	915,9	3128	788,2	2,16	7,36	1,86	424,8	2,58	22,40
liquid temp	5	41	1126,6	3848	969,6	2,39	8,15	2,05	472,1	2,76	27,76
Tliq= 55/131	10	50	1364,6	4660	1174,4	2,62	8,96	2,26	519,9	2,95	33,92

Model

Designation **NLE12.6MF.2 220-240V/60Hz** Conf. 4 Sales code: **105G6389**

Configuration

Motorconfiguration CSIR
 Power supply (nominal) 220-240V/60Hz 1~
 Refrigerant R134a
 Application LBP
 Voltage range 198-254V
 Starting torque HST
 Approvals VDE

Electrical accessories / wiring diagram

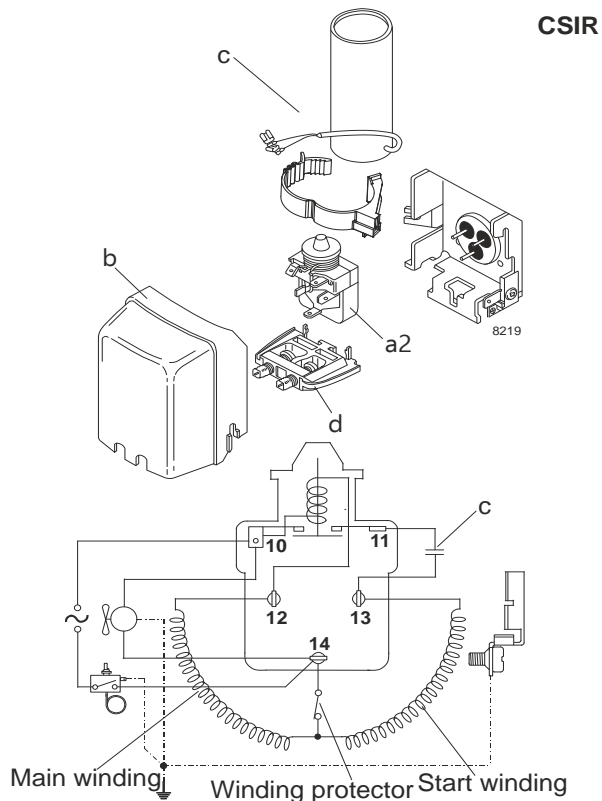

Ambient temperatures / system cooling

Ambient temperature min.: 10°C / 50°F
 Ambient temperature max.: 43°C / 110°F

System cooling (n/a: outside limits)			
T ambient	LBP	MBP	HBP
32°C / 90°F	fan 3m/s	n/a	n/a
38°C / 100°F	fan 3m/s	n/a	n/a
43°C / 110°F	fan 3m/s	n/a	n/a

Operation pressure range

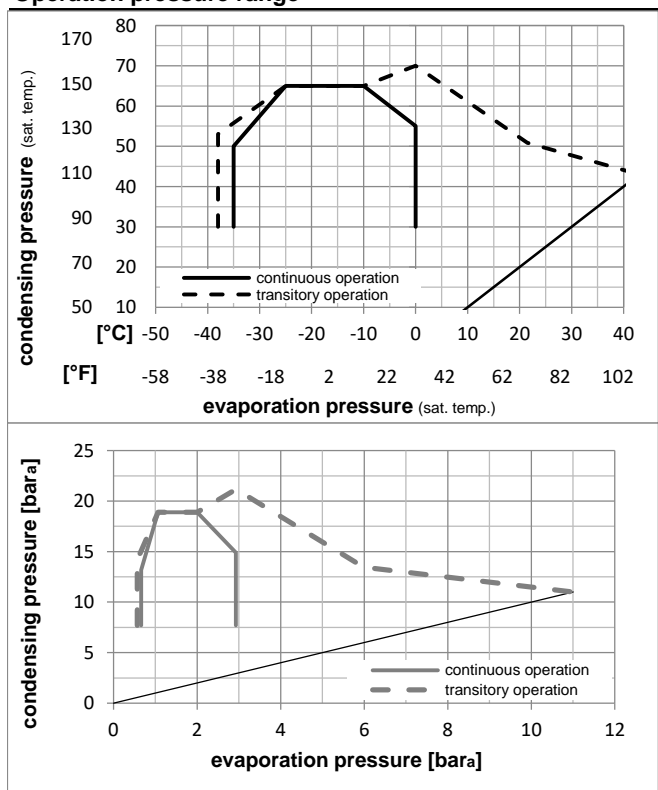

Components

- a2 relay 117U6005
- c start capacitor (80µF) 117U5015
- b plastic cover 103N2010
- d cord relief 103N1010

Alternative components

- b plastic cover 103N2011

Model

Designation **NLE12.6MF.2 220-240V/60Hz** Conf. 4 Sales code: **105G6389**

Optimization + standard conditions

R134a, 220V/60Hz, CSIR, fan 3m/s, VDE

	Evaporating pressure (saturation temperature)				Condensing pressure (saturation temperature)			Return gas temp.			Liquid temp.			Cooling capacity			COP	EER	Power consumption			ASHRAE MBP
	pe	pc	RGT	Tliq	[W]	[Btu/h]	[kcal/h]	[W/W]	[Btu/Wh]	[kcal/Wh]	P1	I	m	[W]	[A]	[kg/h]						
[°C]	-6,66	54,4	35	46,1	890,5	3041	766,4	2,00	6,84	1,72	444,8	2,90	19,43									
[°F]	20	130	95	115																		
[°C]	-10	55	32	55	683,0	2333	587,8	1,66	5,69	1,43	410,3	2,79	16,52								cecomaf MBP	
[°F]	14	131	89,6	131																		
[°C]	-10	45	20	45	791,9	2704	681,5	2,02	6,88	1,73	392,8	2,73	18,54								EN12900 MBP	
[°F]	14	113	68	113																		
[°C]	-6,66	48,9	18,3	48,9	856,8	2926	737,3	1,99	6,78	1,71	431,5	2,86	21,16								ARI540 MBP	
[°F]	20	120	65	120																		
[°C]	-10	45	32	45	821,5	2806	707,0	2,09	7,14	1,80	392,8	2,73	17,98								opt	
[°F]	14	113	89,6	113																		
[°C]	-25	45	32	45	376,1	1284	323,7	1,40	4,77	1,20	269,2	2,41	8,15								opt	
[°F]	-13	113	89,6	113																		

Performance tables

R134a, 220V/60Hz, CSIR, fan 3m/s, VDE

	pe	Cooling capacity			COP	EER	P1	I	m		
	[°C]	[°F]	[W]	[Btu/h]	[kcal/h]	[W/W]	[Btu/Wh]	[kcal/Wh]	[W]	[A]	[kg/h]
[°C / °F]	-35	-31	237,7	812	204,6	1,13	3,86	0,97	210,5	2,35	5,13
cond. pressure	-30	-22	291,0	994	250,5	1,23	4,20	1,06	236,8	2,36	6,29
pc= 45/113	-25	-13	376,1	1284	323,7	1,40	4,77	1,20	269,2	2,41	8,15
return gas temp.	-23,3	-10	412,2	1408	354,8	1,46	5,00	1,26	281,5	2,44	8,94
RGT= 32/90	-15	5	641,3	2190	551,9	1,84	6,29	1,58	348,3	2,60	13,98
liquid temp	-5	23	1033,5	3529	889,4	2,35	8,03	2,02	439,4	2,88	22,73
Tliq= 45/113	0	32	1277,1	4362	1099,1	2,62	8,96	2,26	487,0	3,05	28,24
[°C / °F]	-35	-31	238,7	815	205,4	1,13	3,85	0,97	211,8	2,37	5,68
cond. pressure	-30	-22	263,1	898	226,4	1,10	3,77	0,95	238,4	2,37	6,27
pc= 55/131	-25	-13	319,7	1092	275,2	1,17	4,01	1,01	272,6	2,42	7,64
return gas temp	-23,3	-10	346,3	1183	298,1	1,21	4,14	1,04	285,8	2,45	8,29
RGT= 32/90	-15	5	529,7	1809	455,9	1,47	5,03	1,27	359,5	2,63	12,75
liquid temp	-5	23	868,6	2966	747,5	1,87	6,39	1,61	464,5	2,97	21,11
Tliq= 55/131	0	32	1086,4	3710	934,9	2,08	7,12	1,79	521,2	3,17	26,57

Model

Designation **NLE12.6MF.2 220-240V/60Hz** Conf. 5 Sales code: **105G6389**

Configuration

Motorconfiguration RSCR
 Power supply (nominal) 220-240V/60Hz 1~
 Refrigerant R134a
 Application LBP
 Voltage range 198-254V
 Starting torque LST
 Approvals VDE

Electrical accessories / wiring diagram

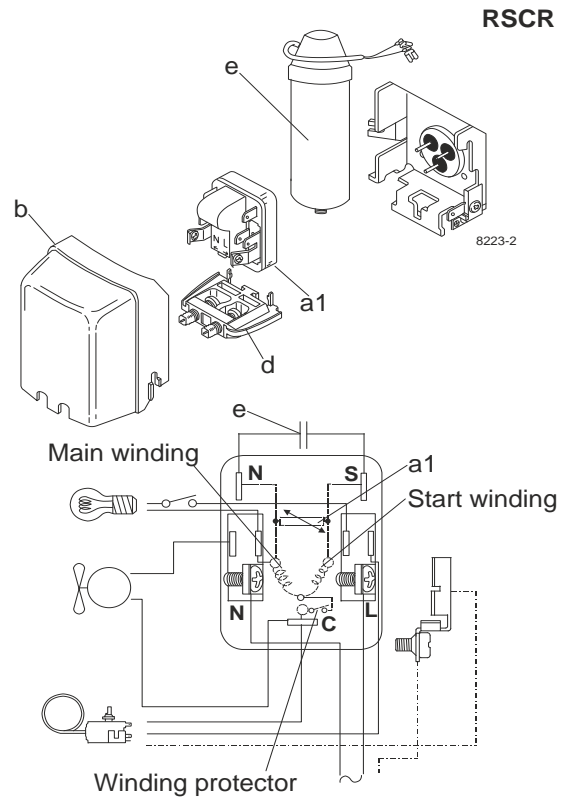

Ambient temperatures / system cooling

Ambient temperature min.: 10°C / 50°F
 Ambient temperature max.: 43°C / 110°F

System cooling (n/a: outside limits)			
T ambient	LBP	MBP	HBP
32°C / 90°F	fan 3m/s	n/a	n/a
38°C / 100°F	fan 3m/s	n/a	n/a
43°C / 110°F	fan 3m/s	n/a	n/a

Operation pressure range

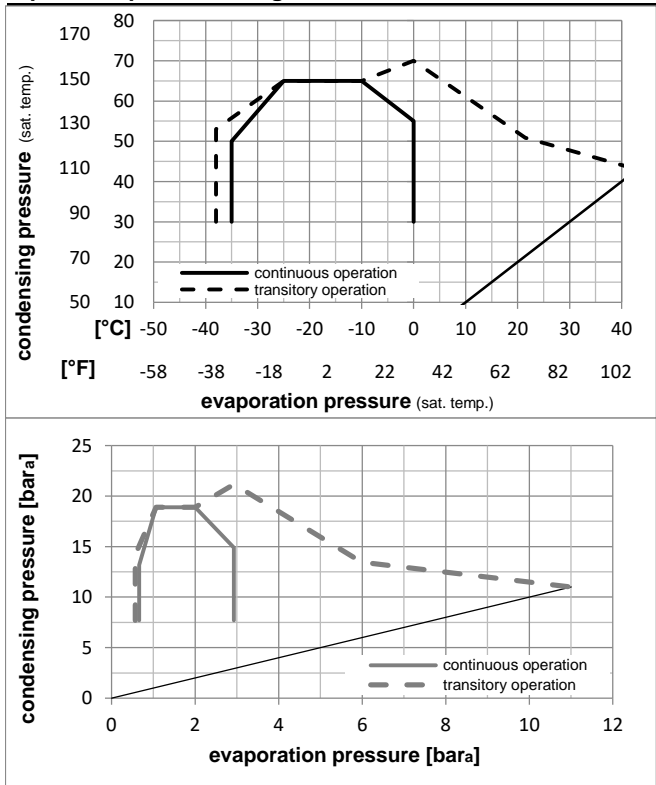

Components

- a1 e-PTC starter (220V, 25Ohm, 4.8mm) 103N0050
- e run capacitor (4μF, 4.8mm) 117-7119
- b plastic cover 103N2010
- d cord relief 103N1010
- bracket for run capacitor 117-0300
- screw M4x8mm 117-0301

Alternative components

- b plastic cover 103N2011

Model

Designation **NLE12.6MF.2 220-240V/60Hz** Conf. 5 Sales code: **105G6389**

Optimization + standard conditions

R134a, 220V/60Hz, RSCR, fan 3m/s, VDE

Evaporating pressure (saturation temperature)														
Condensing pressure (saturation temperature)														
Return gas temp.														
Liquid temp.														
Cooling capacity														
COP														
EER														
Power consumption														
Current consumption														
Ref. mass flow														
	pe	pc	RGT	Tliq	[W]	[Btu/h]	[kcal/h]	[W/W]	[Btu/Wh]	[kcal/Wh]	P1	I	m	
[°C]	[°C]	[°C]	[°C]	[°C]	[W]	[Btu/h]	[kcal/h]	[W/W]	[Btu/Wh]	[kcal/Wh]	[W]	[A]	[kg/h]	
[°C]	-6,66	54,4	35	46,1	904,4	3089	778,4	2,09	7,14	1,80	432,5	2,82	19,73	ASHRAE MBP
[°F]	20	130	95	115										
[°C]	-10	55	32	55	693,7	2369	597,0	1,74	5,94	1,50	398,9	2,71	16,77	cecomaf MBP
[°F]	14	131	89,6	131										
[°C]	-10	45	20	45	804,3	2747	692,2	2,11	7,19	1,81	381,9	2,66	18,83	EN12900 MBP
[°F]	14	113	68	113										
[°C]	-6,66	48,9	18,3	48,9	870,2	2972	748,9	2,07	7,08	1,79	419,5	2,78	21,49	ARI540 MBP
[°F]	20	120	65	120										
[°C]	-10	45	32	45	834,4	2850	718,1	2,18	7,46	1,88	381,9	2,66	18,26	opt
[°F]	14	113	89,6	113										
[°C]	-25	45	32	45	382,0	1305	328,7	1,46	4,98	1,26	261,8	2,35	8,28	opt
[°F]	-13	113	89,6	113										

Performance tables

R134a, 220V/60Hz, RSCR, fan 3m/s, VDE

	pe	Cooling capacity			COP	EER	P1	I	m			
		[°C]	[°F]	[W]						[Btu/h]	[kcal/h]	[W/W]
[°C / °F]	-35	-31		241,4	825	207,8	1,18	4,03	1,02	204,7	2,28	5,21
cond. pressure	-30	-22		295,6	1010	254,4	1,28	4,38	1,10	230,3	2,30	6,39
pc= 45/113	-25	-13		382,0	1305	328,7	1,46	4,98	1,26	261,8	2,35	8,28
return gas temp.	-23,3	-10		418,7	1430	360,3	1,53	5,23	1,32	273,6	2,37	9,08
RGT= 32/90	-15	5		651,4	2225	560,6	1,92	6,57	1,66	338,6	2,53	14,20
liquid temp	-5	23		1049,6	3585	903,3	2,46	8,39	2,11	427,2	2,80	23,08
Tliq= 45/113	0	32		1297,1	4430	1116,3	2,74	9,36	2,36	473,5	2,96	28,68
[°C / °F]	-35	-31		242,4	828	208,6	1,18	4,02	1,01	206,0	2,30	5,77
cond. pressure	-30	-22		267,2	913	230,0	1,15	3,94	0,99	231,8	2,31	6,37
pc= 55/131	-25	-13		324,7	1109	279,5	1,23	4,18	1,05	265,0	2,36	7,76
return gas temp	-23,3	-10		351,8	1201	302,7	1,27	4,32	1,09	277,8	2,38	8,42
RGT= 32/90	-15	5		538,0	1837	463,0	1,54	5,26	1,32	349,6	2,56	12,95
liquid temp	-5	23		882,2	3013	759,2	1,95	6,67	1,68	451,6	2,88	21,44
Tliq= 55/131	0	32		1103,4	3768	949,6	2,18	7,44	1,87	506,8	3,08	26,99