

SC15/15G Universal Twin Compressor R134a 220-240V 50Hz

General

Code number	104G8580
Approvals	EN 60335-2-34
Compressors on pallet	18

Application

Application	LBP/HBP		
Frequency	Hz	50	60
Evaporating temperature	°C	-25 to 15	-
Voltage range	V	198 - 254	-
Max. condensing temperature continuous (short)	°C	60 (70)	-
Max. winding temperature continuous (short)	°C	125 (135)	-

Cooling requirements

Frequency	Hz	50			60		
Application		LBP	MBP	HBP	LBP	MBP	HBP
32°C		F ₂	F ₂	F ₂	-	-	-
38°C		F ₂	F ₂	F ₂	-	-	-
43°C		F ₂	F ₂	F ₂	-	-	-
Remarks on application:							

Motor

Motor type	CSIR		
LRA (rated after 4 sec. UL984) *, HST LST	A	2 x 14.8	-
Cut in Current *, HST LST	A	2 x 14.8	-
Resistance, main start winding (25°C)	Ω	5.0	13.7

* Operational current for the second compressor time-delayed.

Design

Displacement	cm ³	2 x 15.28
Oil quantity (type)	cm ³	1120 (polyolester)
Maximum refrigerant charge	g	2200
Free gas volume in compressor	cm ³	2820
Weight without electrical equipment	kg	28.0

Dimensions

Height	mm	A	249
		B	244
		B1	183
		B2	100
Suction connector (service valve)	location/I.D. mm	C	12 37°
Suction connector (solder connector)	location/I.D. mm	C	12 37°
Process connector	location/I.D. mm angle	D	6.2 37°
	material comment		Copper Rubber plug
Discharge connector	location/I.D. mm angle	E	6.2 37°
	material comment		Copper Rubber plug
Oil cooler connector	location/I.D. mm angle	F	-
	material comment		-
Connector tolerance	I.D. mm		±0.09
Remarks:			

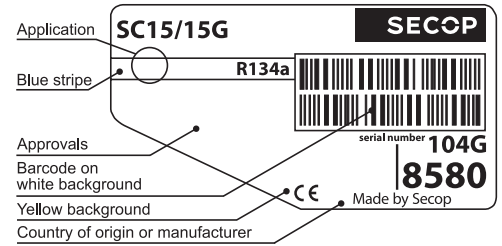

- S = Static cooling normally sufficient
- O = Oil cooling
- F₁ = Fan cooling 1.5 m/s (compressor compartment temperature equal to ambient temperature)
- F₂ = Fan cooling 3.0 m/s necessary
- SG = Suction gas cooling normally sufficient
- = not applicable in this area

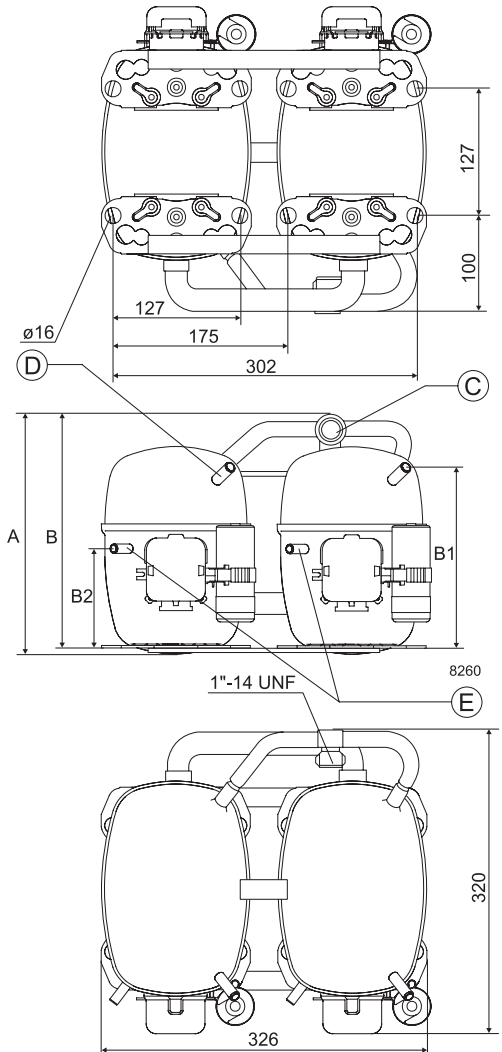

EN 12900 Household (CECOMAF) 220V, 50Hz, fan cooling F₂

Evap. temp. in °C	-45	-40	-35	-30	-25	-23.3	-20	-15	-10	-6.7	-5	0	5	7.2	10	15	20
Capacity in W					328	413	581	847	1137	1344	1457	1815	2220	2415	2679	3201	
Power cons. in W					465	517	614	752	879	957	995	1099	1190	1226	1269	1335	
Current cons. in A					4.43	4.55	4.79	5.17	5.57	5.84	5.98	6.40	6.84	7.03	7.29	7.75	
COP in W/W					0.71	0.80	0.95	1.13	1.29	1.40	1.46	1.65	1.87	1.97	2.11	2.40	

ASHRAE LBP 220V, 50Hz, fan cooling F₂

Evap. temp. in °C	-45	-40	-35	-30	-25	-23.3	-20	-15	-10	-6.7	-5	0	5	7.2	10	15	20
Capacity in W					405	510	717	1047	1405	1662	1803	2249	2754	2998	3330	3986	
Power cons. in W					465	517	614	752	879	957	995	1099	1190	1226	1269	1335	
Current cons. in A					4.43	4.55	4.79	5.17	5.57	5.84	5.98	6.40	6.84	7.03	7.29	7.75	
COP in W/W					0.87	0.99	1.17	1.39	1.60	1.74	1.81	2.05	2.31	2.44	2.62	2.99	

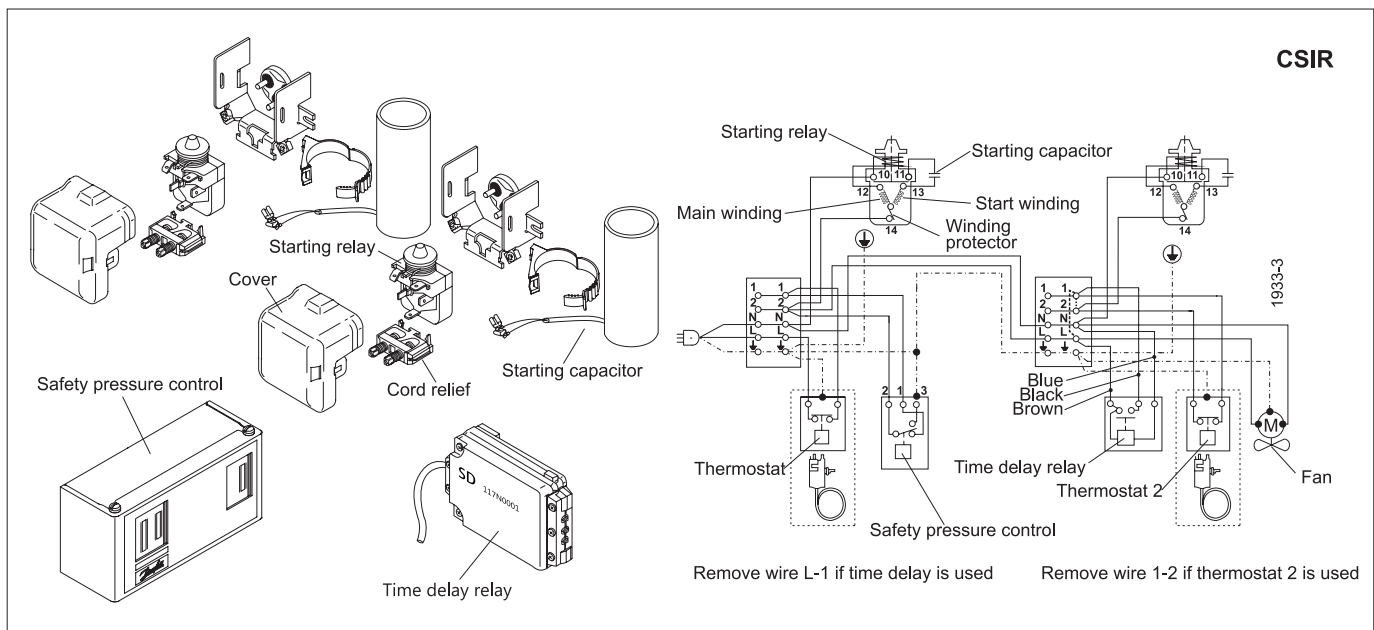

Accessories	SC15/15G	pcs.	Code number
Starting device	470 mm cable length		-
	550 mm cable length	2	-
	650 mm cable length		-
Starting relay	6.3 mm spade connectors	2	117U6005
Start. capacitor 80 µF	6.3 mm spade connectors	2	117U5017
Cover		2	103N2009
Cord relief		2	103N1004
Time-delay relay		1	117N0001
Check valve (to be used with time-delay relay)		2	020-1014
Service valve	12 mm	1	118-7350
Solder connector (alternative)	12 mm	1	104B0584
Service valve	16 mm	1	-
Solder connector (alternative)	16 mm	1	-
Seal ring for service valve and solder connector		1	118-3638

Test conditions	EN 12900/CECOMAF	ASHRAE LBP
Condensing temperature	55°C	55°C
Ambient temperature	32°C	32°C
Suction gas temperature	32°C	32°C
Liquid temperature	55°C	32°C

Mounting accessories		pcs.	Code number
Bolt joint for one compressor	Ø: 16 mm	2	118-1917
Bolt joint in quantities	Ø: 16 mm	2	118-1918

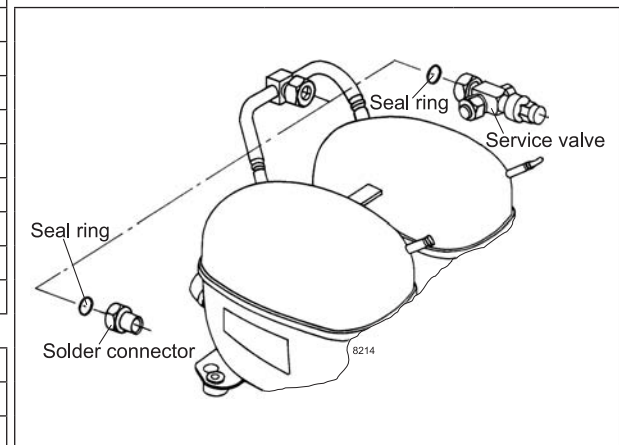

Nidec GA Compressors accepts no responsibility for possible errors in catalogs, brochures, and other printed material. Nidec GA Compressors reserves the right to alter its products without notice. This also applies to products already on order provided that such alterations can be made without consequential changes being necessary to specifications already agreed. All trademarks in this material are the property of the respective companies. Secop and the Secop logotype are trademarks of Nidec Global Appliance Germany GmbH. All rights reserved. www.secop.com